

GB
 08

**OFICJALNY PRZEDSTAWICIEL w
POLSCE : RAIS-TOOLS**

**BUSZEWO 22
62-045 PNIEWY
POLSKA**

**TEL. +48 61 822 90 52
TEL. +48 698 684 211**

**www.rais.pl
biuro@rais.pl**

KOPAL®





MODULAR VICES

Presentation	02 - 03
Standard Vices	
22 kN with serrated jaws	04
22 kN with rectified jaws	05
10 kN with rectified jaws	08
Double vice	
22 kN with rectified jaws	06
Standard Vice with fast clamping	
12 kN with rectified jaws	07
Divided Vices	
22 kN with serrated jaws	09
22 kN with rectified jaws	10
Divided Vice with fast clamping	
12 kN with rectified jaws	11
Fixing - Locators	12
Modular parts	18

KOPAL



VERTICAL CLAMPING

KOPAL System	
Principle - Presentation	40
Boxed sets	41
Electro-erosion Clamping	42
Piccolo 6500 N	43
Monobloc 16000 N	44 - 45
Bloc bride 16000 N	46 - 47
Duo 11000 N	48 - 49
Clamping accessories	50 - 51
Big block 40000 N	52 - 54
Spare parts	55
Chain Clamping	
16000 N	56 - 57
50000 N	58
Workpiece Support	59
Other clamping	
Terrific 11000 N	60 - 61
Maxibloc 35000 N	62 - 63
Blocapress 50000 N	64
Fixing, T-nuts, screws	65



HORIZONTAL CLAMPING

Presentation	14 - 15
22000 N. - 12000 N.	
Clamping equipments	16 - 17
Modular parts	18 - 24
Fixing - Locators	23
10000 N.	
Clamping equipments	26 - 27
Modular parts	28 - 33
Fixing - Locators	27
6500 N.	
Clamping equipments	34
Modular parts	34 - 35
4000 N. Mini-clamp	
Modular parts	36 - 37
Clamp-slot for table T-slot	38





REGULATORS FOR VICES

Power regulators FORCE	68 - 69
Interchangeable tips	69
Fixed jaws with V-guides	70

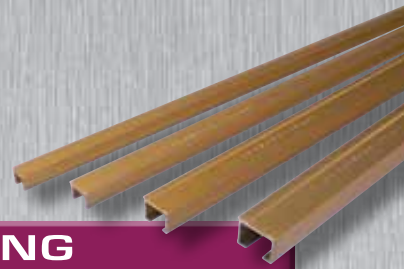

CLAMPING ACCESSORIES

Slot covers	72
Hole Covers	73
Stops for T-slots	74
Clip-on protectors	75
Fixture	76
T-nuts	77
Centring locators	77



CHAMFERING

Presentation	80
Inner devices	81
Inner devices Slim Line	82
Outer devices	83
Devices for Tubes (Inner and Outer)	84
Spare parts	85
Cutting blades	86 - 87



CHAMFERING MACHINE

Chamfering carrier Azimut	90
Contouring carrier	91
Cutters and components	92
Electric Motor RM 500 with flexible transmission	93
Machine for straight chamfer LM 300	94
Contouring machine CM 300	95



SAFETY

Chip Hooks	98
Pincers and Cutters for chips	99

KOPAL®





Modular Vices System KOPAL®

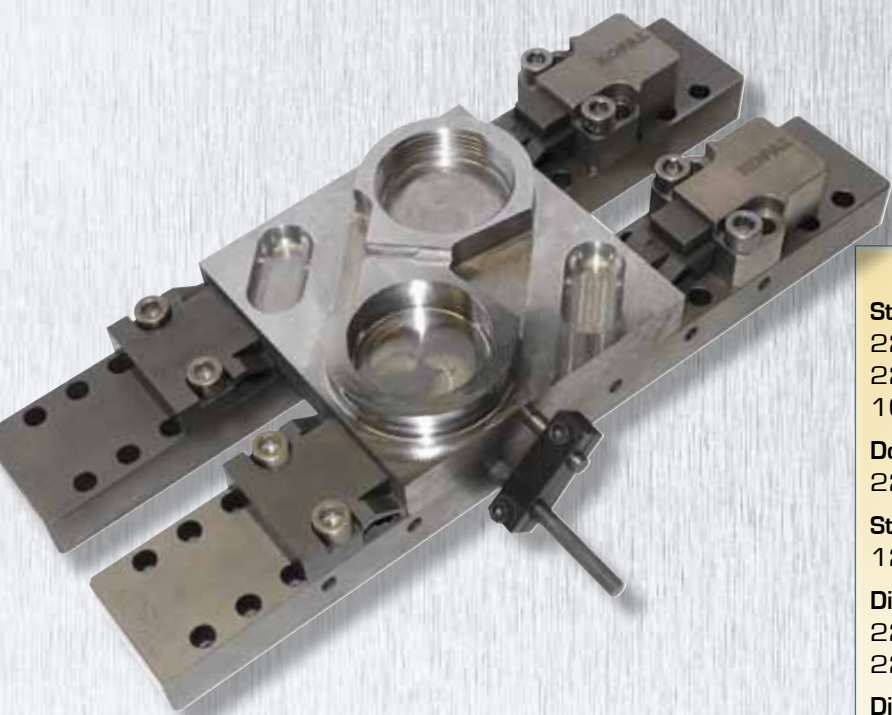

Presentation	02 - 03
Standard Vices	
22 kN with serrated jaws	04
22 kN with rectified jaws	05
10 kN with rectified jaws	08
Double vice	
22 kN with rectified jaws	06
Standard Vice with fast clamping	
12 kN with rectified jaws	07
Divided Vices	
22 kN with serrated jaws	09
22 kN with rectified jaws	10
Divided Vice with fast clamping	
12 kN with rectified jaws	11
Fixing - Locators	12
Modular parts	18

KOPAL®

KOPAL 01

MODULAR VICE

MODULAR VICE

Capacity : **280 mm**
Clamping force : **22000 N.**
Serrated jaws
with thrust screw
Ref. **09-005**



Page 04

Capacity : **280 mm**
Clamping force : **22000 N.**
Rectified jaws
with thrust screw
Ref. **09-004**



Page 05

Capacity : **2 x 106 mm**
Clamping force : **22000 N.**
Rectified jaws
with thrust screw
Ref. **09-002**

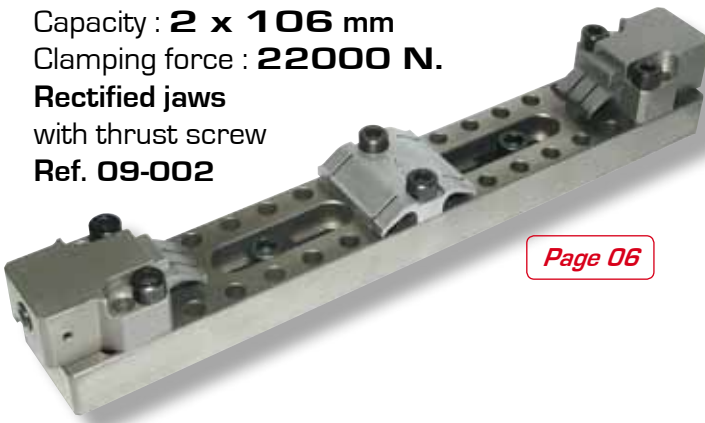

Page 06

Capacity : **280 mm**
Clamping force : **12000 N.**
Rectified jaws
with clamping eccentric
Ref. **09-010**



Page 07

Capacity : **232 mm**
Clamping force : **10000 N.**
Rectified jaws
with thrust screw
Ref. **09-455**

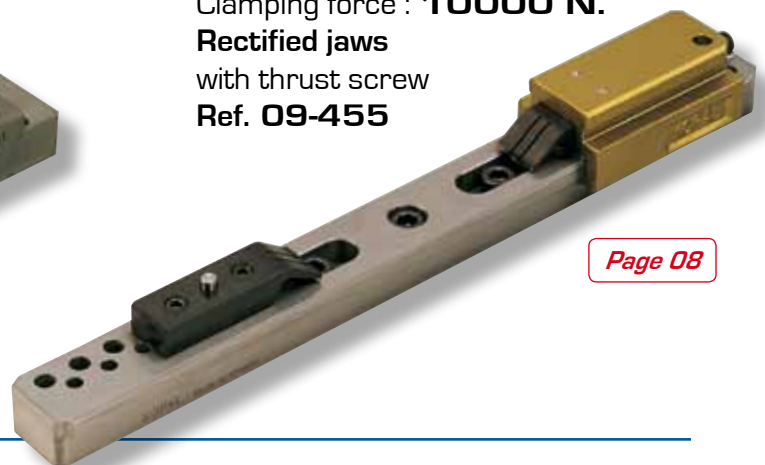

Page 08

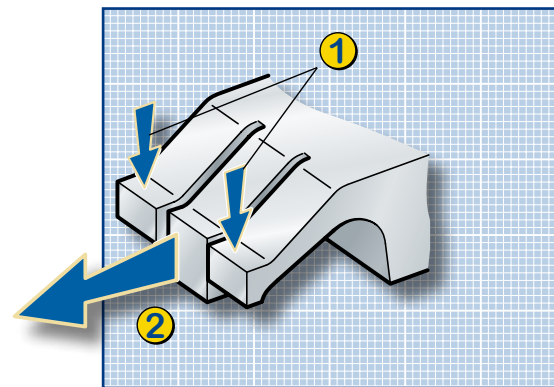

MODULAR VICE

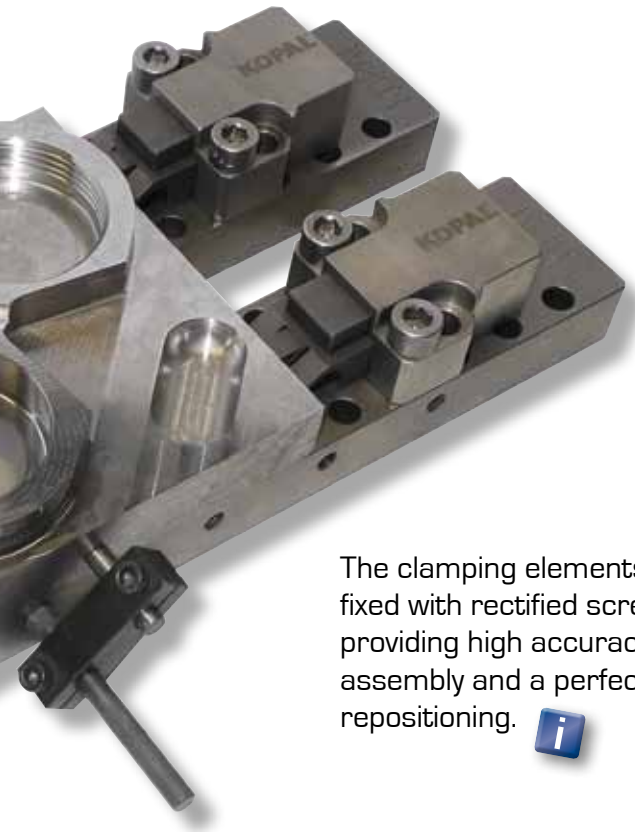

The clamping elements are fixed with rectified screws providing high accuracy of assembly and a perfect repositioning.



KOPAL

- High capacity Vice
- Compact system
- High clamping force
- Simple, quick and precise installation

Capacity : adapts to workpiece
Clamping force : **22000 N.**
Serrated jaws
with thrust screw
Ref. **09-011**

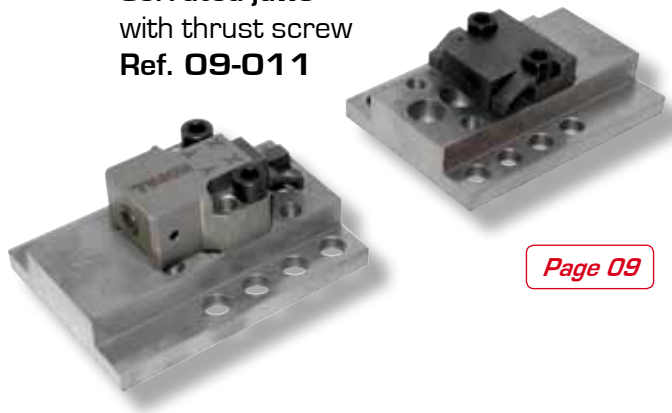

Page 09

Capacity : adapts to workpiece
Clamping force : **22000 N.**
Rectified jaws
with thrust screw
Ref. **09-006**



Page 10

The clamping action ensures the **PUSHING DOWN** and **CLAMPING** of the workpiece to be machined..

- 1 **PUSHING DOWN :**
the flexible parts clamp the workpiece, pressing it down until it makes contact with the rigid part.
- 2 **CLAMPING AND POSITIONING :**
the rigid part clamps and positions the workpiece in place.

Capacity : adapts to workpiece
Clamping force : **12000 N.**
Rectified jaws
with clamping eccentric
Ref. **09-014**

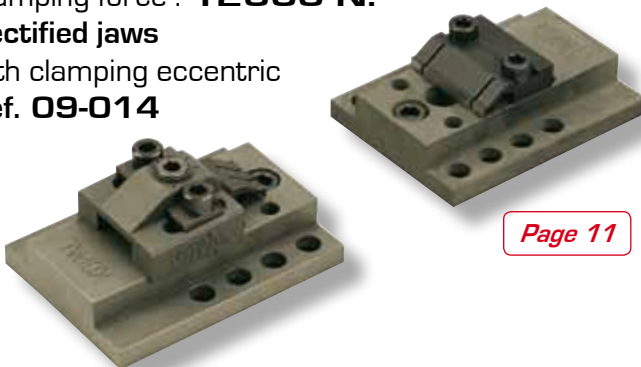

Page 11

Modular Parts

Page 18

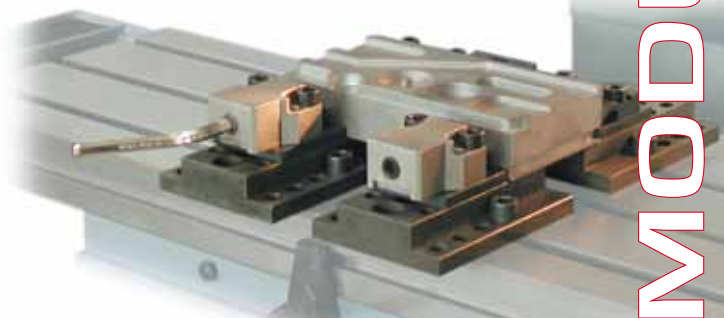

MODULAR VICE

22000 N.

Standard Vice

Ref.

Capacity : one workpiece **280 mm max.** **09-005**

Including :

- ① 1 base plate : 09-015
length 400 mm, height 28 mm
- ② 1 movable indexable jaw : 09-027
clamping range 16 mm
- ③ 1 fixed indexable jaw : 09-081
width 60 mm

*With M 12 clamping screws
and clamping key.*



Clamping force : **22000 N.**
Clamping torque : 50 N.m
Clamping range : **16 mm**
Positioning : 22 mm

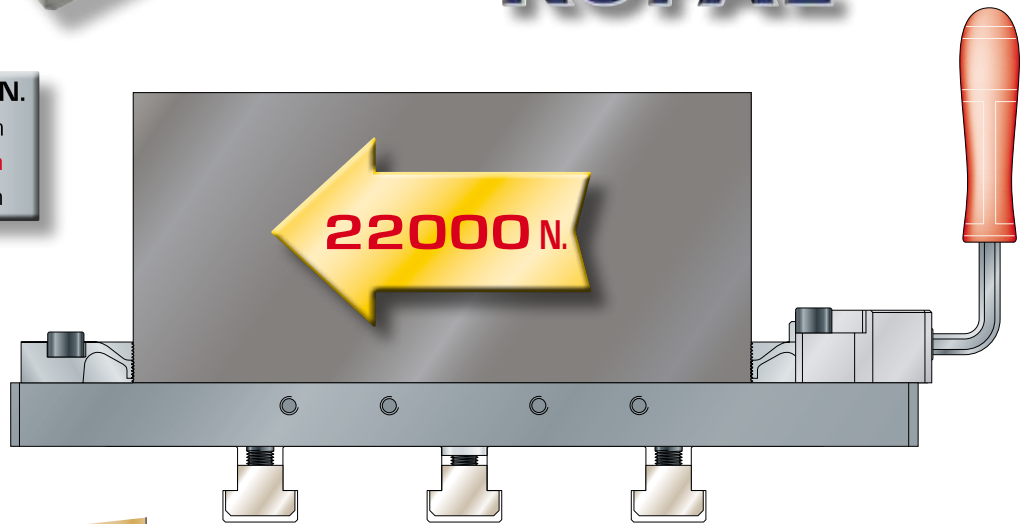

*used with 8 mm Riser blocks
(page 22)*

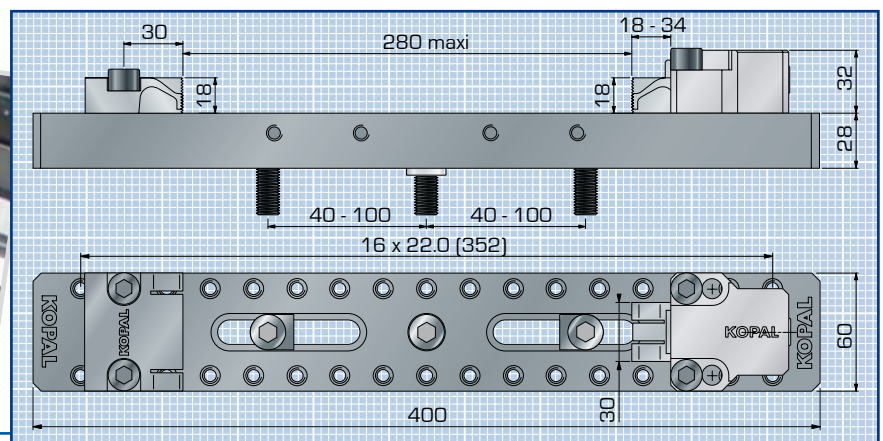
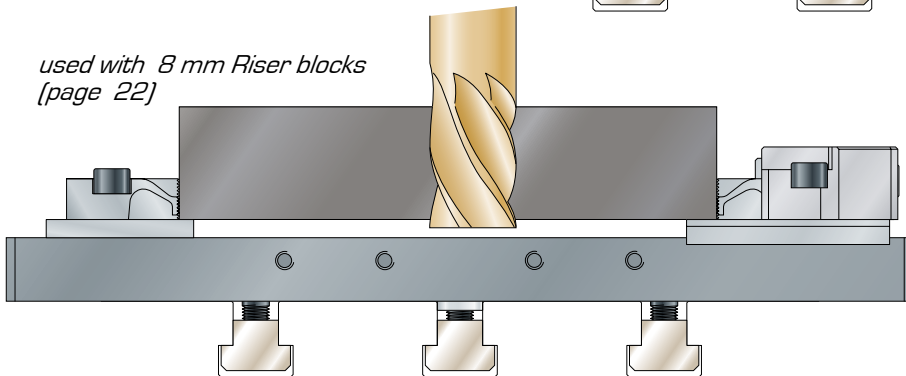

04 KOPAL

MODULAR VICE

Standard Vice

Ref.

09-004

Capacity : one workpiece **280 mm**

Including :

- ① 1 base plate : 09-015
length 400 mm, height 28 mm
- ② 1 movable indexable jaw : 09-025
clamping range 16 mm
- ③ 1 fixed indexable jaw : 09-080
width 60 mm

*with M 12 clamping screws
and clamping key.*

**Rectified
jaws** 



**Capacity
up to 280 mm**

Clamping force :	22000 N.
Clamping torque :	50 N.m
Clamping range :	16 mm
Positioning :	22 mm

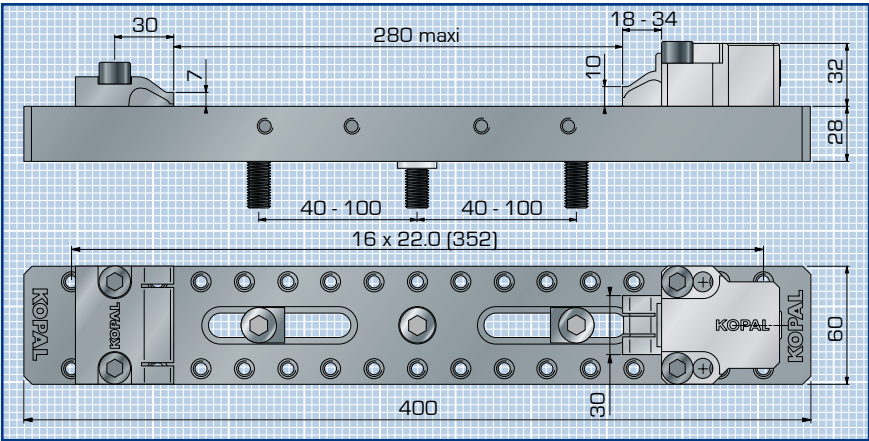
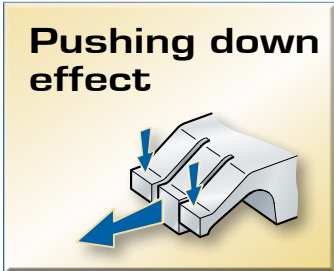
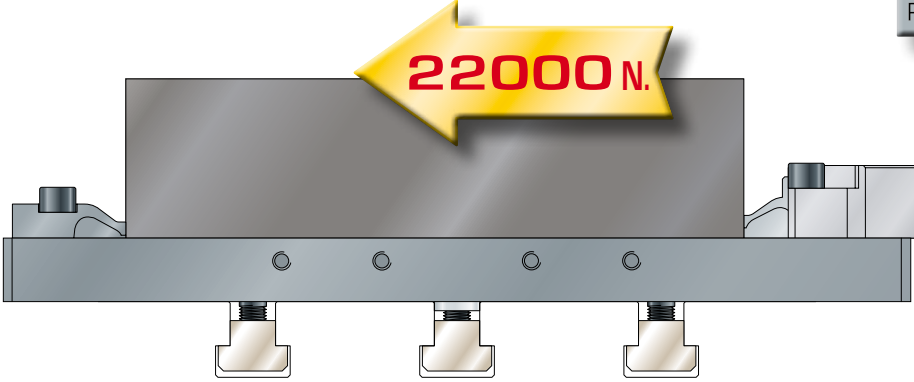

**Modular parts
page 18**

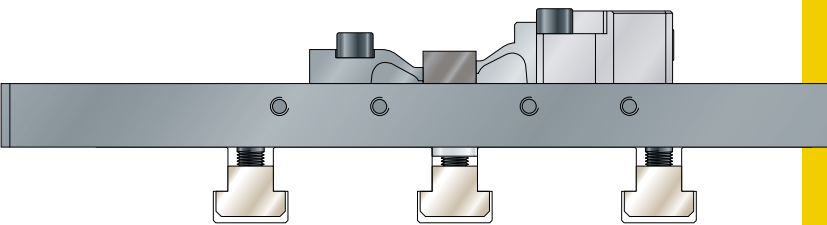

22000 N.

Double Vice

Ref.

Capacity : 2 workpieces **106 mm maxi** **09-002**

Including :

- ① 1 base plate : 09-015
length 400 mm, height 28 mm
- ② 2 movable indexable jaw : 09-025
clamping range 16 mm
- ③ 1 fixed indexable jaw : 09-082
width 60 mm

*with M 12 clamping screws
and clamping key.*

**● Double
your production**



**Rectified
jaws** 

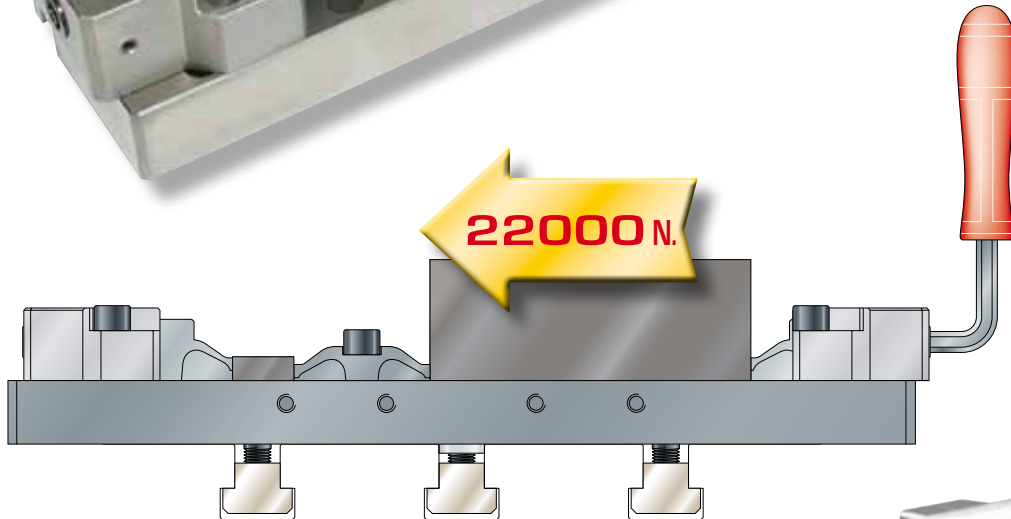

KOPAL

Clamping force :	22000 N.
Clamping torque :	50 N.m
Clamping range :	16 mm
Positioning :	22 mm

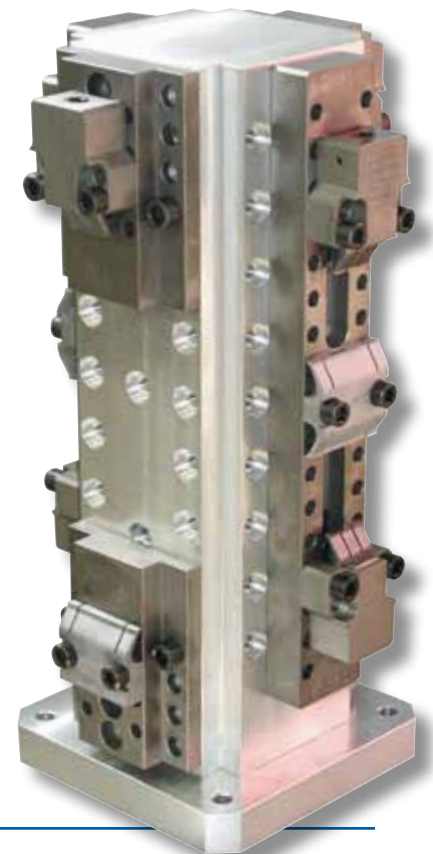
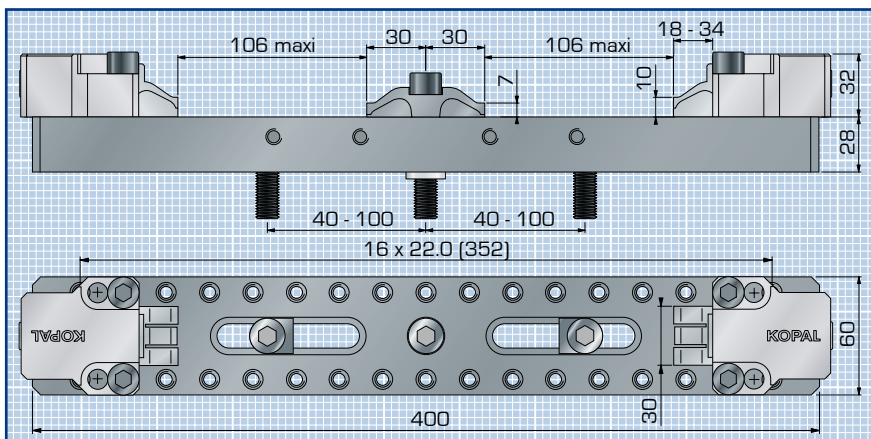

06 KOPAL

MODULAR VICE

Vice with fast clamping

Ref.

09-010

Capacity : one workpiece 280 mm maxi

Including :

- ① 1 base plate : 09-015
length 400 mm, height 28 mm
- ② 1 movable indexable jaw : 09-020
clamping range 1.2 mm
- ③ 1 fixed indexable jaw : 09-080
width 60 mm

*With M 12 clamping screws
and clamping key.*

Rectified jaws

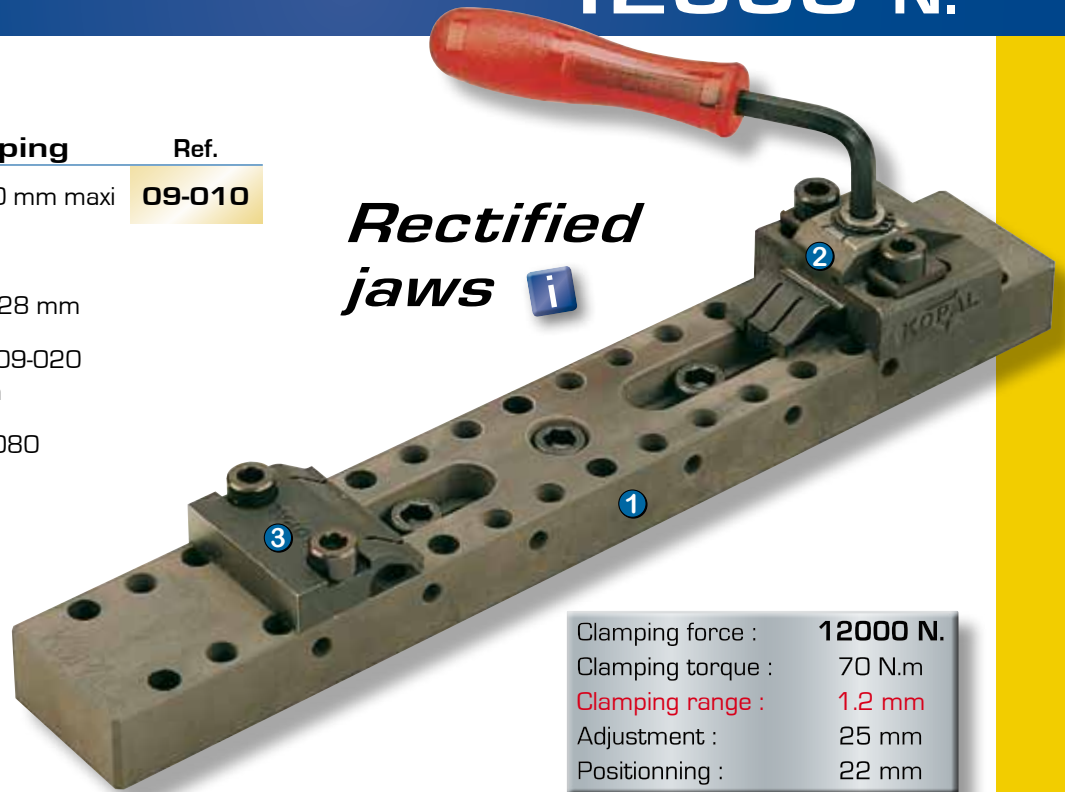

Clamping force :	12000 N.
Clamping torque :	70 N.m
Clamping range :	1.2 mm
Adjustment :	25 mm
Positioning :	22 mm

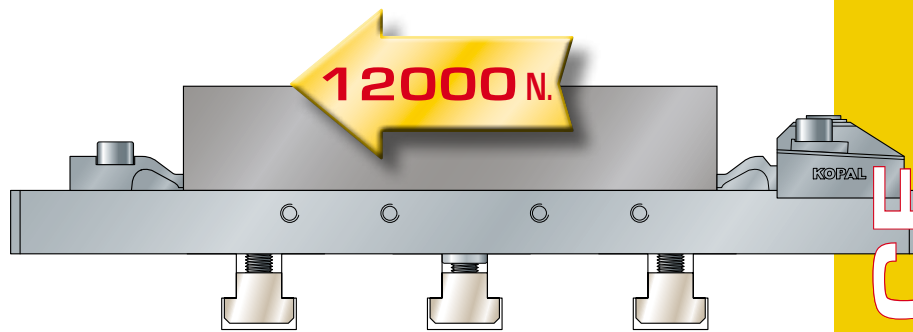
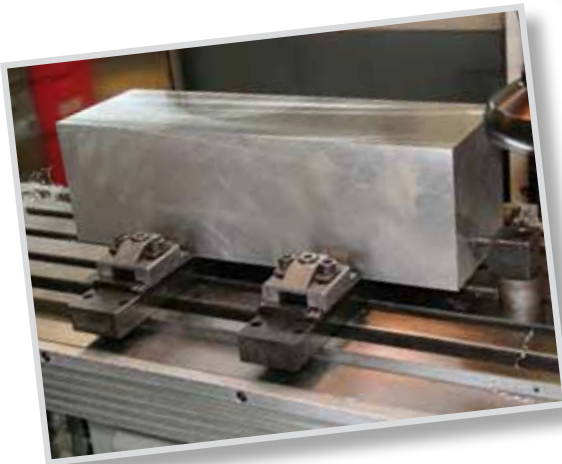

**Fast clamping
1/4 turn**

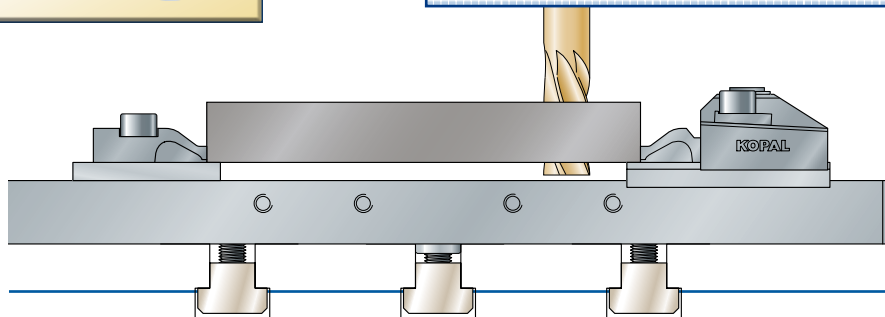
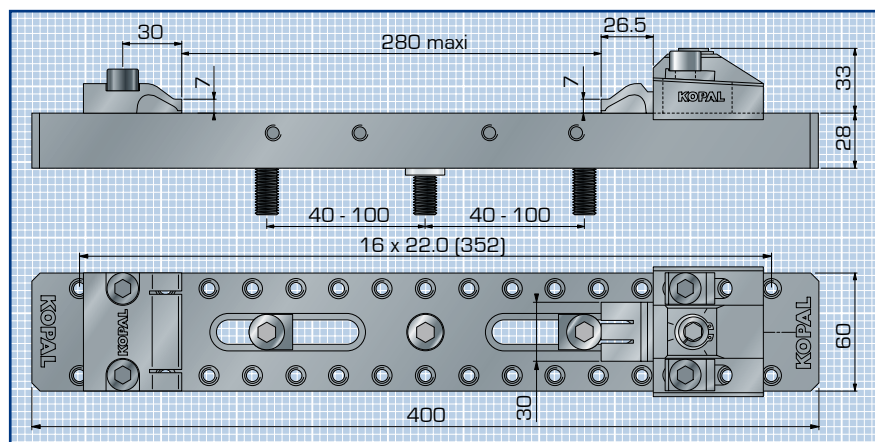
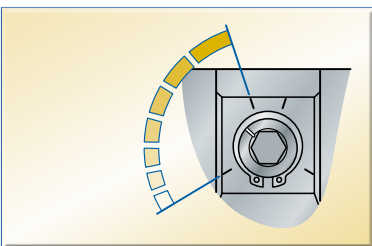

*used with 8 mm
Riser blocks
(page 22)*

10000 N.

Standard Vice

Ref.

Capacity : one workpieces 232 mm max.

09-455

Including :

- ① 1 460 mm mounting bar : 09-040
- ② 1 bar-mounted driving clamp : 09-070
- ③ 1 standard moving clamp/locator : 09-610
- ④ 1 standard fixed clamp : 09-120

*With M 12 clamping screws
and clamping key.*

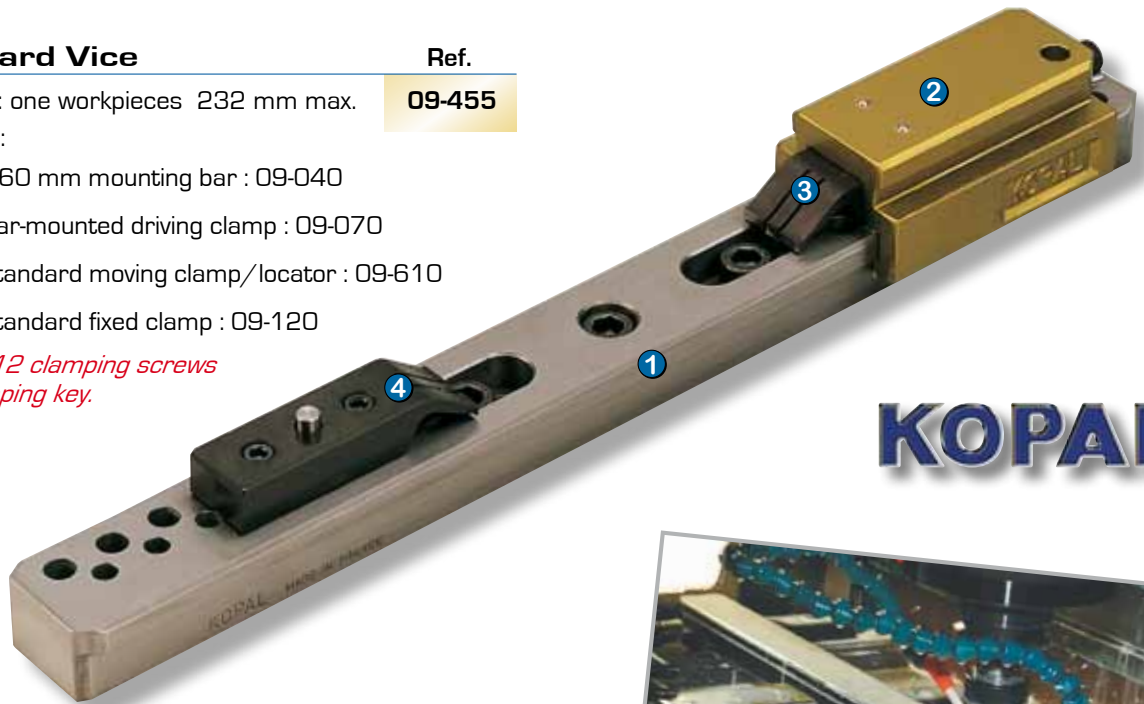

KOPAL

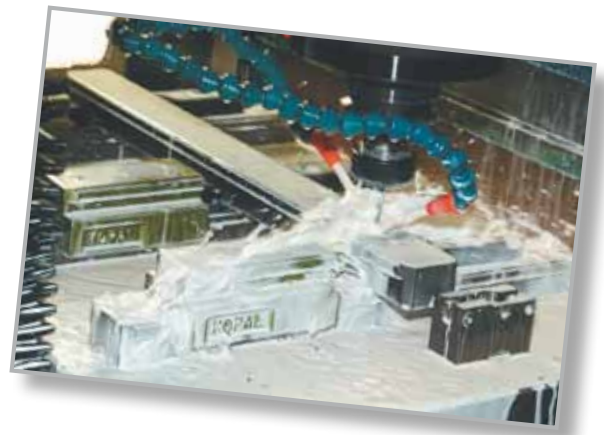

- Complete surfacing
- Through-hole machining

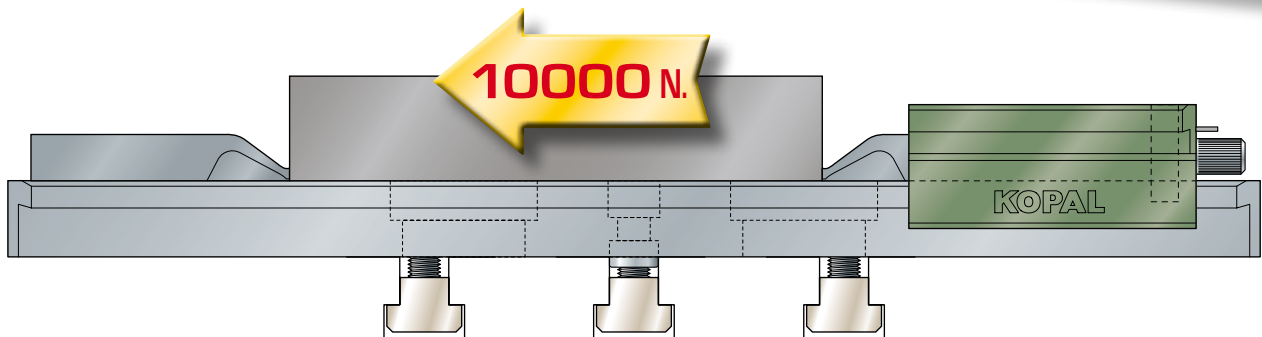

Clamping force : **10000 N.**
Clamping torque : 12 N.m
Clamping range : **20 mm**

Clamping heights

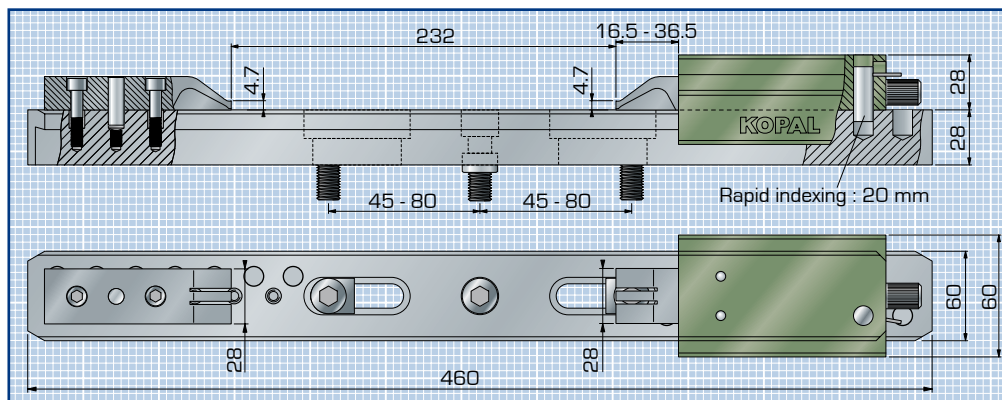
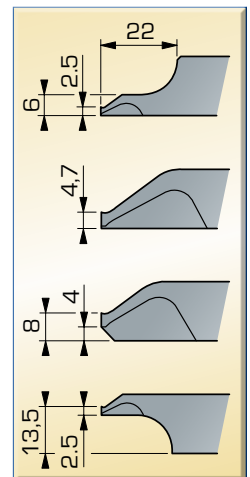

08 KOPAL

MODULAR VICE

Divided Vice

Ref.

Capacity : adapts to workpiece

09-011

Including :

- ① 2 multiple supports : 09-016
height 28 mm
- ② 1 movable indexable jaw : 09-027
clamping range 16 mm
- ③ 1 fixed indexable jaw : 09-081
width 60 mm

*With M 12 clamping screws
and clamping key.*

Clamping force :	22000 N.
Clamping torque :	50 N.m
Clamping range :	16 mm
Positioning :	22 mm

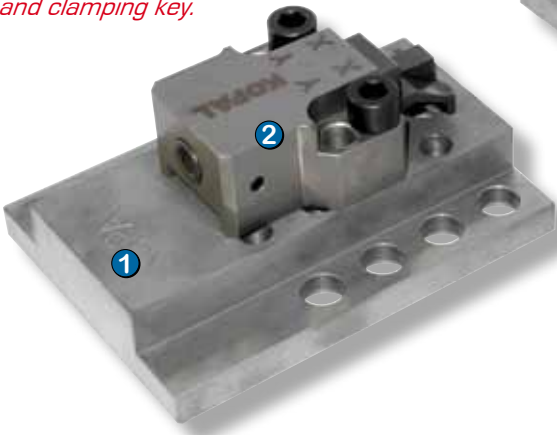

Serrated jaws

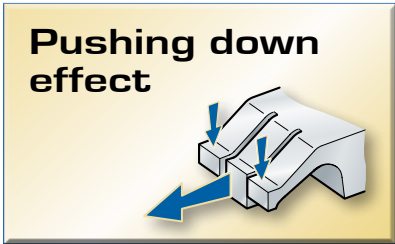
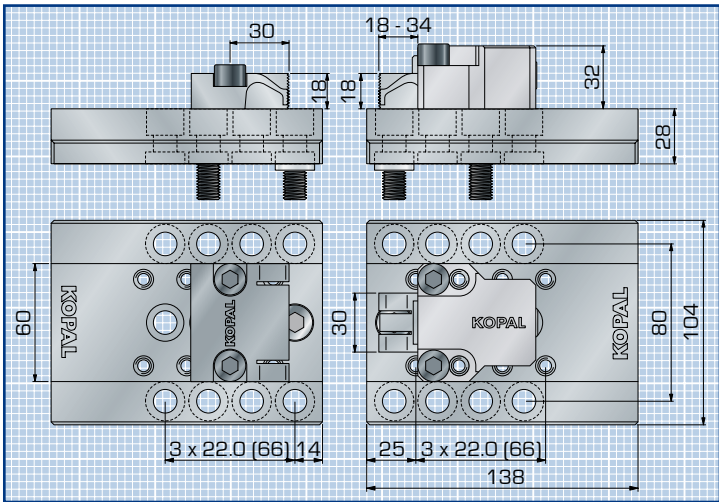
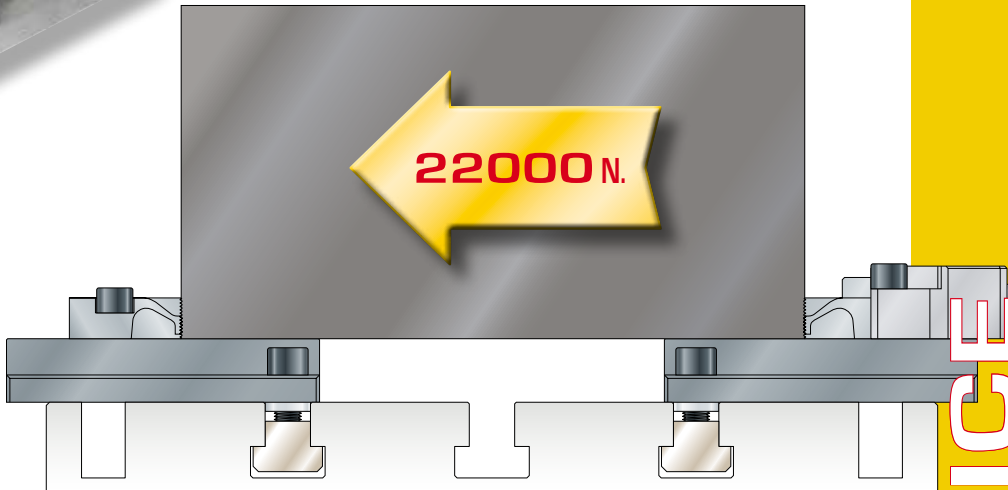
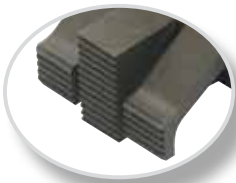

For large workpieces

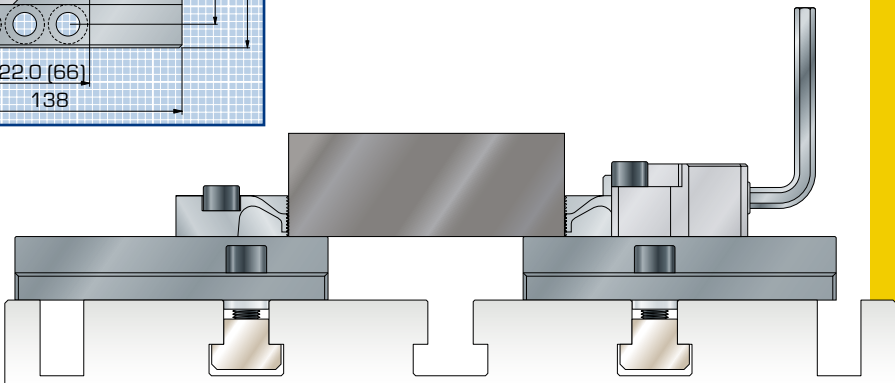

22000 N.

Divided Vice

Capacity : adapts to workpiece

Including :

- ① 2 multiple supports : 09-016
height 28 mm
- ② 1 movable indexable jaw : 09-025
clamping range 16 mm
- ③ 1 fixed indexable jaw : 09-080
width 60 mm

*With M 12 clamping screws
and clamping key.*

Ref.

09-006

Clamping force :	22000 N.
Clamping torque :	50 N.m
Clamping range :	16 mm
Positioning :	22 mm

**Rectified
i jaws**

● **For large
workpieces**

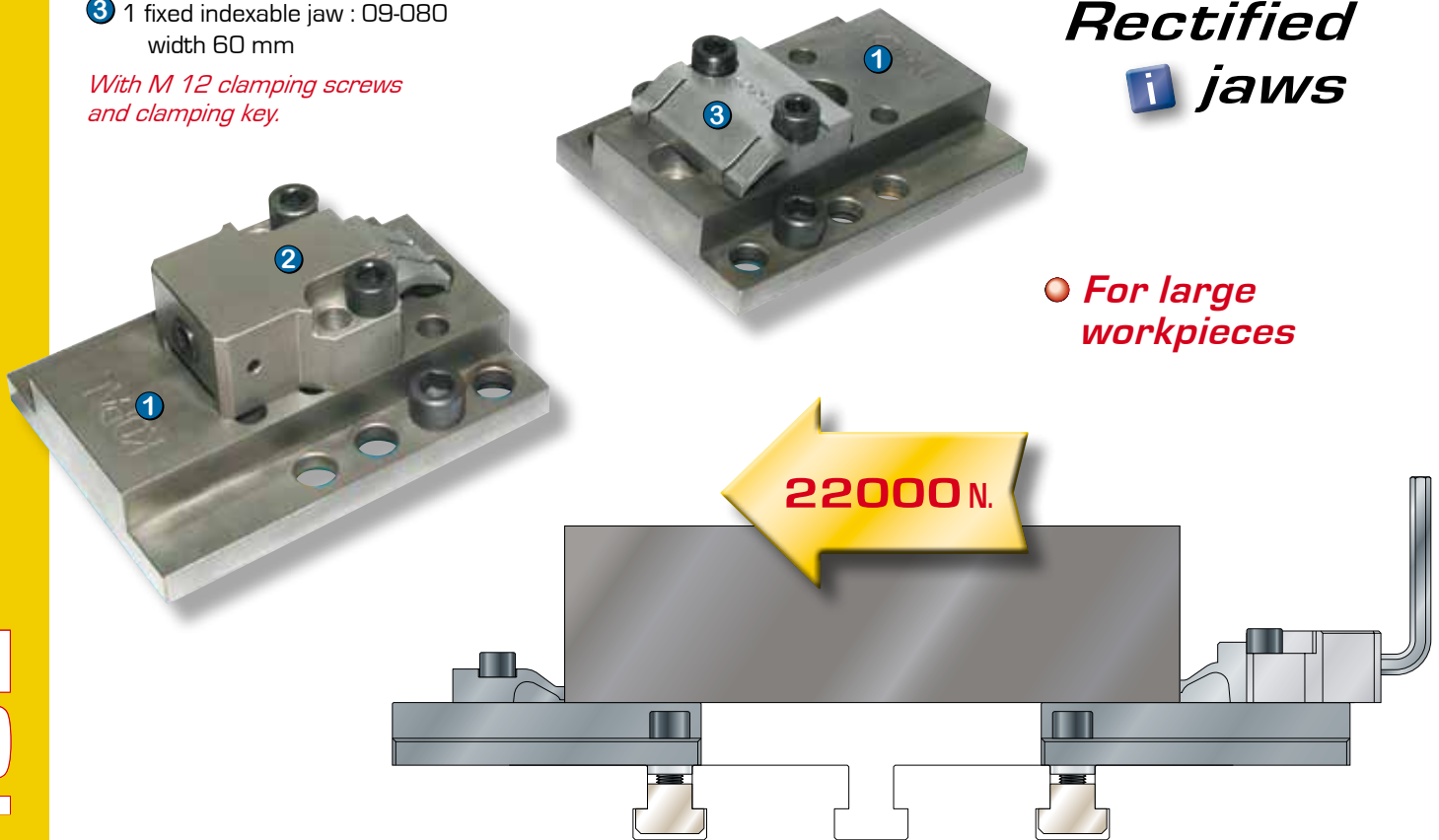

KOPAL®

Modular parts
page 18

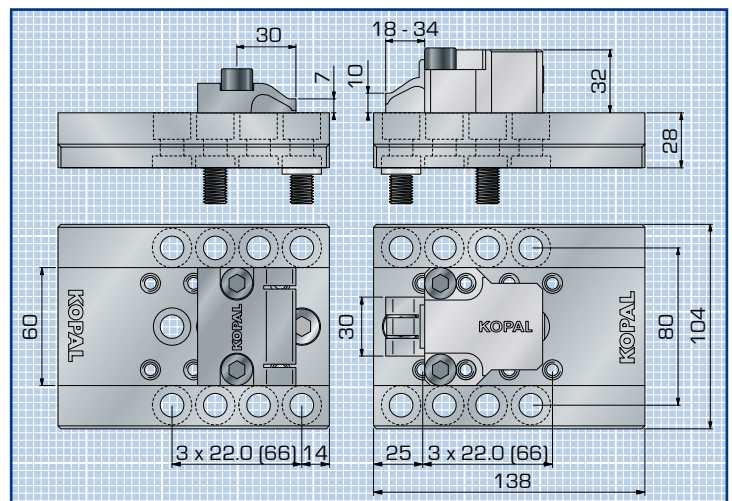

MODULAR VICE

10 KOPAL

Divided Vice with fast clamping

Ref.

09-014

Capacity : adapts to workpiece

Including :

- ① 2 multiple supports : 09-016 height 28 mm
- ② 1 movable indexable jaw : 09-020 clamping range 1.2 mm
- ③ 1 fixed indexable jaw : 09-080 width 60 mm

With M 12 clamping screws and clamping key.



Rectified jaws

Clamping force :	12000 N.
Clamping torque :	70 N.m
Clamping range :	1.2 mm
Adjustment :	25 mm
Positioning :	22 mm

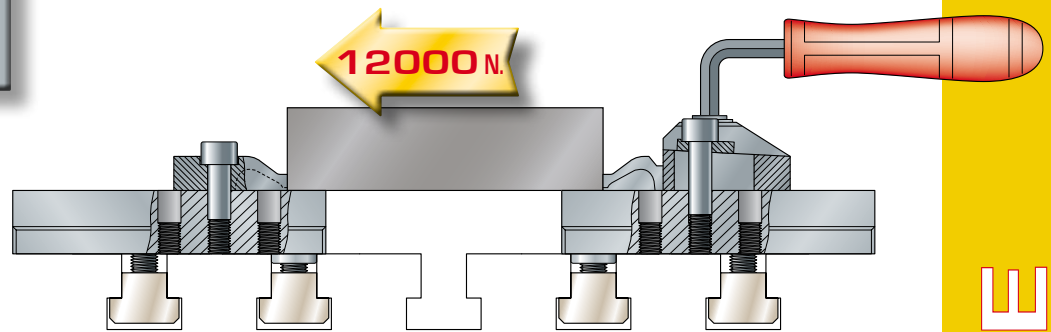

Fast clamping 1/4 turn

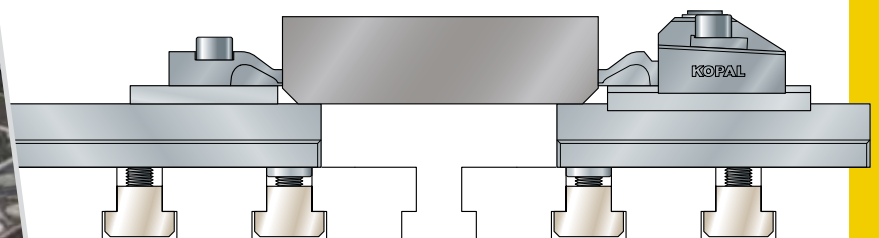
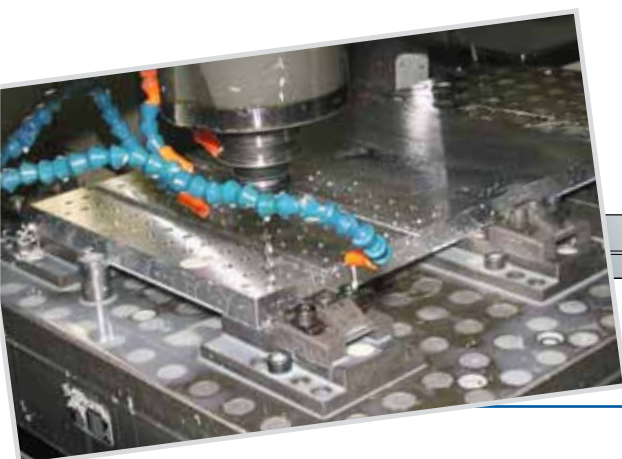
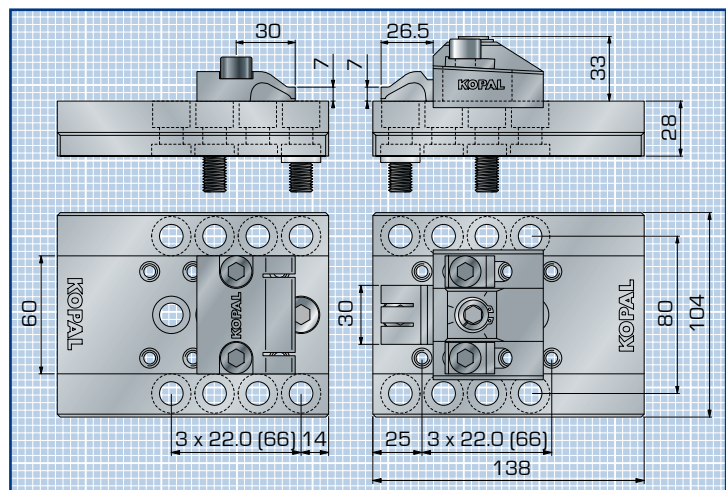
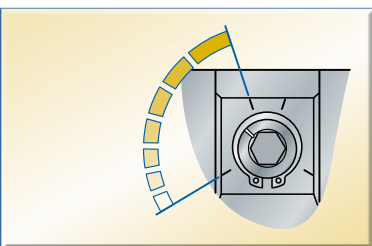

Fixing - Locators

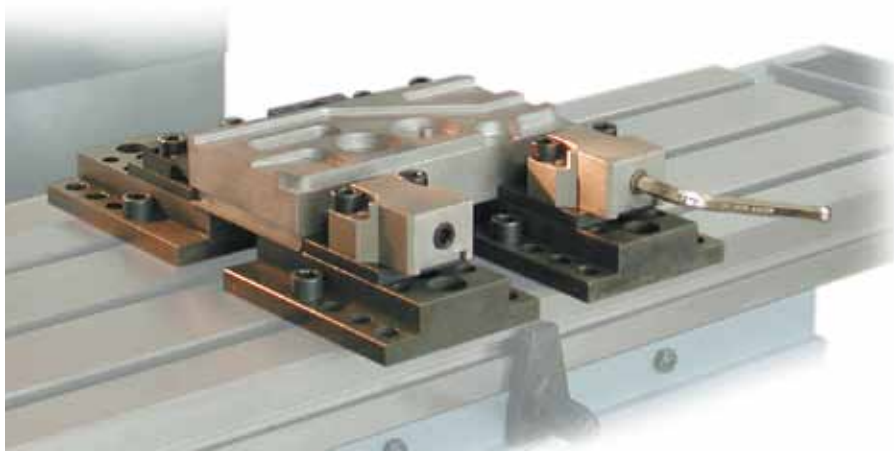

KOPAL®



Lateral stop

Ref.

The lateral stop is positioned in 6 x M 8 points on the side of the mounting bar. It is adjustable in height and length. 8 mm fulcrum rod.

09-086

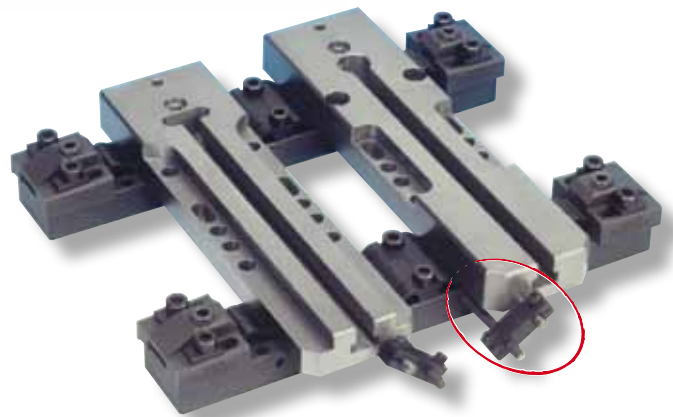

**Rigid
Compact**

These locators enable quick and precise alignment of mounting bars and supports.

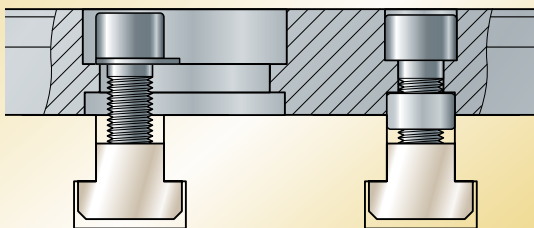

Locators

12000 N. and 22000 N.

For slot size or diameter

Ref.

16 mm	09-886
18 mm	09-888
20 mm	09-890
22 mm	09-892
24 mm	09-894
26 mm	09-896
28 mm	09-898



Locators 10000 N.

For slot size or diameter

Ref.

12 mm	09-220
14 mm	09-225
16 mm	09-230
18 mm	09-215
20 mm	09-235
22 mm	09-240



T-nuts for T-slots M 12

Ref.	Ref.	Ref.	Ref.	Ref.	Ref.	Ref.
14 mm	16 mm	18 mm	20 mm	22 mm	24 mm	28 mm
90-150	90-155	90-160	90-165	90-170	90-175	90-180



Horizontal clamping System KOPAL®



KOPAL®



Presentation	14 - 15
22000 N. - 12000 N.	
Clamping equipments	16 - 17
Modular parts	18 - 24
Fixing - Locators	23
10000 N.	
Clamping equipments	26 - 27
Modular parts	28 - 33
Fixing - Locators	27
6500 N.	
Clamping equipments	34
Modular parts	34 - 35
4000 N. Mini-clamp	
Modular parts	36 - 37
Clamp-slot for table T-slot	38

Principle

Clamping system with horizontal pressure System "with KOPAL moving clamps ©"

The clamping action ensures the **PUSHING DOWN** and **CLAMPING** of the workpiece to be machined..

- ① **PUSHING DOWN** : the flexible parts clamp the workpiece, pressing it down until it makes contact with the rigid part.
- ② **CLAMPING AND POSITIONING** : the rigid part clamps and positions the workpiece in place.

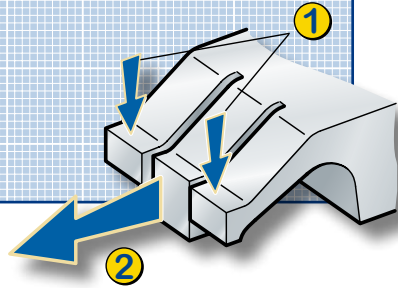

KOPAL horizontal clamping system; the precision and simplicity of a vice, the size of a clamp, and the holding down effect is a bonus!

KOPAL®

Horizontal clamping systems can be adapted to all types of T-slot or modular tables, and provide a clamping force of up to 22000 N.

The system leaves the top surface of the workpiece completely clear, thus allowing machining over the entire surface of the workpiece and ensuring there is no risk of interference with tool movement.

The use of this horizontal system with supports simplifies set-up and reduces adjustment time.



The clamps ensure that mounting is stable, robust and fast, and reduces workpiece changeover time.

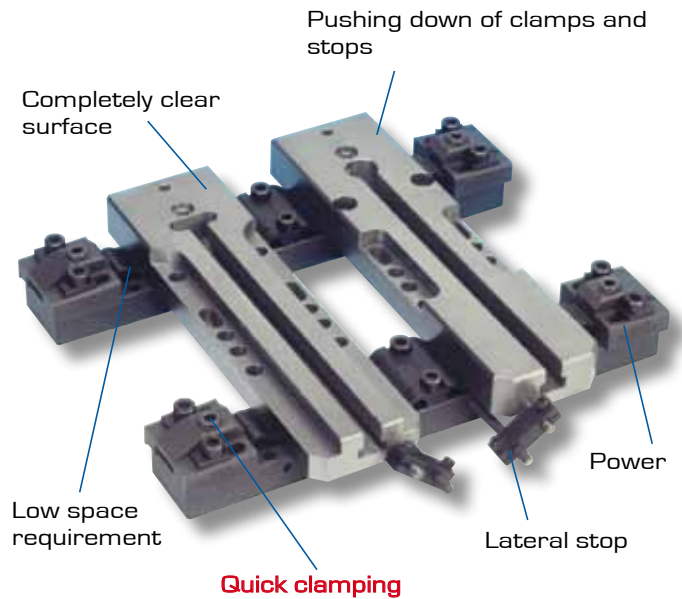

Quick clamping with Eccentric

1/4 turn

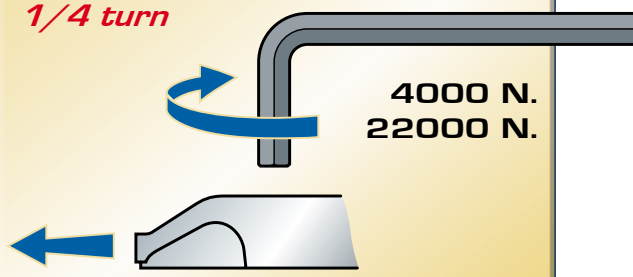

Clamping via thrust screw

long stroke

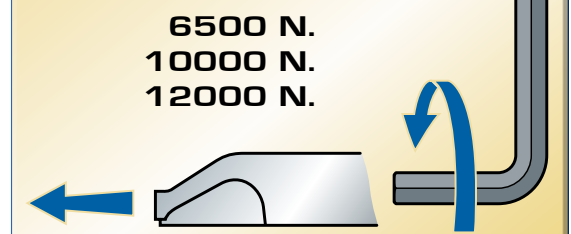

Presentation

T-slot table

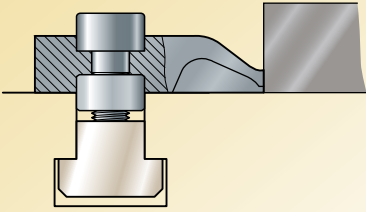

Special machining set-up

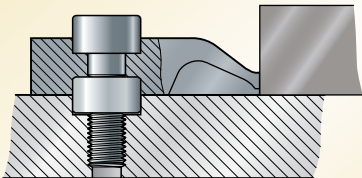

Modular Support for T-slot table for Modular plate

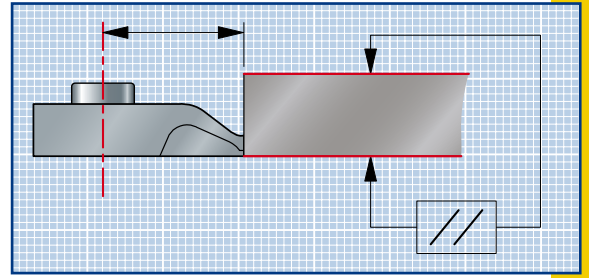
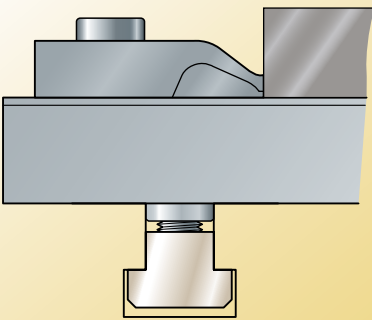

22000 N.
Machining set-ups
Support

page 16



12000 N.
Machining set-ups
Support

page 16



10000 N.
T-slot table
Machining set-ups
Support

page 26



6500 N.
Machining set-ups

page 34



4000 N.
T-slot table
Machining set-ups

page 36



Some references in the 4000 Newton Horizontal Clamping System range are available on request with grounded radii for clamping workpieces with convex radii.

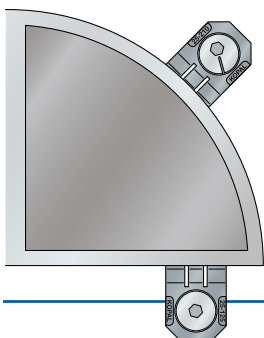

22000 and 12000 Newton

Clamping equipment 22000 N. with rectified jaws for machining set-up

Ref.
09-008

including :

- ① 1 Clamping element : 09-025
clamping height 10 mm
- ② 1 Fixed clamps : 09-080
width 60 mm

With fixing screws and Clamping key

Clamping force : **22000 N.**
Clamping torque : 50 N.m
Clamping range : 16 mm

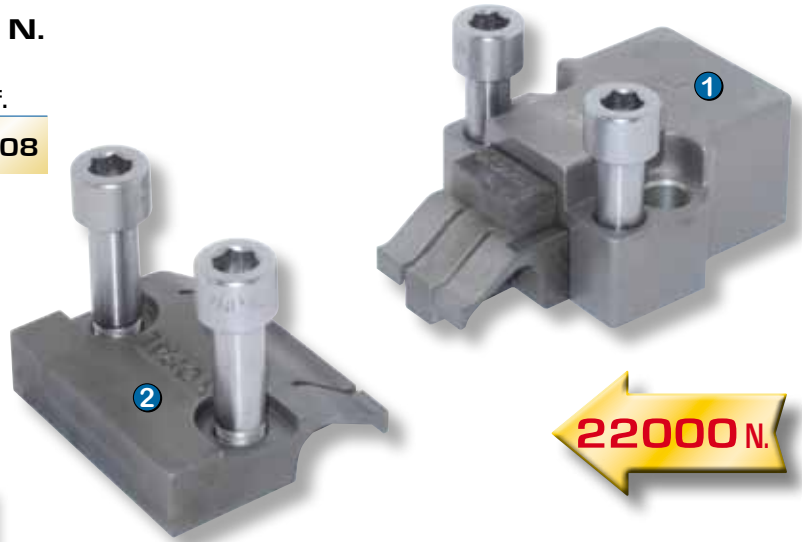

Hardened steel body and moving spring-steel clamp which pushes down and clamps the workpiece

KOPAL

Clamping equipment 22000 N. with serrated jaws for machining set-up

Ref.
09-003

including :

- ① 1 Clamping element : 09-027
clamping height 16 mm
- ② 1 Fixed clamps : 09-081
width 60 mm

With fixing screws and Clamping key



12000 N.

Clamping equipment 12000 N. with rectified jaws for machining set-up

Ref.
09-012

including :

- ① 1 Clamping element : 09-021
clamping height 7 mm
- ② 1 Fixed clamps : 09-080
width 60 mm

With fixing screws and Clamping key



**Fast clamping
1/4 turn**

Eccentric with 8 mm hexagonal socket
clamping with left or right turn or left

Clamping force : **12000 N.**
Clamping torque : 70 N.m
Clamping range : 1.2 mm
Adjustment : 25 mm

22000 and 12000 Newton

MOUNTING

Drill 2 holes :
Centre distance
44.00 ± 0.005

M 10 depth 28 mm
Ø 10,2 H 6
depth 14 mm

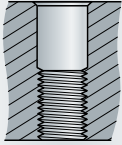

● Machining assembly is carried out according to workpiece dimensions

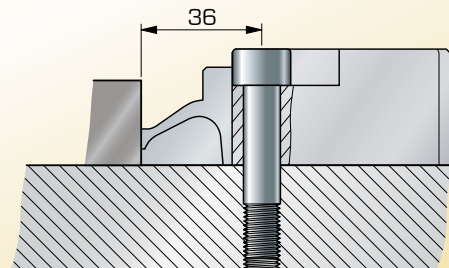
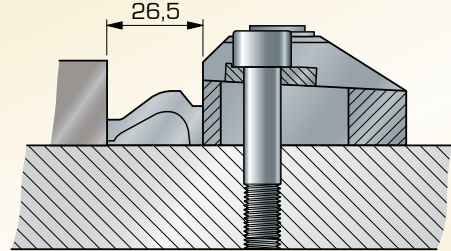
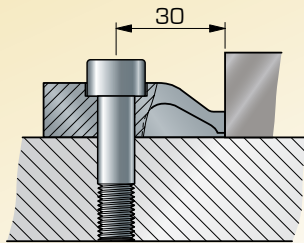

Mount the elements with 2 rectified screws
Ø 10.2 - M 10.
The diameter of 10.2 mm allows precise
positioning of stops

22000 N. - 09-008 - 09-003

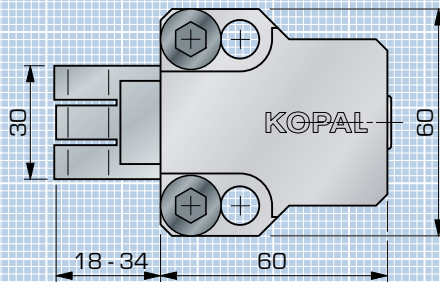
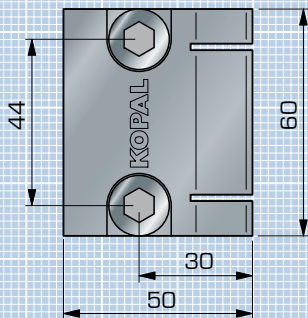

12000 N. - 09-012

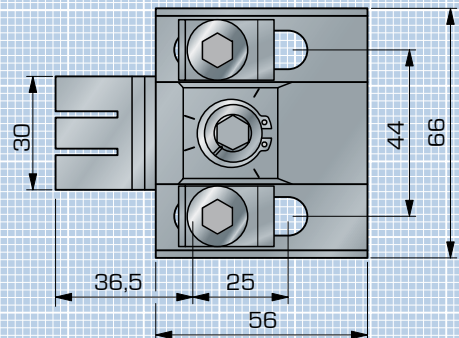
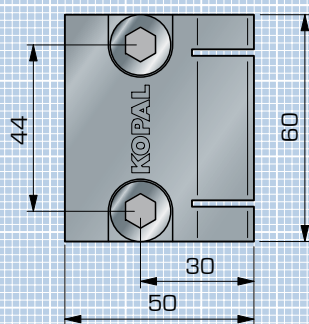

HORIZONTAL CLAMPING

22000 and 12000 Newton

Clamping element

Hardened steel body with clamping eccentric and moving spring-steel clamp which pushes down and clamps the workpiece.

With fixing screws and Clamping key

Clamping element 22000 N.	Ref.
Rectified jaws clamping height 10 mm	09-020
Serrated jaws clamping height 18 mm	09-027
Clamping key (8 SW)	09-088



Clamping force : **22000 N.**
Clamping torque : 50 N.m
Clamping range : 16 mm

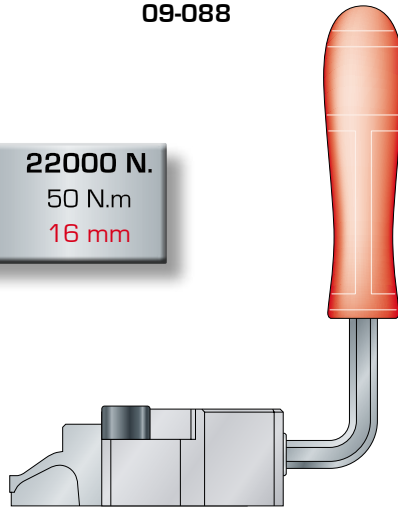

Pushing down effect

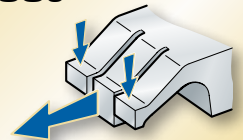

Mount the elements with 2 rectified screws $\varnothing 10.2 - M 10$.
The diameter of 10.2 mm allows precise positioning of stops



KOPAL

Clamping element with fast clamping

Hardened steel body with clamping eccentric and moving spring-steel clamp which pushes down and clamps the workpiece.

With fixing screws, washers and Clamping key

Clamping element 12000 N.	Ref.
Rectified jaws clamping height 7 mm	09-021
Clamping key (8 SW)	09-088



Clamping force : **12000 N.**
Clamping torque : 70 N.m
Clamping range : 1.2 mm
Adjustment : 25 mm

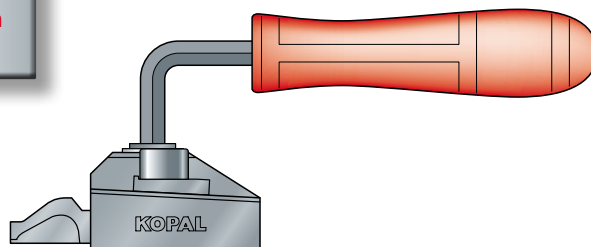

**Fast clamping
1/4 turn**

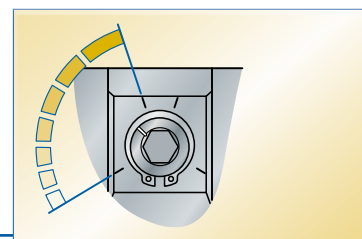

22000 and 12000 Newton

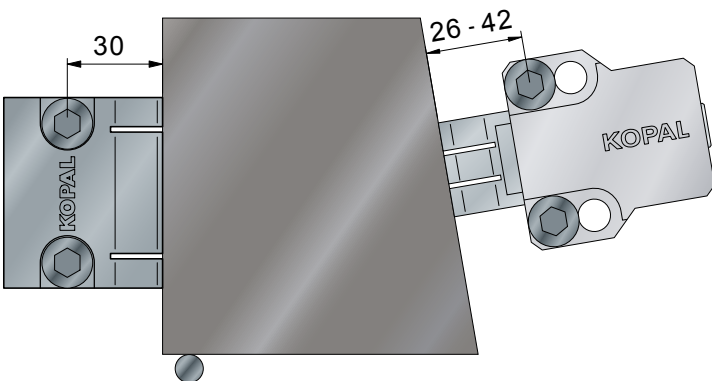
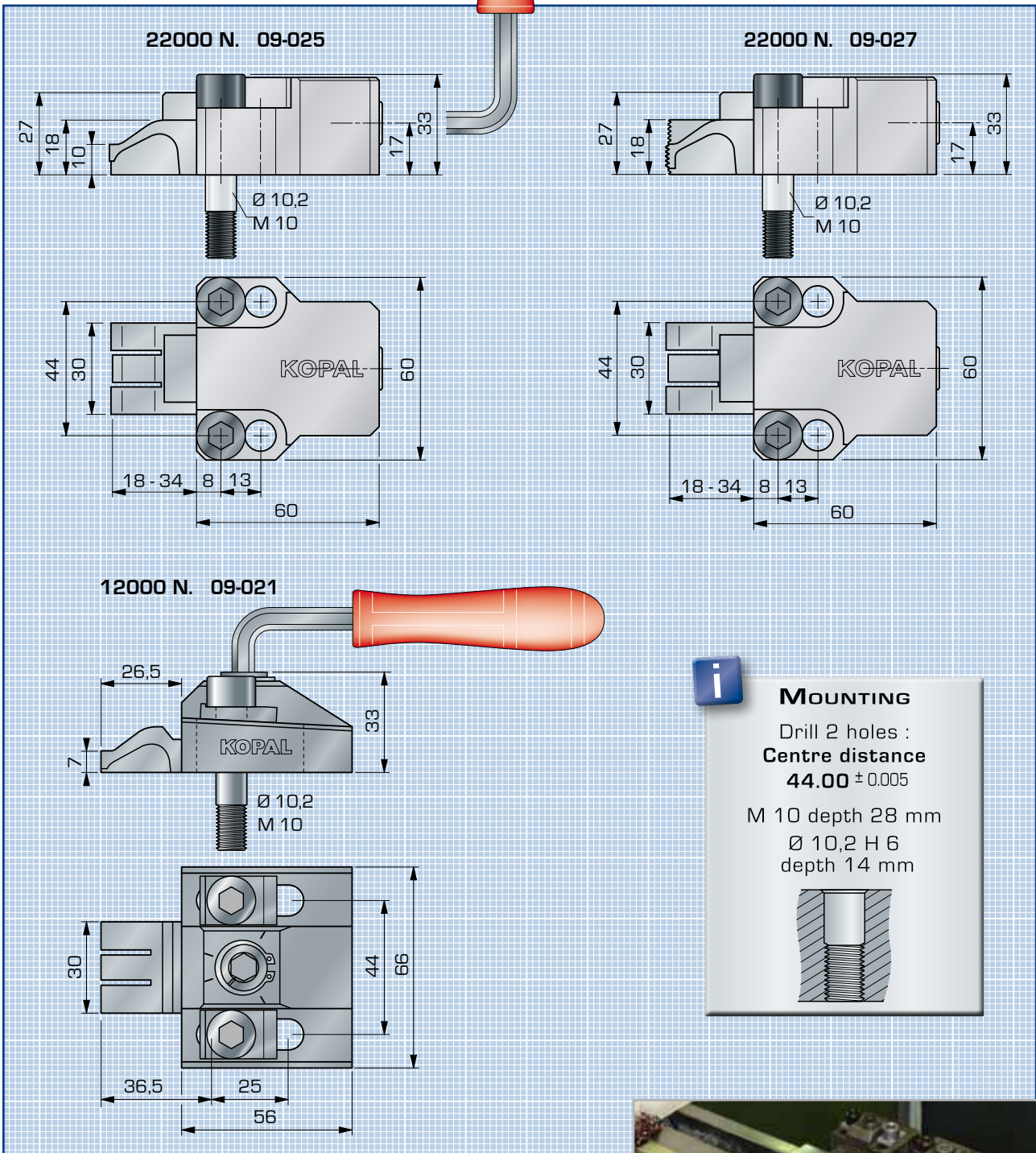

HORIZONTAL CLAMPING

22000 and 12000 Newton

Fixed Rectified jaws (Stops)

Spring-steel clamp / locator

With fixing screws

Stop with pushing down effect Ref.

clamping height 7 mm

Standard clamp / locator 09-080

Double fixed clamp / locator 09-082

For clamping 2 facing workpieces



Fixed Serrated jaw (Stop)

Spring-steel clamp / locator

With fixing screws

Stop with pushing down effect Ref.

clamping height 18 mm

Fixed clamp / locator 09-081

For raw piece



09-080 - 09-082
height 7 mm

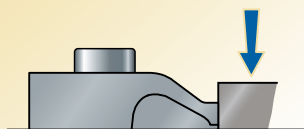

09-081
height 18 mm

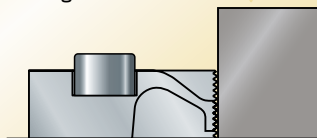

MOUNTING

Drill 2 holes :
Centre distance
44.00 ± 0.005

M 10 depth 28 mm
Ø 10,2 H 6
depth 14 mm

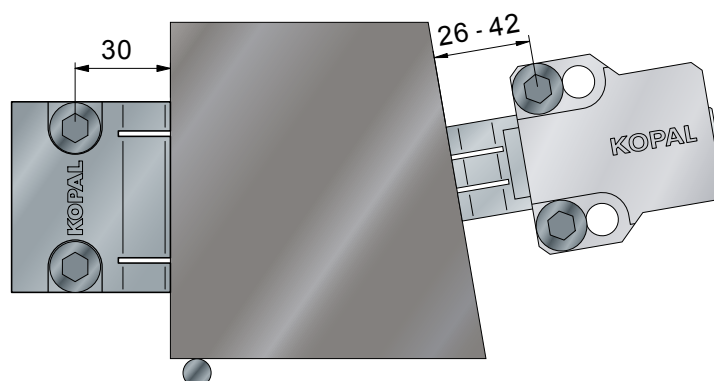
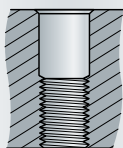

22000 and 12000 Newton

Rectified centring screws

Ref.

Ø 10,2 - M 10 screws for mounting clamping elements and stops.

39 mm screw

09-874

For mounting single fixed clamps

47 mm screw

09-876

For mounting clamping elements and fixed clamps with riser blocks.

55 mm screw

09-878

For mounting clamping elements with riser block.

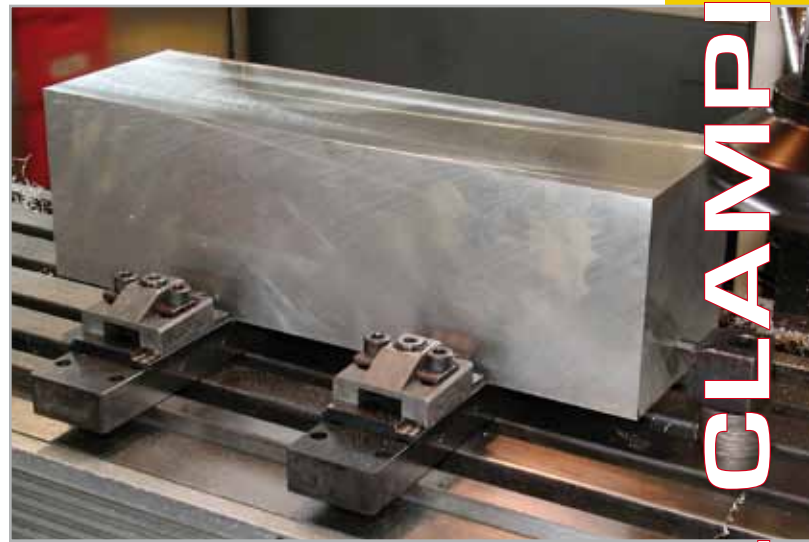
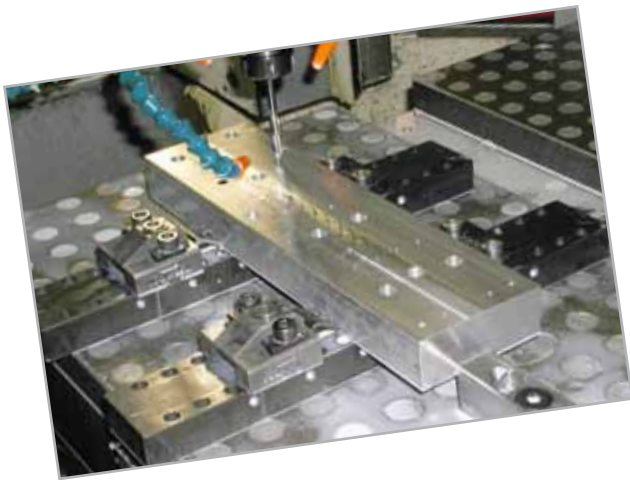
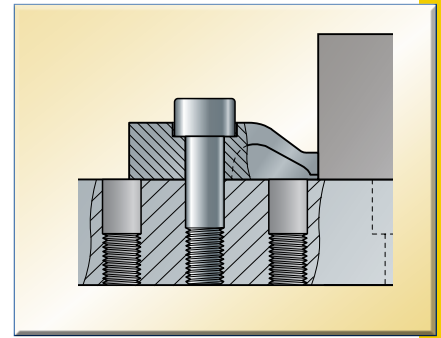

KOPAL

HORIZONTAL CLAMPING

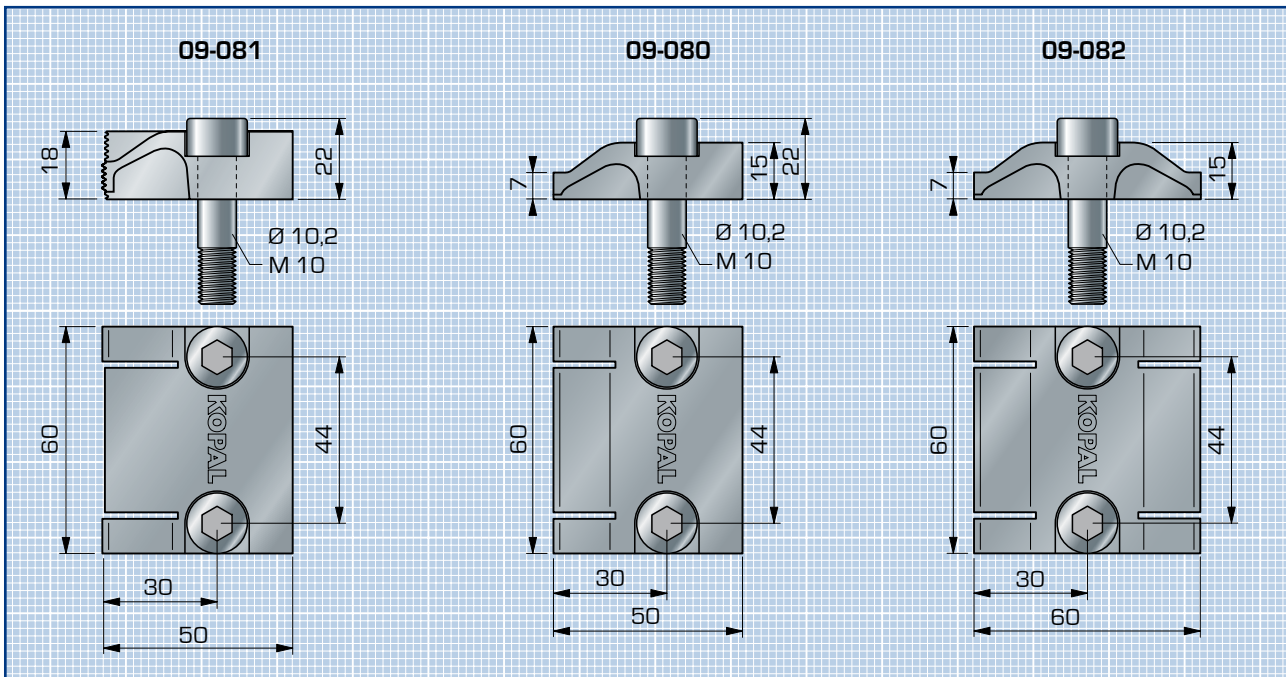

22000 and 12000 Newton

Support (mounting bar)

Hardened steel reference elements
Rectified thickness.

2 rows of holes (H6) ensure that clamping components or fixed clamps / locators (stops) are precisely positioned in relation to the centring locator \varnothing 16 - 28 mm, located under the lower side of the bar.

400 mm mounting bar **09-015**

Capacity (width of workpiece) :
1 workpiece 260 mm max
2 workpieces 120mm max

With M12 fixing screws



Multiple support

For large workpieces

09-016

The workpiece can be clamped on the table or raised by 28 mm.

With M12 fixing screws

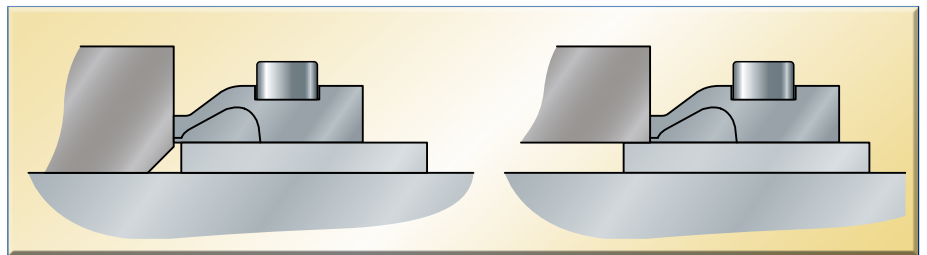

8 mm riser blocks

Ref.

Made from hardened steel with rectified thickness, they raise the clamping height or the workpiece by 8 mm

- | | |
|---|---------------|
| 1 Riser block for clamping element on mounting bar
Use 55 mm screws (09-878). | 09-866 |
| 2 Riser block for clamping element on special machining set-up
Use 55 mm screws (09-878). | 09-867 |
| 3 Riser block for standard fixed clamp
Use 47 mm screws (09-876). | 09-868 |
| 4 Riser block for double-ended fixed clamp
Use 47 mm screws (09-876). | 09-870 |

22000 and 12000 Newton

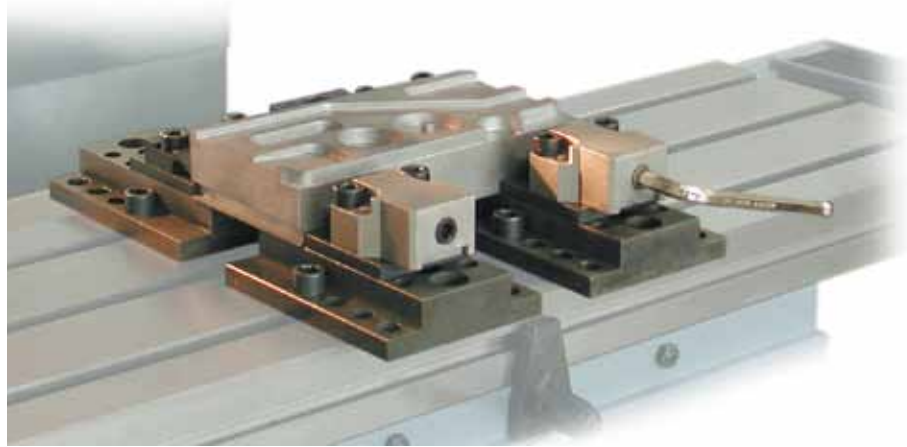

Lateral stop

Ref.

The lateral stop is positioned in 6 x M 8 points on the side of the mounting bar. It is adjustable in height and length. 8 mm fulcrum rod.

09-086

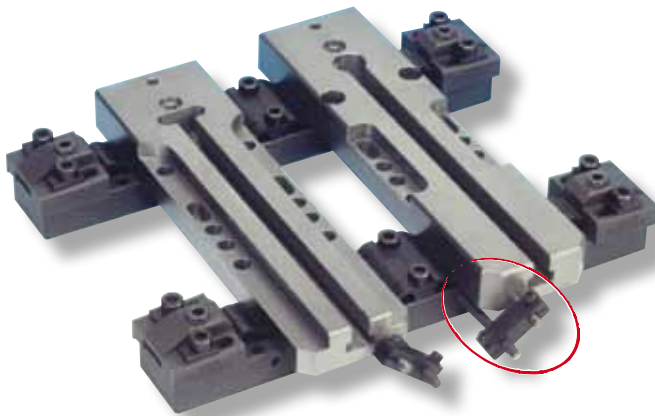

**Rigid
Compact**

Locators

Ref.

Made from hardened rectified steel with M 14 internal screw thread for extraction.

For slot size or diameter :

- 16 mm
- 18 mm
- 20 mm
- 22 mm
- 24 mm
- 26 mm
- 28 mm



- 09-886
- 09-888
- 09-890
- 09-892
- 09-894
- 09-896
- 09-898

These locators enable quick and precise alignment of mounting bars and supports..

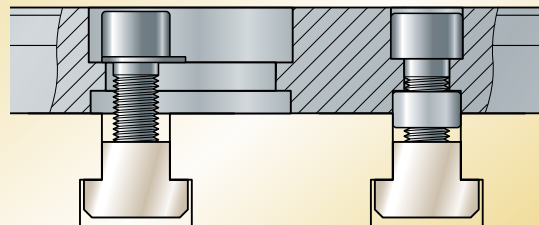

T-nuts for T-slots M 12

Ref.	Ref.	Ref.	Ref.	Ref.	Ref.	Ref.
14 mm	16 mm	18 mm	20 mm	22 mm	24 mm	28 mm
90-150	90-155	90-160	90-165	90-170	90-175	90-180

22000 and 12000 Newton

HORIZONTAL CLAMPING

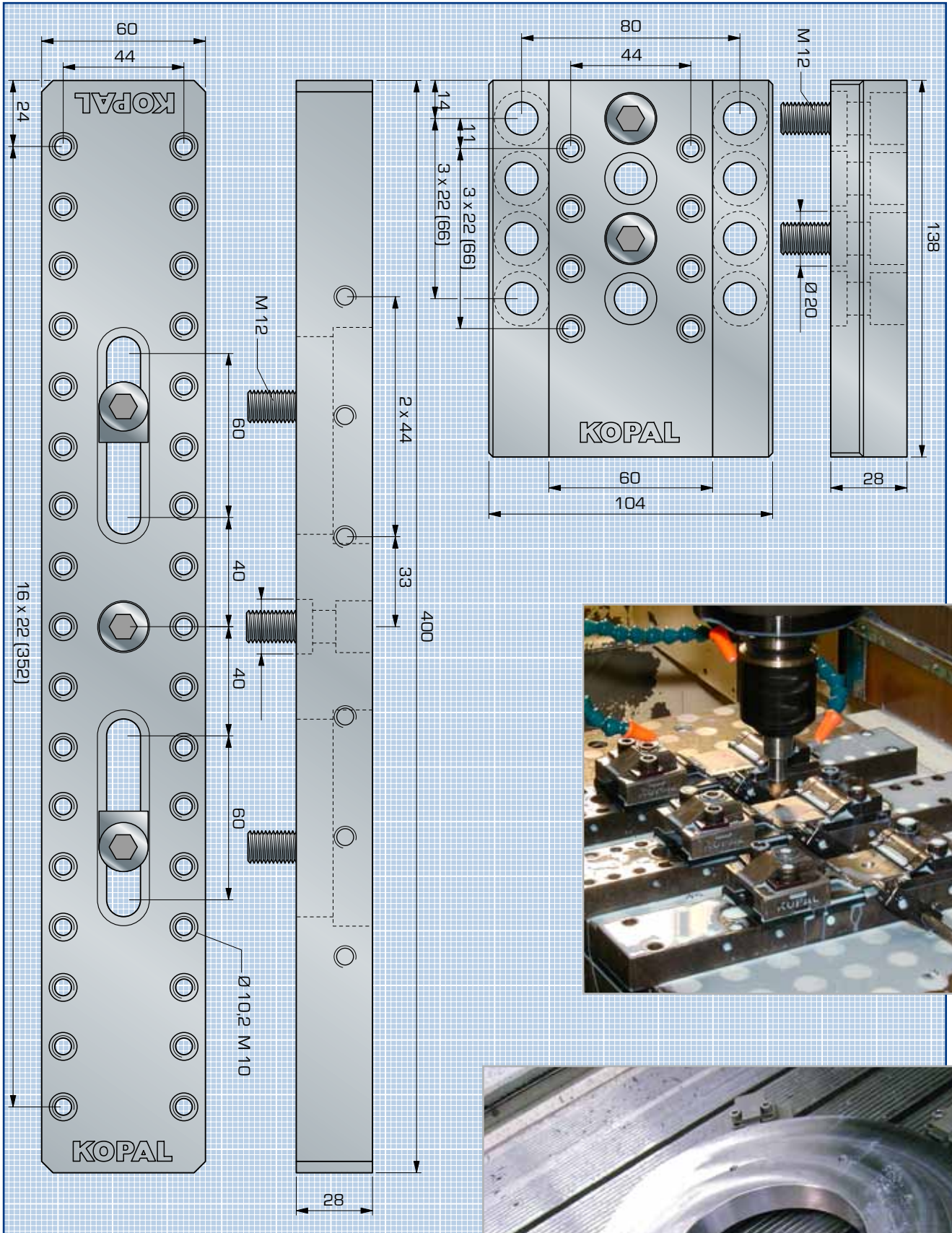



KOPAL®

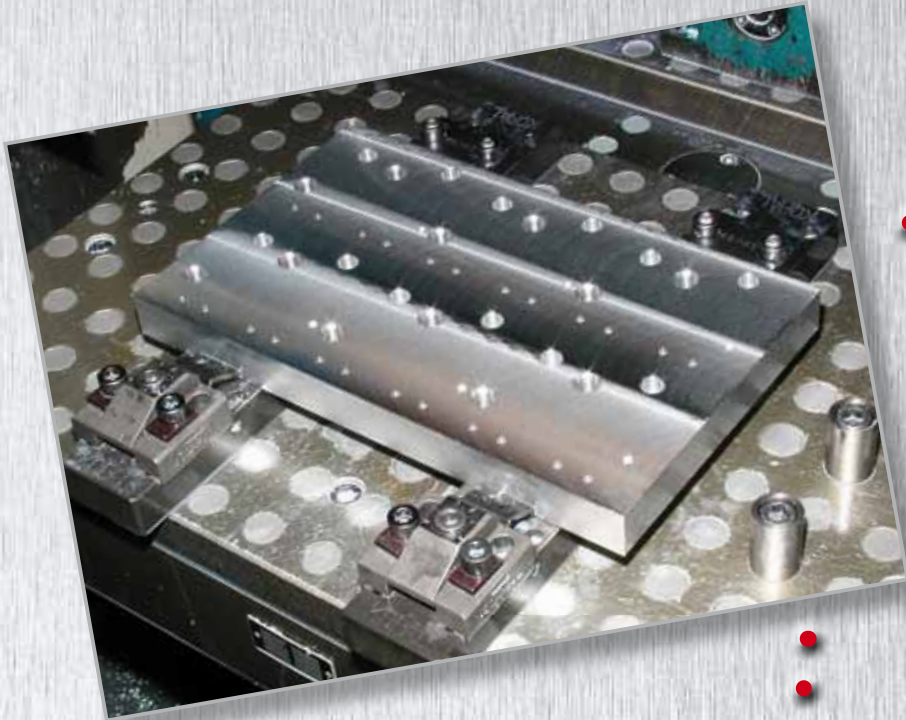

HORIZONTAL CLAMPING

10000 Newton

10000 N. Equipment for T-slot table

With fixing screw and clamping key

M 10 Equipment

Ref. **09-495**

Including :

- ① 1 Driving clamp M 10 09-065
- ② 1 standard moving clamp 09-610
- ③ 1 standard M 10 clamp / locator 09-140

M 12 Equipment

Ref. **09-496**

Including :

- ① 1 Driving clamp M 12 09-068
- ② 1 standard moving clamp 09-610
- ③ 1 standard M 12 clamp / locator 09-141

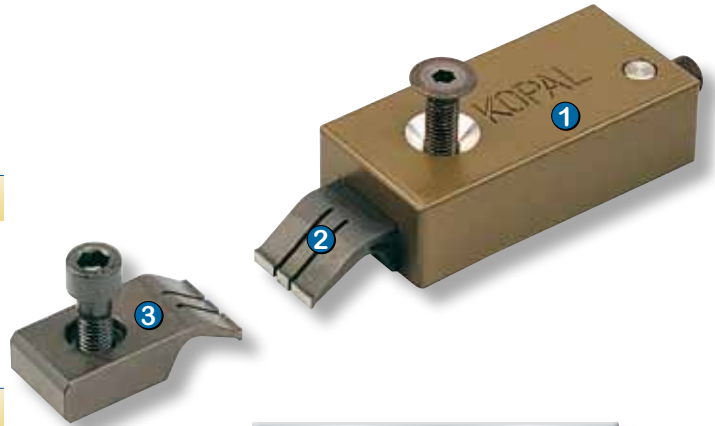

Clamping force : **10000 N.**
 Clamping torque : **12 N.m**
 Clamping range : **20 mm**

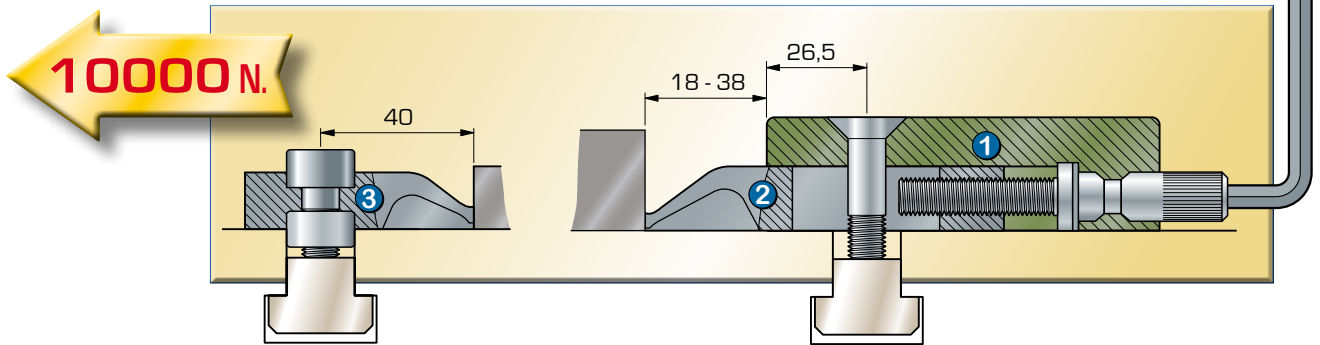

Machining assembly is carried out according to workpiece dimensions

- Simple and compact assembly
- Quick clamping
- Multiple applications

10000 N. Equipment for Machining set-ups

With fixing screws and clamping key

Standard Equipment

Ref. **09-451**

Including :

- ① 1 Driving clamp 09-090
- ② 1 standard moving clamp 09-610
- ③ 1 standard M 10 clamp / locator 09-140

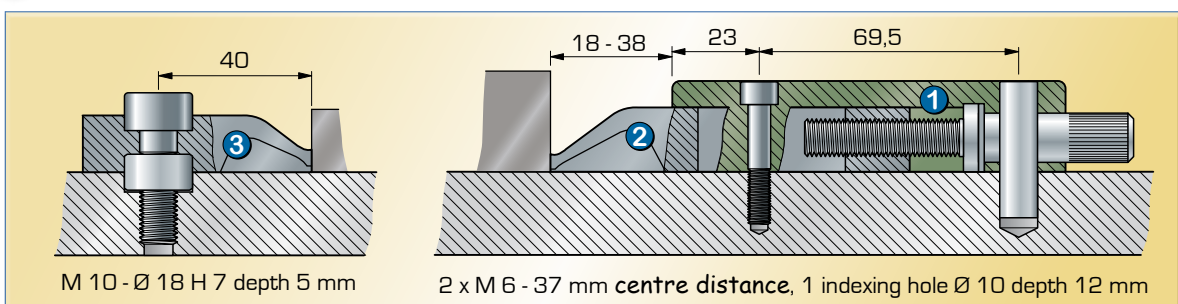

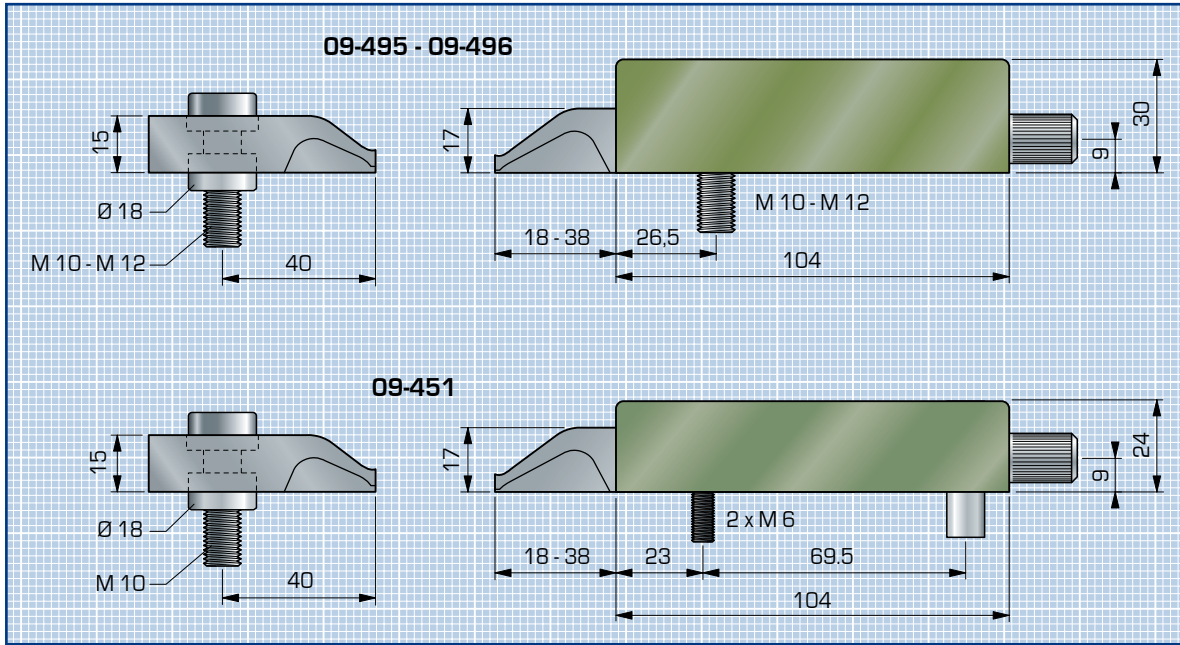

Fixing - Locators

KOPAL

Centring locators

Ref.

For slot sizes or diameters :

- 12 mm
- 14 mm
- 16 mm
- 18 mm
- 20 mm
- 22 mm



- 09-220
- 09-225
- 09-230
- 09-215
- 09-235
- 09-240

These locators allow immediate alignment of the stops and prevent the clamping components from sliding.

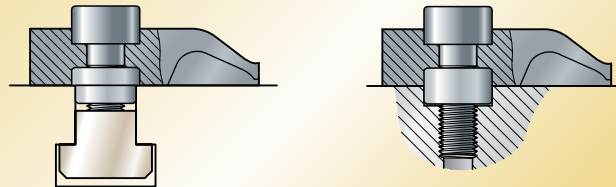

These T-nuts prevent the clamps and driving clamps from sliding during lengthwise slots use.

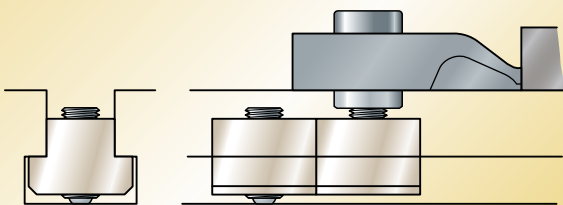

Anti sliding T-nuts

Ref.

For slot sizes :

- 12 mm
- 14 mm
- 16 mm
- 18 mm
- 20 mm
- 22 mm



- 09-420
- 09-425
- 09-431
- 09-436
- 09-437
- 09-443



T-nuts

	Ref.	Ref.	Ref.	Ref.	Ref.	Ref.	Ref.
	14 mm	16 mm	18 mm	20 mm	22 mm	24 mm	28 mm
M 10	90-105	90-110	90-115	90-120	90-125	90-130	90-135
M 12	90-150	90-155	90-160	90-165	90-170	90-175	90-180

10000 Newton

Clamp body

Made in Aluminium, with pressure screw.

for mounting bars or half-mounting bars

Moving clamp 09-610 to 09-625

The body quickly indexes into position and can be placed over another clamping body and used as a 28 mm extra-raised component.

With clamping key



Ref.

Bar-mounted driving clamp

09-070



Clamping force : **10000 N.**
 Clamping torque : 12 N.m
 Clamping range : **20 mm**

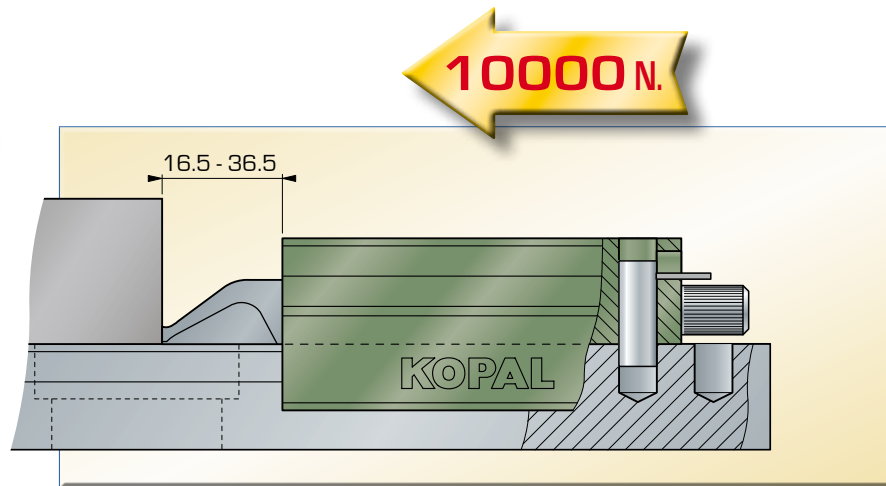

KOPAL



Clamp body

Made in Aluminium, with pressure screw.

for T-slot table

Moving clamp 09-610 to 09-625

With fixing screw and clamping key

Ref.

M 10 driving clamp

09-065

M 12 driving clamp

09-068

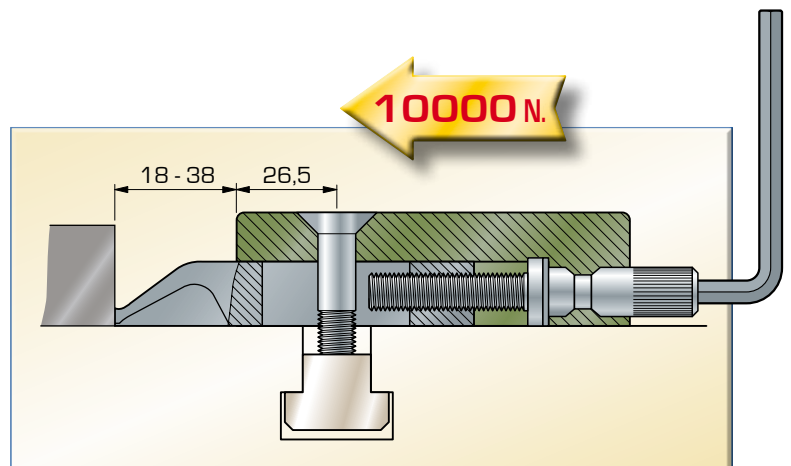

HORIZONTAL CLAMPING



28 KOPAL

10000 Newton

Clamp body

Made in Aluminium, with pressure screw.

for machining set-ups

Moving clamp 09-610 to 09-625

With fixing screws and clamping key



Ref.

09-090

Table-mounted driving clamp

Fixed in place with 2 x M6 screws and $\varnothing 10$ pinning

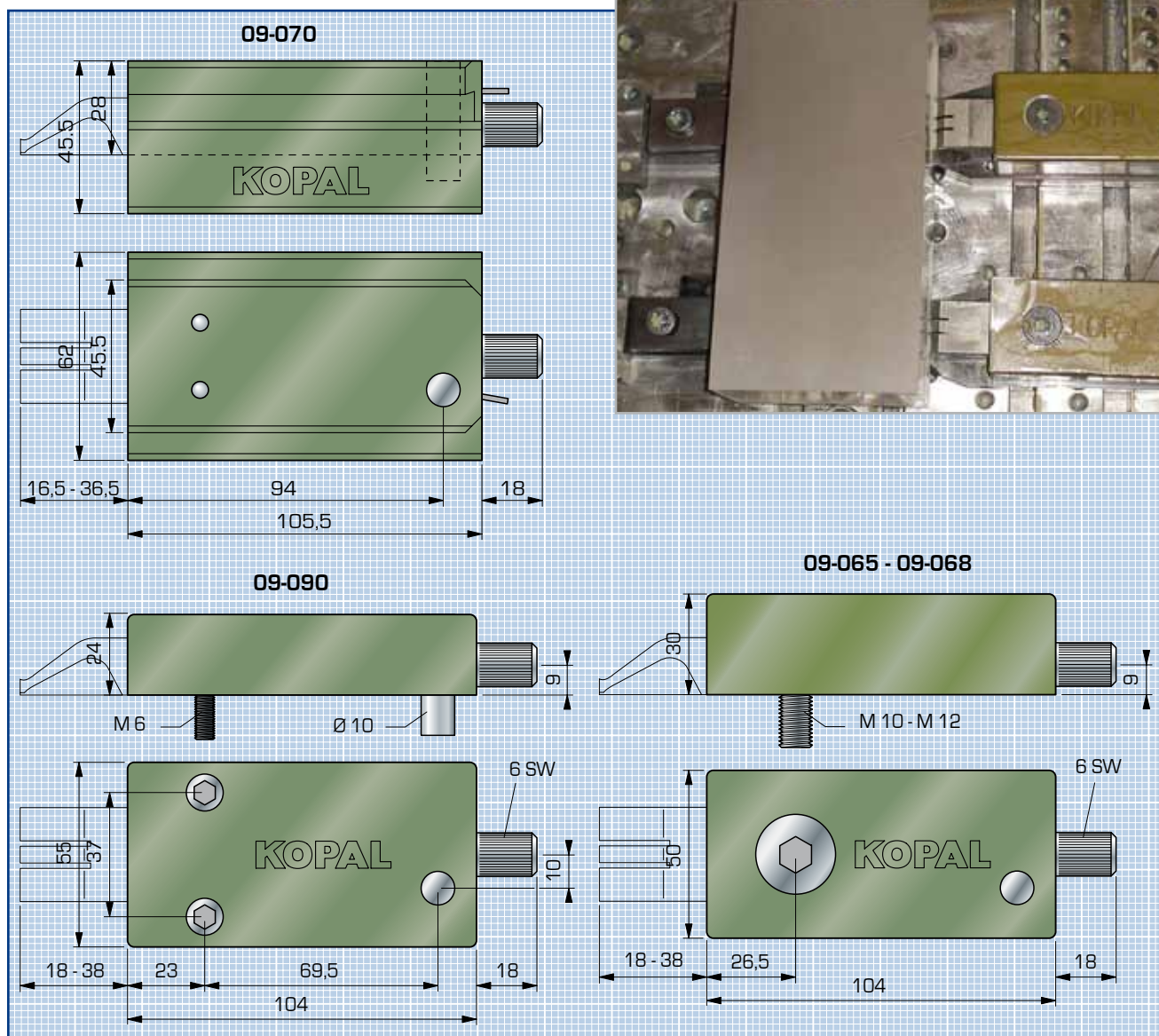
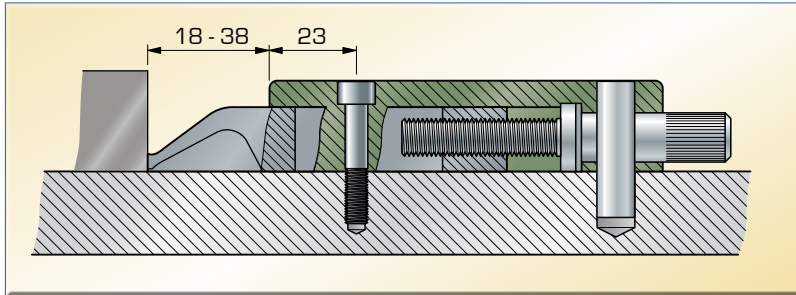

HORIZONTAL CLAMPING

10000 Newton

Moving clamps

Clamps made of spring steel
**for clamping body 09-065, 09-068, 09-070
 and 09-090**
 (work with the body pressure screw)

KOPAL

Low moving clamp
 clamping height 2,5 mm

Ref.
09-615

Standard moving clamp
 clamping height 4,7 mm

09-610

Raised moving clamp
 clamping height 8 mm

09-620

Extra-raised moving clamp
 clamping height 13,5 mm

09-625

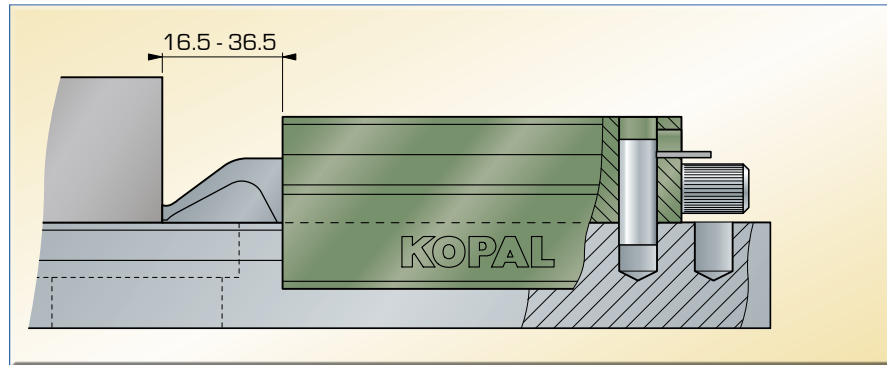

Clamping heights

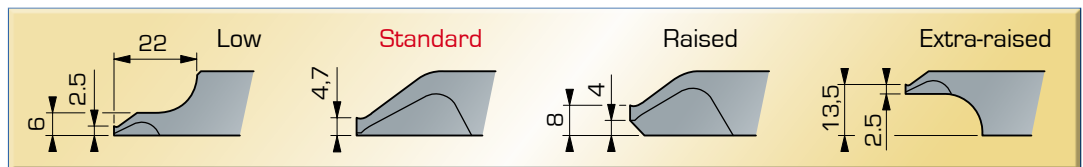

HORIZONTAL CLAMPING

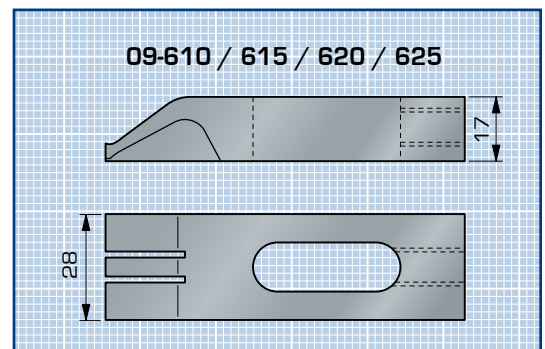
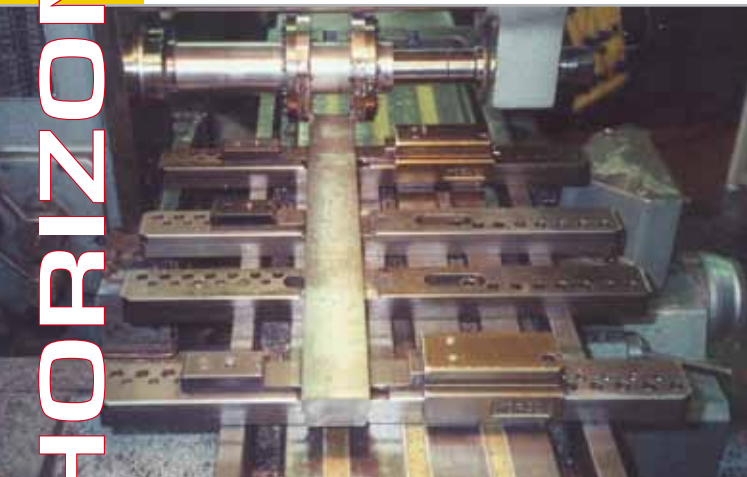

Fixed clamps / locators

Made of spring steel

for mounting bar and half-mounting bar

(with M 6 clamping screws and positioning pin)

	Ref.
Low fixed clamp / locator clamping height 2,5 mm	09-125
Standard fixed clamp / locator clamping height 4,7 mm	09-120
Raised fixed clamp / locator clamping height 8 mm	09-130
Extra-raised fixed clamp / locator clamping height 13,5 mm	09-135

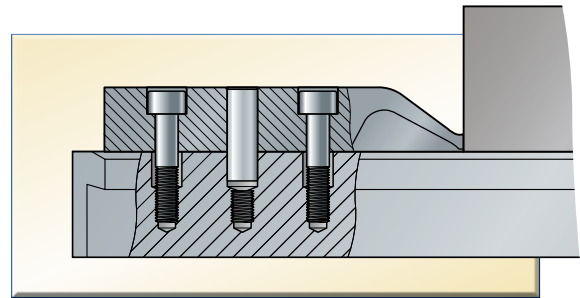

The contact side of the stops is machined in relation to the centring locator, thus ensuring the workpiece is correctly positioned.

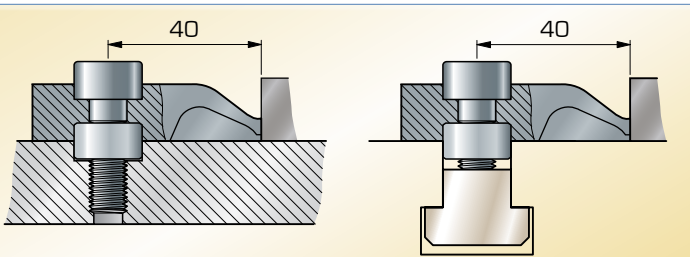

Table-mounted clamps/locators

Made of spring steel

for T-slot table and machining set-ups

(with clamping screw and \varnothing 18 mm locating)

	Ref.
Low clamp/locator clamping height 2,5 mm	
M 10	09-143
M 12	09-144
Standard clamp/locator clamping height 6 mm	
M 10	09-140
M 12	09-141
Extra-raised clamp/locator clamping height 13,5	
M 10	09-142
Double-ended clamp clamping height 6 mm	
M 10	09-145
M 12	09-147

09-140 / 141 / 142 / 143 / 144

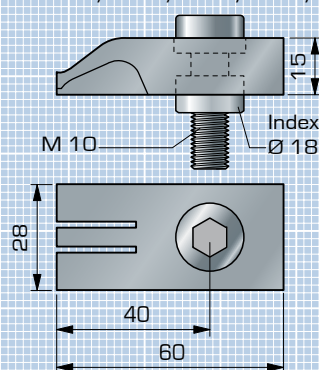

09-145 / 147

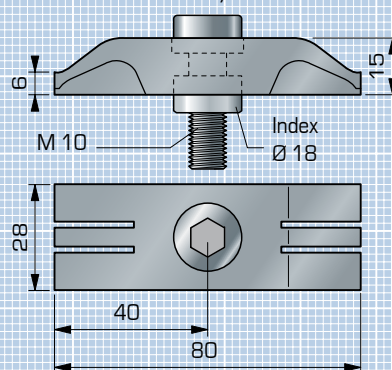

09-120 / 125 / 130 / 135

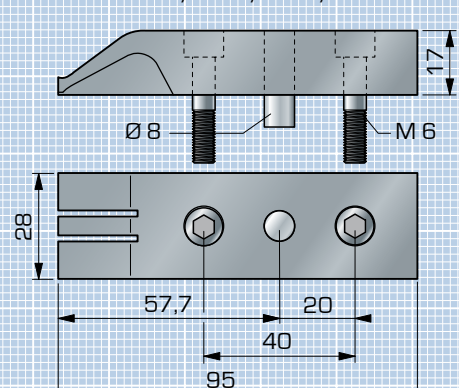

10000 Newton

Support (mounting bar)

Rectified cast-iron mounting bar, raises the workpiece by 28 mm in order to perform through-hole machining. It is very simple to install and can be quickly adjusted.

With M12 fixing screws

460 mm mounting bar 09-040

For clamping elements and stops



Mounted with 3 x M 12 screws and special washers

Support (1/2-mounting bar)

Rectified cast-iron half-mounting bars, raise the workpiece by 28 mm in order to perform through-hole machining.

With M12 fixing screws

Half-mounting bar 225 mm 09-045

For clamping elements (09-070) or stops (09-120 to 09-135)



Mounted with 2 x M 12 screws and special washer

Half-mounting bar 225 mm 09-046

without holes

For clamping elements (09-070)



Locators - Fixing
page 27

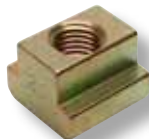

Anti-vibration support



Place the Lifter under the workpiece and turn the adjustment pin until contact is made



These locators enable quick and precise alignment of mounting bars and supports..

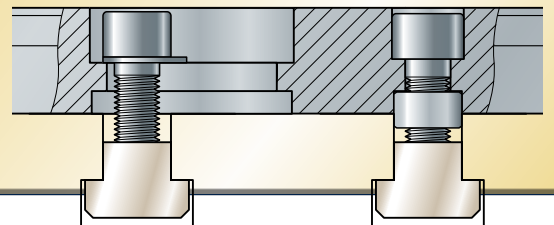

Anti-vibration support (Lifter)

28 mm workpiece support preventing workpiece deformation and vibration during machining. Supporting force 1200 N

Lifter

09-060

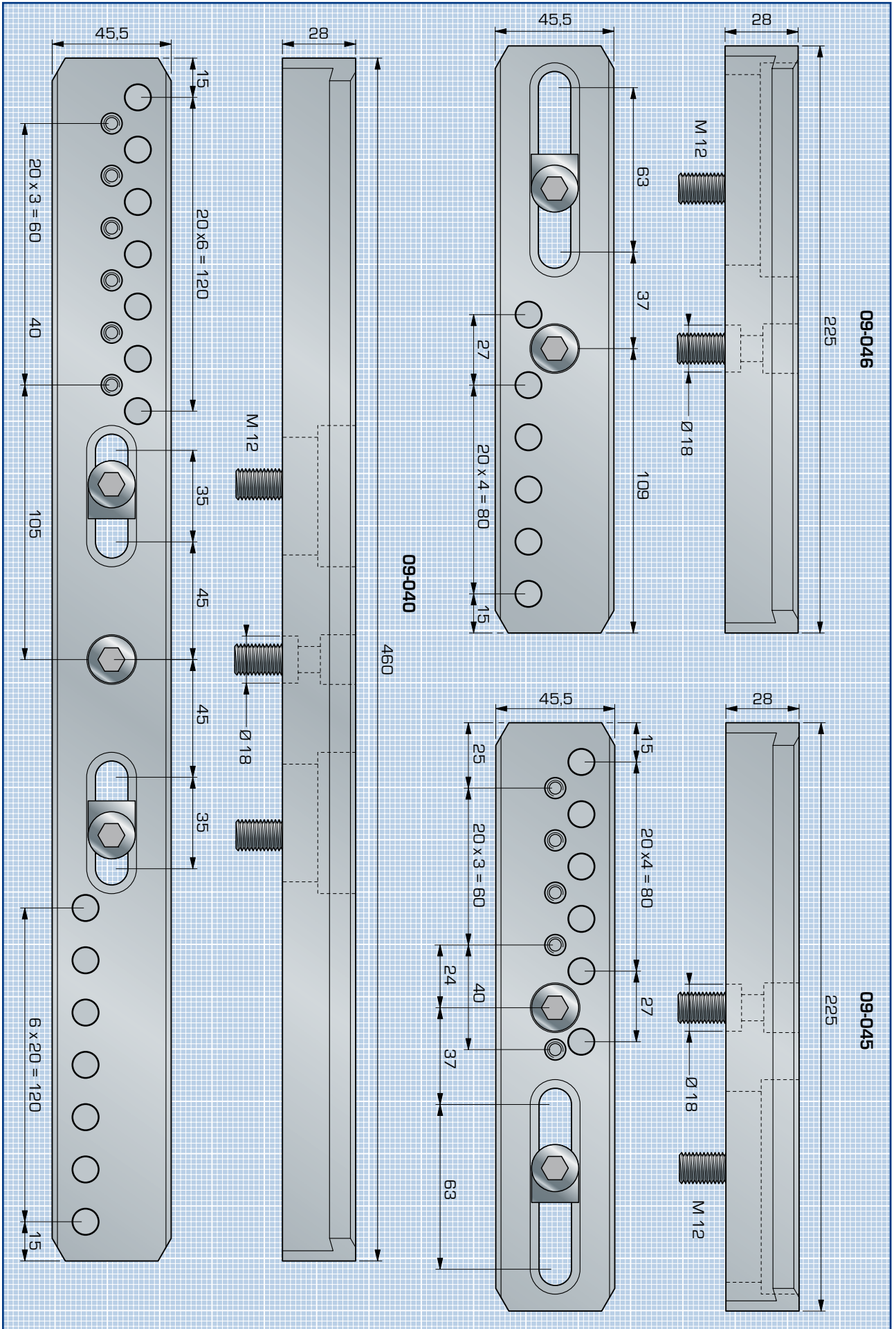

6500 Newton

6500 Newton Clamping equipment for Machining set-ups

With fixing screws and Clamping key

Ref.

09-490

including :

- ① 2 Mini driving clamps 09-110
- ② 1 Mini fixed clamp / locator 09-150
(with screw and index)

6500 N.



Specific Machining set-ups



Clamping force : **6500 N.**
Clamping torque : 6 N.m
Clamping range : 7 mm

Clamping elements

Ref.

Made of spring steel

With fixing screws and Clamping key

Low mini driving clamp
clamping height 2,5 mm
for low workpieces

09-111

Standard mini driving clamp
clamping height 6 mm

09-110



KOPAL



Fixed clamps (Stops)

Ref.

Reversible clamps made of spring steel
for clamping of facing workpieces

With clamping screw and positioning index

Low mini reversible clamp/locator
clamping height 2,5 mm
für Teile mit geringer Dicke

09-152

Standard mini reversible clamp/locator
clamping height 6 mm

09-150

Double ended mini reversible clamp/locator
clamping height 6 mm

09-151

With two rigid supports - can be used on its own for
small workpieces of max. 40mm in width

Clamping heights

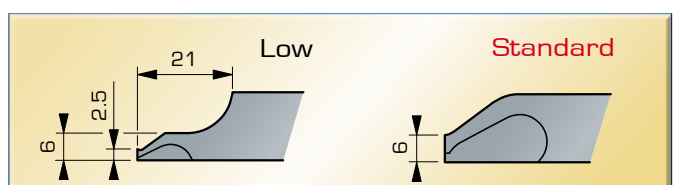

Machining assembly is carried out according to workpiece dimensions



Machining of an aluminium plate with mini driving clamps on special supports

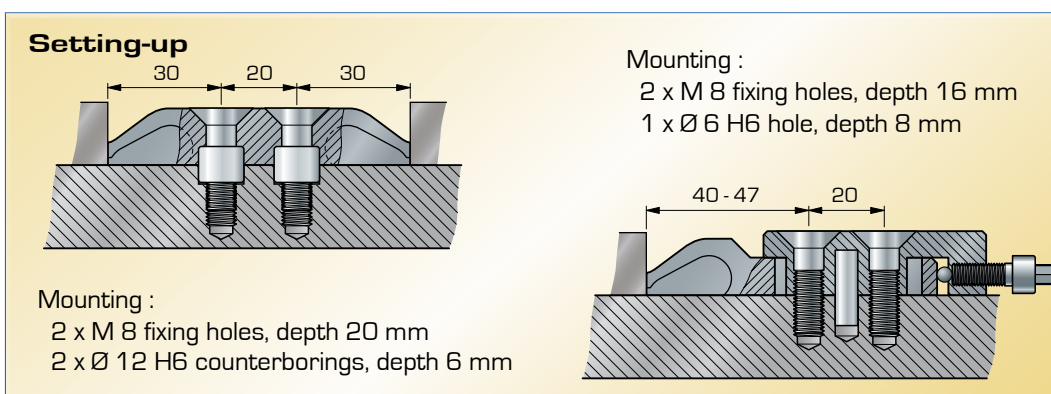
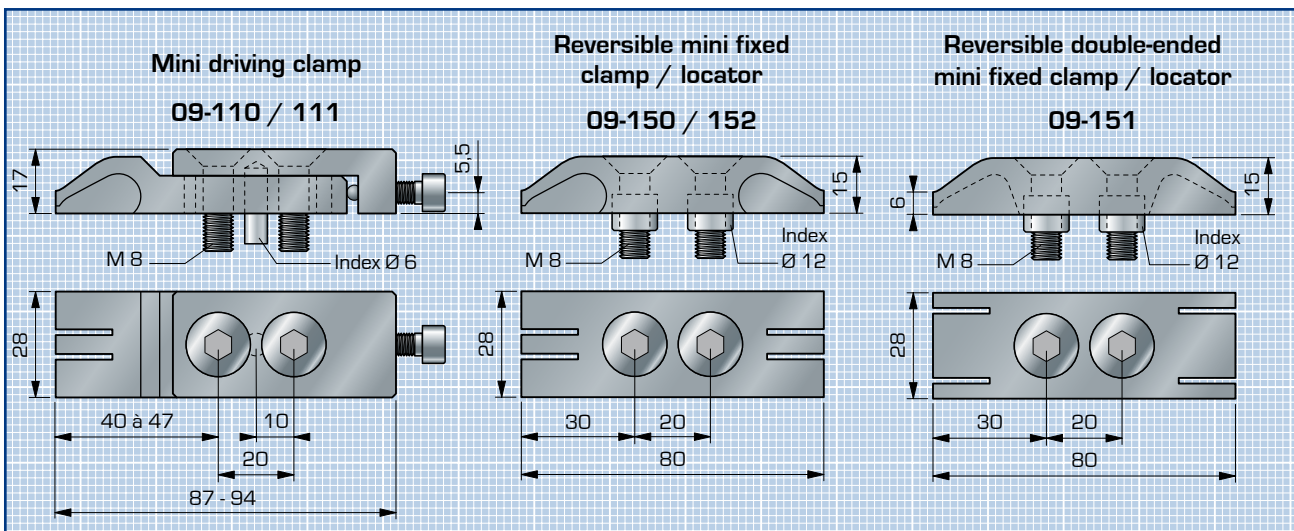
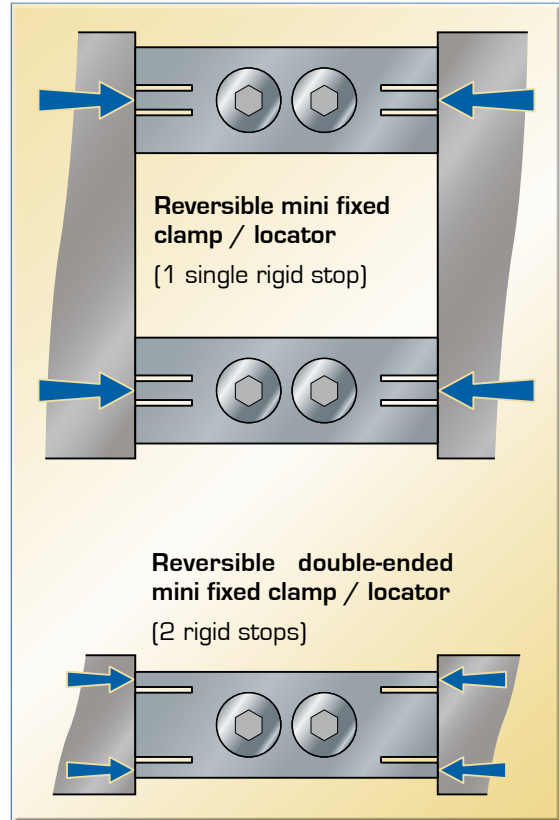

4000 Newton

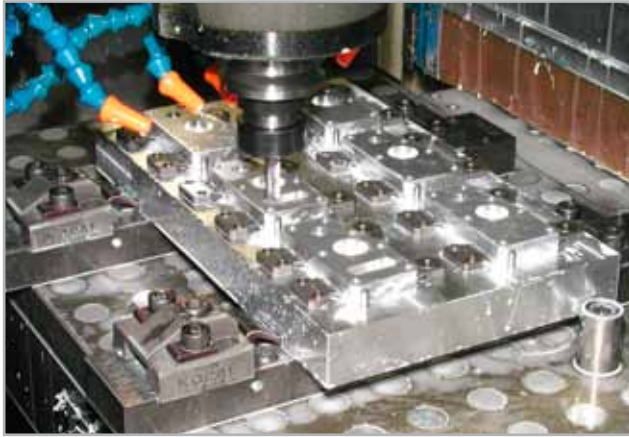

Mini-Clamp

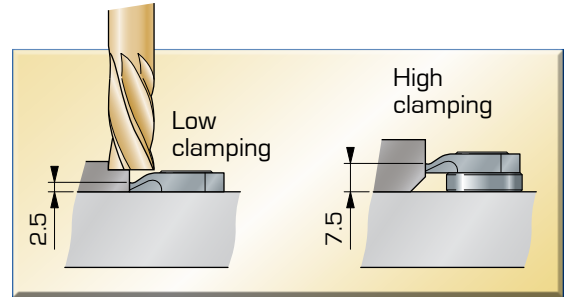

- Compact
- Ultra-quick clamping
- High clamping power
- Cylindrical parts

4000 N.

KOPAL

Mini-clamping for specific machining set-ups with eccentric

	Ref.
① Pillar-type moving clamp/locator clamping height 2,5 mm	25-210
② Raised pillar-type moving clamp/locator clamping height 7,5 mm	25-215
Clamping key (sold separately) T-shaped, 4mm hexagonal	25-980

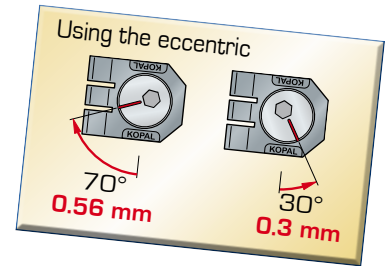

Fast 1/4 turn clamping



i The moving clamp/locators pivot around an eccentric axis, which carries out the clamping. They can clamp in all directions..

*Clamp (1 single rigid stop)
Firmly presses the
workpiece onto the stops.*

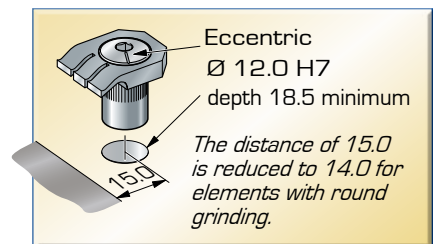
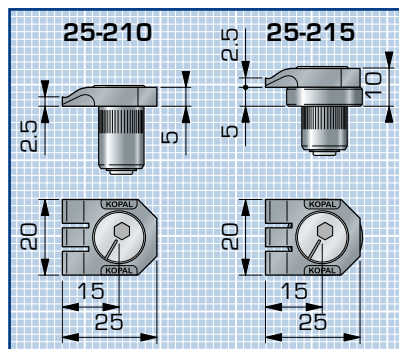
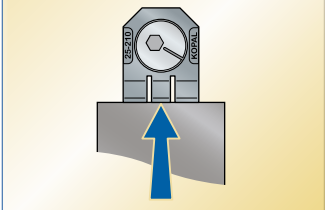

4000 Newton

Fixed stop

- | | Ref. |
|--|--------|
| 1 Fixed clamp/locator
clamping height 2,5 mm | 25-105 |
| 2 Double fixed clamp/locator
clamping height 2,5 mm | 25-110 |
| 3 Raised fixed clamp / locator
clamping height 7,5 mm | 25-115 |
| 4 Raised double
fixed clamp / locator
clamping height 7,5 mm | 25-120 |



With fixing screws

Ground fixed stops are fixed in position with special screws ensuring high precision mounting.

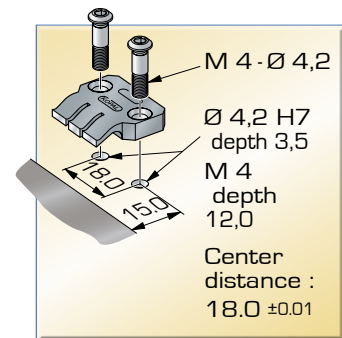
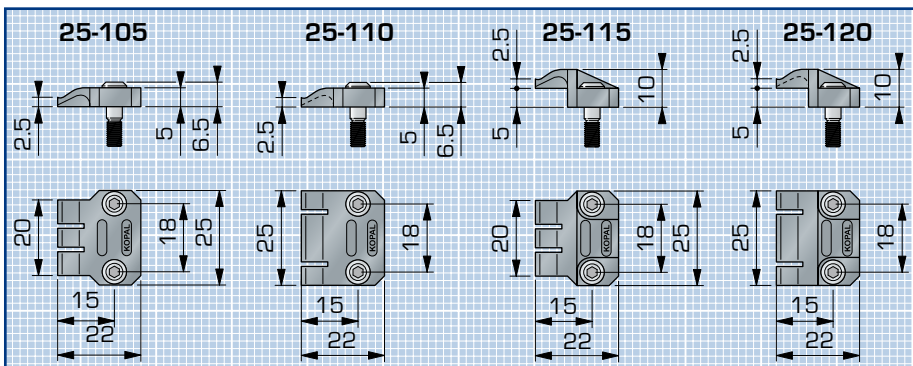
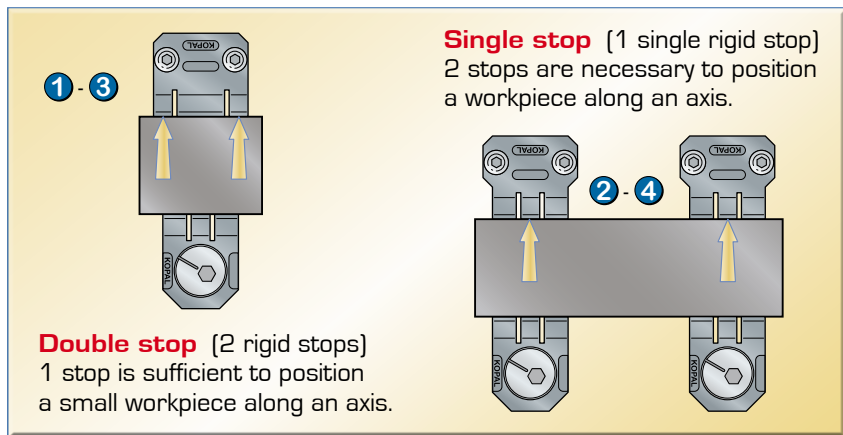

Swivel stop

- | | Ref. |
|---|--------|
| 5 Swivel fixed clamp/locator
clamping height 2,5 mm | 25-125 |
| 6 Raised swivel fixed clamp / locator
clamping height 7,5 mm | 25-130 |

With fixing screw

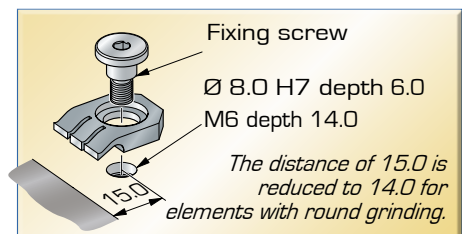
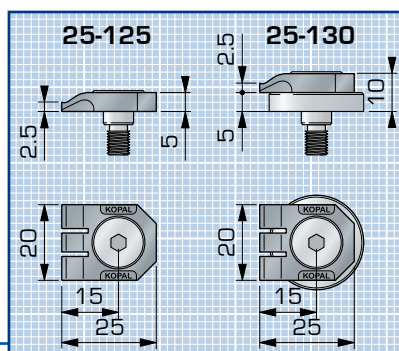
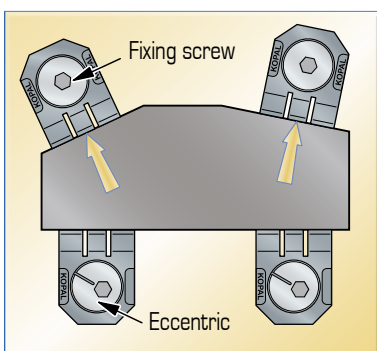

4000 Newton

Clamp-slot for T-slot tables

KOPAL

Clamp-slot

Equipment includes :

1 clamping element

1 stop element

for slots :	A	B	Ref.
10 mm	46	18	25-260
12 mm	48	18	25-262
14 mm	52	22	25-264
16 mm	48	25	25-266
18 mm	48	25	25-268

Clamping key

25-980

T-shaped, 4mm hexagonal

Clamping force : **4000 Newton**
 Clamping torque : 9 N.m
 Clamping range : **0.86**



Clamping key
sold separately



Fast 1/4 turn
clamping

HORIZONTAL CLAMPING

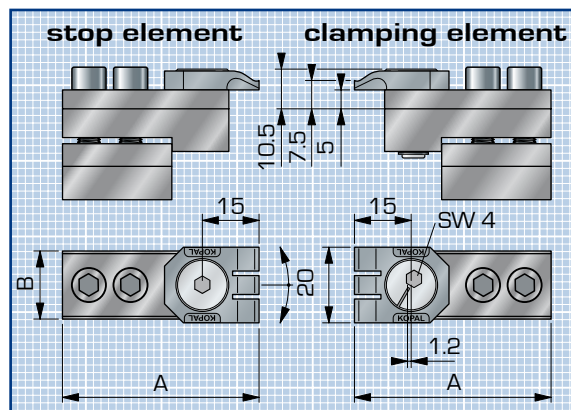
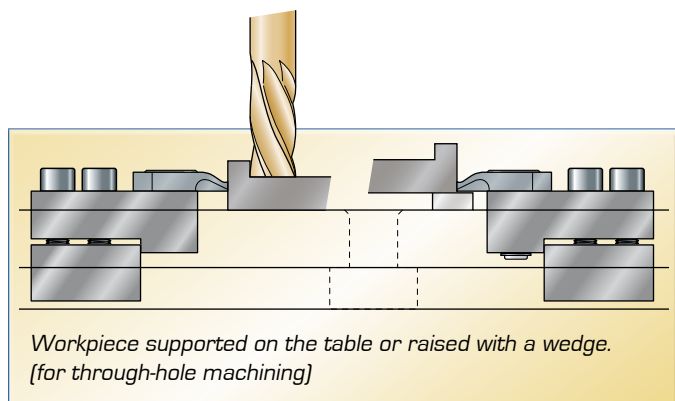
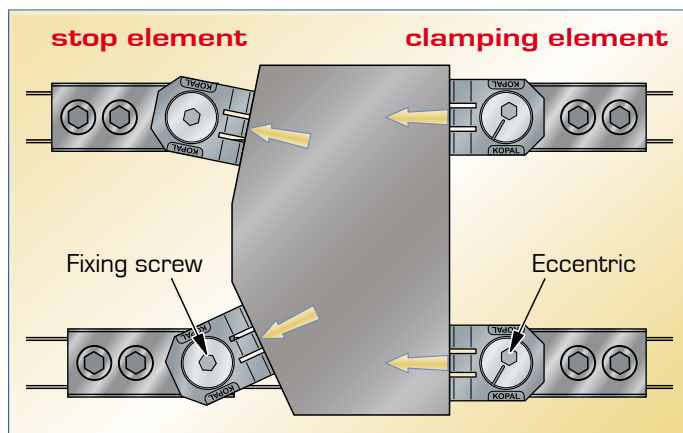



Vertical clamping System KOPAL®

KOPAL®



KOPAL System	
Principle - Presentation	40
Boxed sets	41
Electro-erosion Clamping	42
Piccolo 6500 N	43
Monobloc 16000 N	44 - 45
Bloc bride 16000 N	46 - 47
Duo 11000 N	48 - 49
Clamping accessories	50 - 51
Big block 40000 N	52 - 54
Spare parts	55
Chain Clamping	
16000 N	56 - 57
50000 N	58
Workpiece Support	59
Other clamping	
Terrific 11000 N	60 - 61
Maxibloc 35000 N	62 - 63
Blocapress 50000 N	64
Fixing, T-nuts, screws	65

Presentation

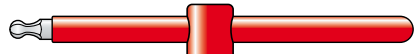

Clamping with vertical pressure System KOPAL®

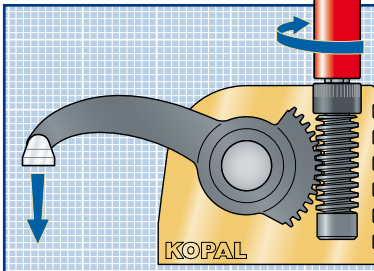

- This system requires neither riser block nor adjustment and clamping height can be adjusted at any time with a simple turn of the clamping key while maintaining clamping force.
- It can be used with all types of machine-tool tables, electrical discharge machines and modular or T-slot-type press tables (depending on model).
- The clamps are "monobloc" type, ensuring stable and robust mounting and rapid setting-up and dismantling, with a clamping force of up to 50000 N.

Light machining
EDM clamping
6500 N.
page 42



Clamping and lifting
11000 N.
page 48



All machining
operations
16000 N.
page 44



Heavy machining
40000 N.
page 52



Clamping
accessories
page 50



Repetitive machining
11000 N.
page 60



Chain clamping
16000 N.
page 56

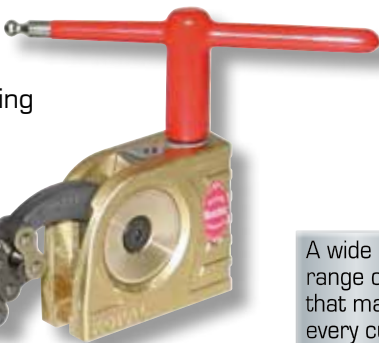

A wide and balanced
range of clamps
that matches
every customer's
requirements

Heavy machining
35000 N.
page 62



Chain clamping
50000 N.
page 58



Heavy machining
Press clamping
50000 N.
page 64



VERTICAL CLAMPING

Boxed sets

Piccolo	Clamping Reach Clamping Height*		Ref.
Clamping Force	54	118 mm	07-100
6500 N.			

(* with a riser block)

Contents :

- ① 2 Piccolo
- ② 2 x 60 mm riser blocks
- ③ 1 clamping key
- ④ 1 extra long arm
- ⑤ 1 set of 4 different shaped swivel shoes
- ⑥ 4 x M 8 screws
- ⑦ 6 M 8 T-nuts with spring
(2 for each 12, 14 & 16 mm slot)



KOPAL



Monobloc	Clamping Reach Clamping Height*		Ref.
Clamping Force	33	154 mm	06-110
16000 N.	61	176 mm	06-100
12000 N.			

(* with a riser block)

Contents :

- ① 2 Monobloc
- ② 2 x 74mm riser blocks
- ③ 1 clamping key
- ④ 1 extra long arm
- ⑤ 4 x M 10 screws
- ⑥ 6 x M 10 T-nuts with spring
(2 for each 14, 16 & 18mm slot)

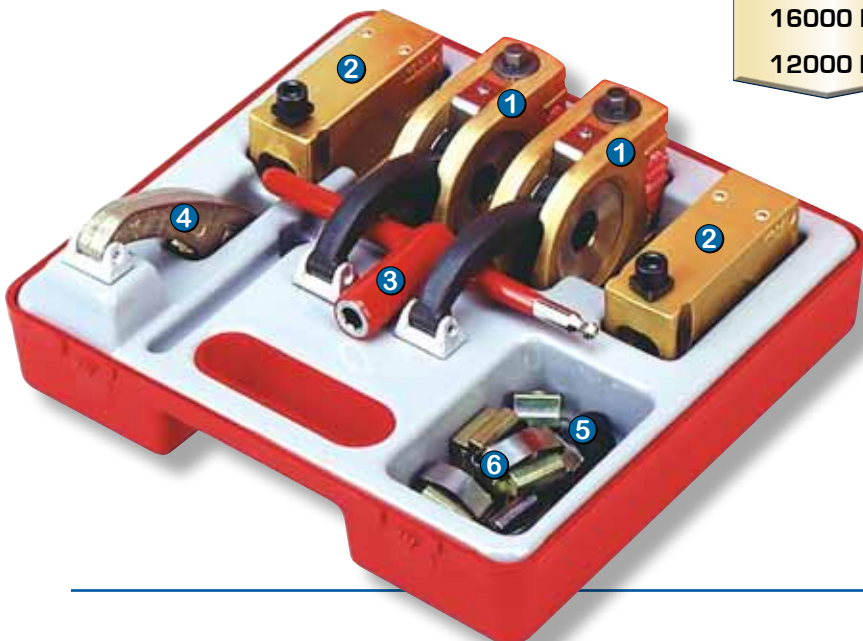

VERTICAL CLAMPING

Piccolo EDM

- Quick assembly
- Simple cleaning mechanism
- Large capacity



Piccolo	Clamping Force	Clamping		Clamp with clamping key Ref.	Clamp without clamping key Ref.
		Reach	Height		
Short arm	6000 N.	54	-15 to 58 mm	07-022	07-016
Long arm	4000 N.	100	-40 to 90 mm	07-023	07-018

3 m/kg maximum clamping torque .

aluminium bronze body, aluminium swivel shoe, steel arm.

With clamping key and M8 x 30 clamping screw 

Nickel-plated clamping key (standard)

07-180



The only rapid clamp specially designed for electrical discharge machining



The body has a large opening to ensure the free flow of fluid. The operating mechanism is designed to avoid jamming. The clamp can be removed quickly without a tool, thus simplifying clamp cleaning operations.



Assembly of standard and EDM Piccolo models

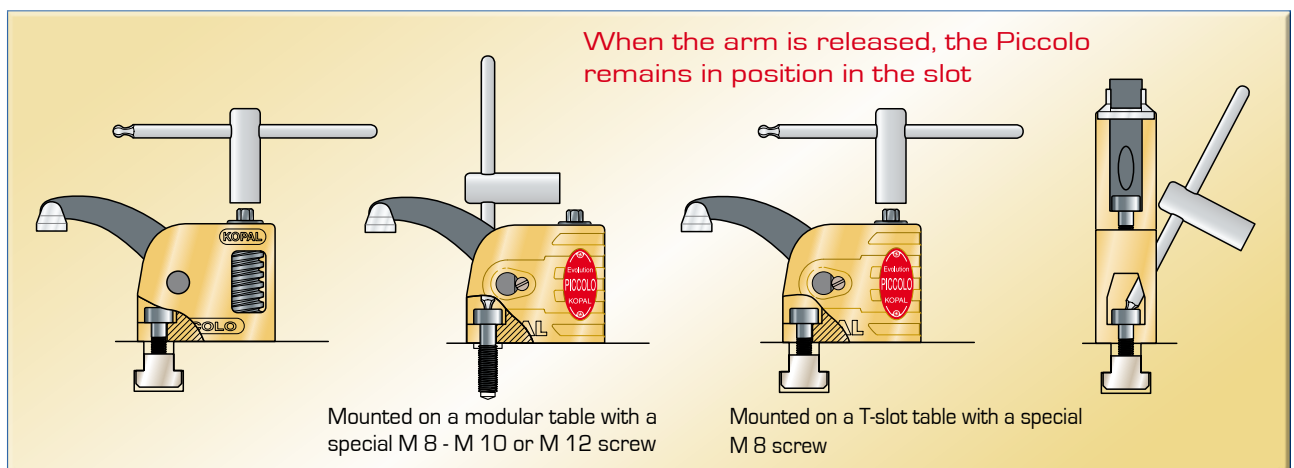

Piccolo 6500 N.

- Numerous accessories
- Powerful clamping
- Compact



Piccolo	Clamping Force	Clamping Reach	Clamping Height
Short arm	6500 N.	54	-15 to 58
Long arm	4200 N.	100	-40 to 90

Clamp with clamping key Ref.
07-020
07-025

Clamp without clamping key Ref.
07-021
07-026

3 m/kg maximum clamping torque .

aluminium bronze body, aluminium swivel shoe, steel arm.

With clamping key and M8 x 30 clamping screw

Nickel-plated clamping key (standard)

07-180

T-slot tables
Modular tables

6500 N.
3 m/kg

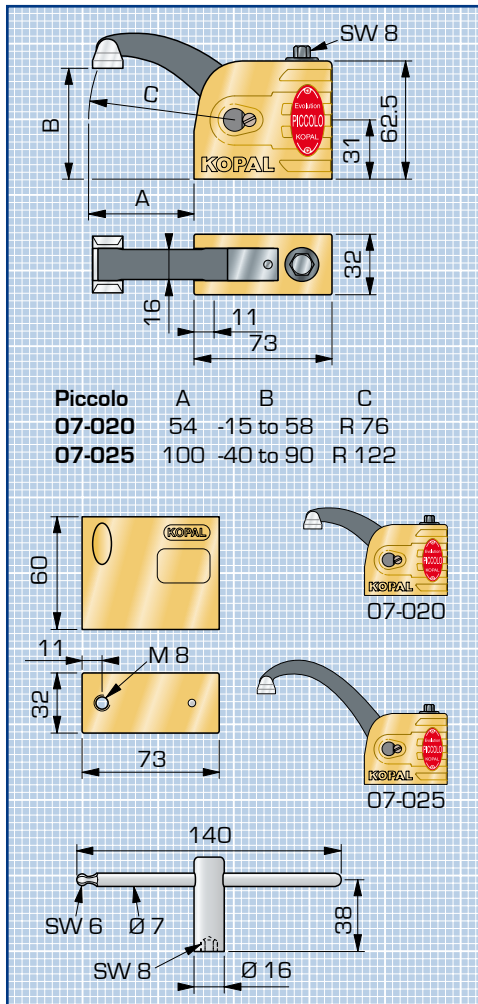

Particularly in drilling applications, you will appreciate the practicality of a clamp that provides exceptional power for such a compact size.

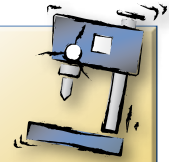

Clamping screws Ref.

M 8 x 30 mm	07-720
M 10 x 35 mm	07-730
M 12 x 35 mm	07-735



Riser block 07-030

These Aluminium 60 mm riser blocks can be stacked in order to clamp very high workpieces. Supplied with clamping screw.



KOPAL

Piccolo Boxed set	Clamping Force	Clamping Reach	Clamping Height*	Ref.
Short arm	6500 N.	54	0 to 118	07-100

(* with a riser block)



M 8 T-nuts
Slot size Ref.

10 mm	90-050
12 mm	90-055
14 mm	90-060
16 mm	90-065
18 mm	90-070

Monobloc 16000 N.

- Multi-purpose
- Ultra-quick clamping
- New ergonomic key
- High clamping power



The clamp is mounted using screws and remains in a fixed position



Monobloc (clamping arm)	Clamping Force	Clamping Reach	Clamping Height	Clamp with clamping key Ref.	Clamp without clamping key Ref.
Short arm	16000 N.	33	0 to 80	06-020	06-022
Long arm	12000 N.	61	- 8 to 102	06-030	06-032
XXL arm	800 N.	132	- 43 to 155	06-035	06-036



8 m/kg maximum clamping torque .

Aluminium swivel shoe and body, steel arm.

Fixing screws supplied separately

Coated clamping key, height 58 mm (standard)

06-160

Nickel-plated clamping key, height 88mm (with XXL arm)

06-325

KOPAL

Why use the Monobloc
Tables with T-slots
Tables with tapped holes
When the arm released, the Monobloc remains fixed in position in the slot

- 1 Slide the T-nut and the screw into the slot.
- 2 Position and tighten the clamp onto the table using the clamping key provided.
- 3 Clamp the workpiece using the same key
- 4 Proceed with machining

Mounted on modular table with a special screw :
M10 - M 12 - M 14 or M 16

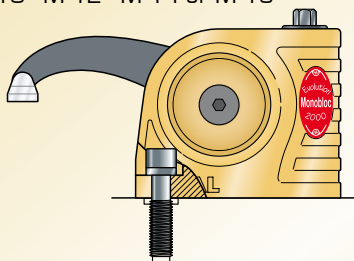

Mounted on T-slot table with special M 10 screw

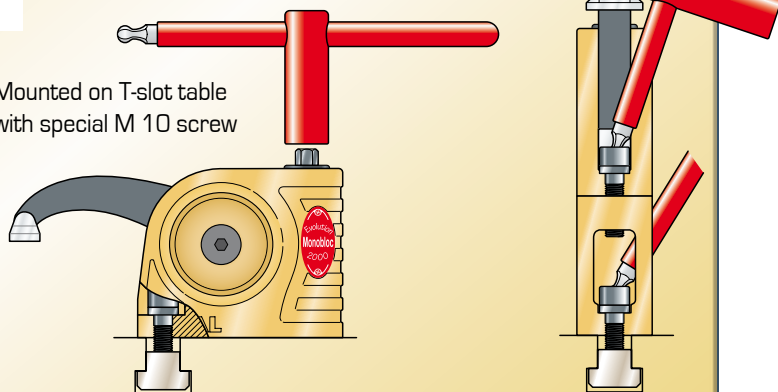

Monobloc Box set	Clamping Force	Clamping Reach	Clamping Height*	Ref.
Short arm	16000 N.	33	0 to 154 mm	06-110
Long arm	12000 N.	61	- 8 to 176 mm	06-100

(* with riser block) **Composition page 41**



Monobloc 16000 N.

Monobloc fittings

	Type	Ref.
for slot sizes		
M 10 x 35	12 and 14 mm	06-080
M 10 x 40	16 and 18 mm	06-085
M 10 x 45	20 and 22 mm	06-090
for tapped holes		
M 12 x 40	M 12	06-065
M 14 x 45	M 14	06-070
M 16 x 45	M 16	06-075



Aluminium riser block

	Height	Ref.
These riser blocks can be stacked in order to clamp very high workpieces.	74 mm	06-050
Supplied with M 10 x 35 mm clamping screw		

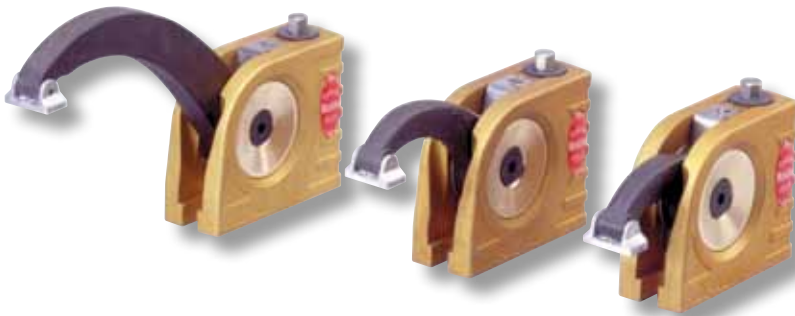

M 10 T-nuts

Slot size	Ref.
12 mm	90-100
14 mm	90-105
16 mm	90-110
18 mm	90-115
20 mm	90-120
22 mm	90-125
24 mm	90-130
28 mm	90-135

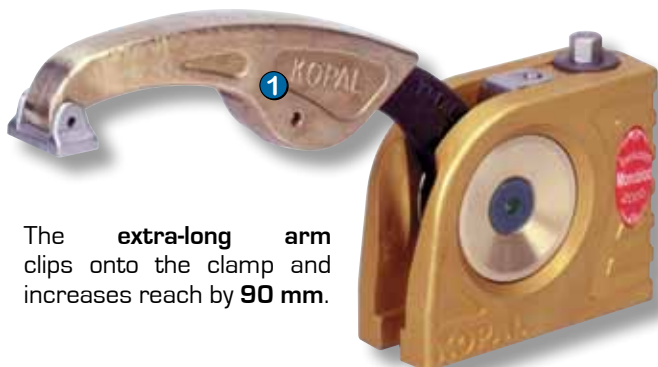
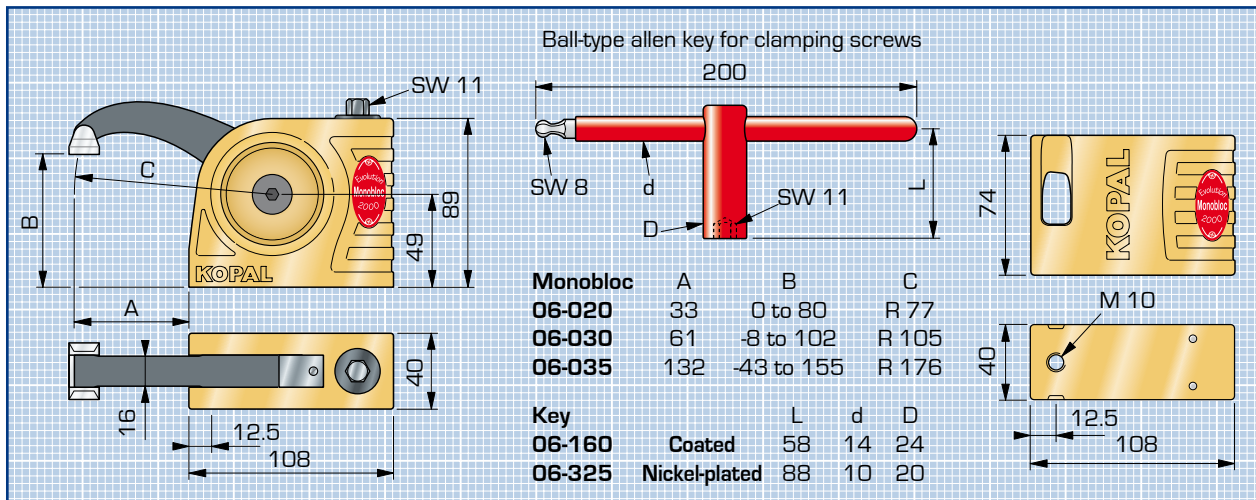

The extra-long arm clips onto the clamp and increases reach by 90 mm.

Accessories

	Ref.
1 Extra-long arm	05-140
2 Set of 4 different shaped aluminium swivel shoes	06-150

Accessories on page 50

Swivel shoe N°2
Ref. 06-802



Bloc Bride 16000 N.

- Multi-purpose
- Ultra-quick assembly and workpiece changeover
- Numerous accessories



Record installation and clamping time

Bloc Bride (clamping arm)	Clamping Force	Reach	Clamping Height	Clamp with clamping key Ref.	Clamp without clamping key Ref.
Short arm	16000 N.	1.3"	0 to 80 mm	05-020	05-021
Long arm	12000 N.	2.4"	- 8 to 102 mm	05-030	05-031
XXL arm	8000 N.	5.196"	- 43 to 155 mm	05-035	05-036

16000 N.
8 m/kg

8 m/kg maximum clamping torque .

Aluminium swivel shoe and body, steel arm.

Remember to order the mounting set (T-nut and screws) corresponding to the width of your machine's slots 

Coated clamping key, height 58 mm (standard)

05-180

Nickel-plated clamping key, height 88 mm (with XXL arm)

06-325

Safe clamping is an important factor in user safety

Why choose the Bloc Bride
For tables with T-slots
For boring / milling machines
When the arm is released, the Bloc Bride slides in the slot.

- 1 Slide the clamp into the slot, in position for clamping the workpiece.
- 2 Clamp the workpiece directly using the clamping key provided.
- 3 Proceed with machining.

Assemble onto the sliding component with a swivel seat (09-456)

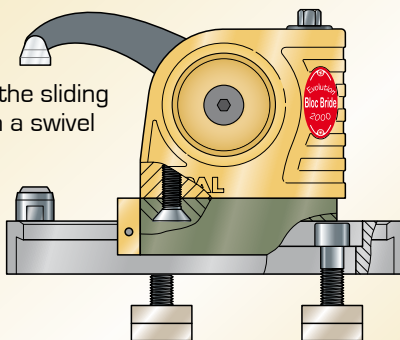

Adjust the position of the clamp or riser block T-nut in relation to slot height, leaving a minimum clearance height

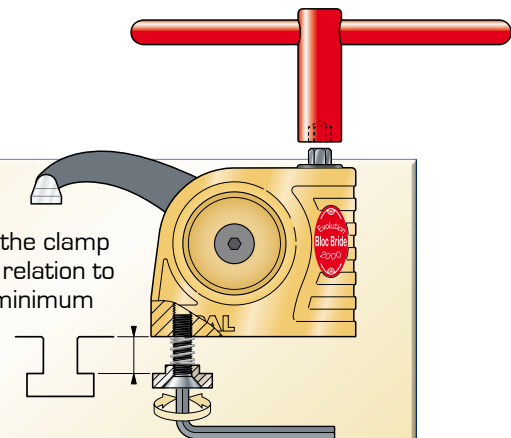

Extend clamping reach by 90 mm with the extra-long arm (05-140)

Mounting with riser block (06-050)

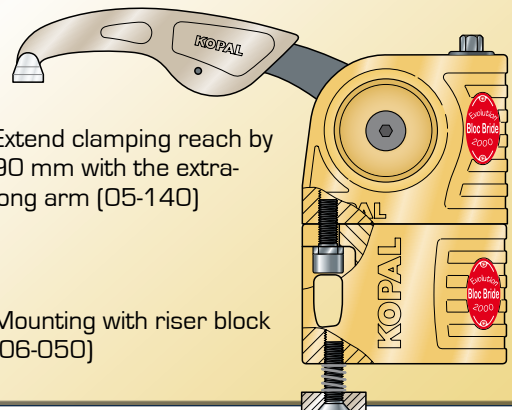

Bloc Bride 16000 N.

Bloc Bride Mounting set Ref.

Special T-nuts, TF screws and springs

For slot sizes :

width 12 mm	05-200
width 14 mm	05-205
width 16 mm	05-210
width 18 mm	05-215
width 20 mm	05-220
width 22 mm	05-225



74 mm riser block Ref.

in Aluminium

06-050

These riser blocks can be stacked in order to clamp very high workpieces. Supplied with clamping screw. Use the clamp's special T-nut

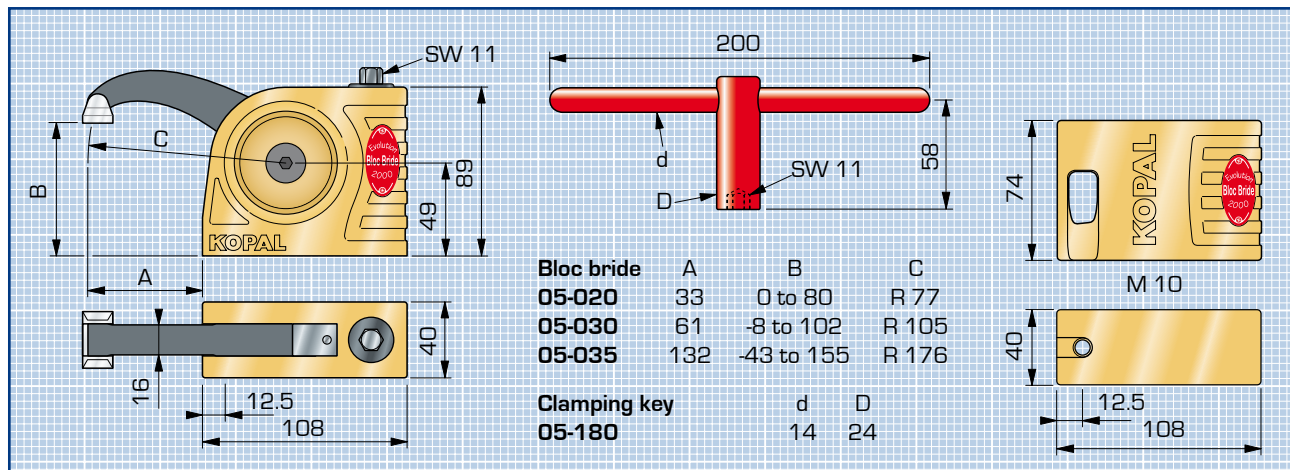
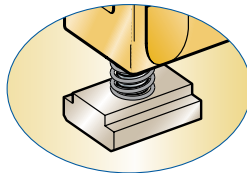

Accessories

Ref.

- 1 Sliding element 09-456
- 2 Set of 4 different shaped aluminium swivel shoes 06-150

Accessories on page 50



Swivel shoe N°4
Ref. 06-804



Duo 11000 N.

- Adjustable clamping range
- Lifting and Clamping
- 2 interchangeable arms of different shapes



DUO	Clamping Force	Reach	Clamping Height	Lifting Height	Clamp with clamping key Ref.	Clamp without clamping key Ref.
	11000 N.	46 to 91	0 to 129	4 to 142	21-020	21-022

8 m/kg maximum clamping torque .

Aluminium swivel shoe and body, steel arm.

With 2 arms, 1 clamping key and 1 clamping screw

74 mm aluminium riser block

Coated clamping key, height 58 mm [standard]

06-050

06-160



- Slide the T-nut and screw into the slot.
- Position the clamp and clamp it onto the table using the clamping key provided.
- Clamp the workpiece using the same key.
- Proceed with machining.

When the arm released, the Monobloc remains fixed in position in the slot

Why use the Duo
Tables with T-slots
Tables with tapped holes

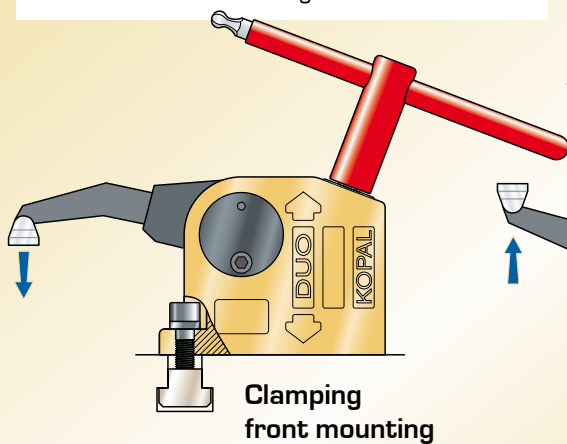

Mounting on T-slot table with special M10 screw

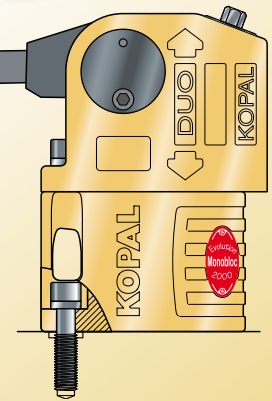
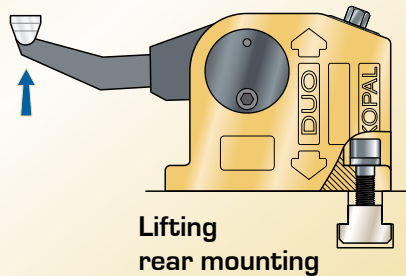

Mounting on modular table with special screw:
M10 - M 12 - M 14 - M 16

11000 N.
8 m/kg

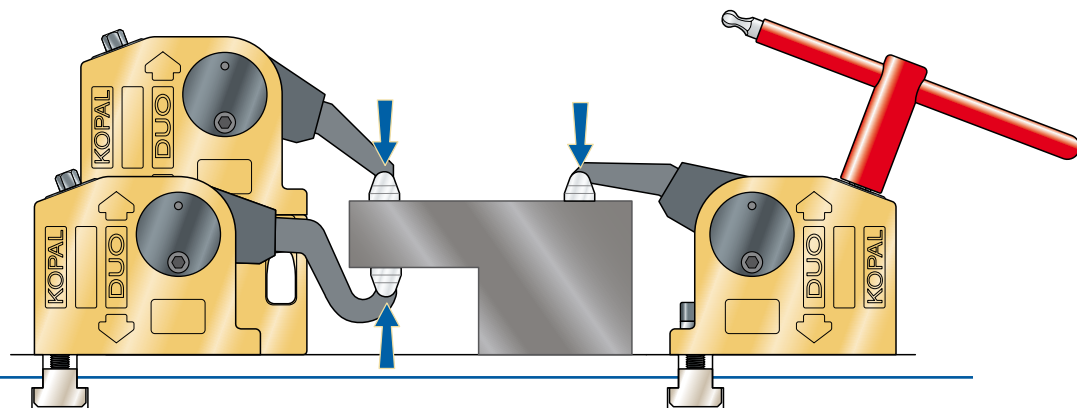

48 KOPAL

VERTICAL CLAMPING

Duo 11000 N.

DUO fittings

	Type	Ref.
for slot sizes		
M 10 x 35	12 and 14 mm	06-080
M 10 x 40	16 and 18 mm	06-085
M 10 x 45	20 and 22 mm	06-090
for tapped holes		
M 12 x 40	M 12	06-065
M 14 x 45	M 14	06-070
M 16 x 45	M 16	06-075



KOPAL

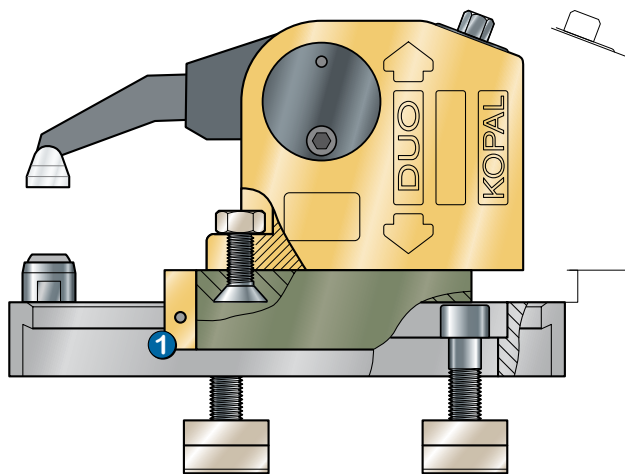
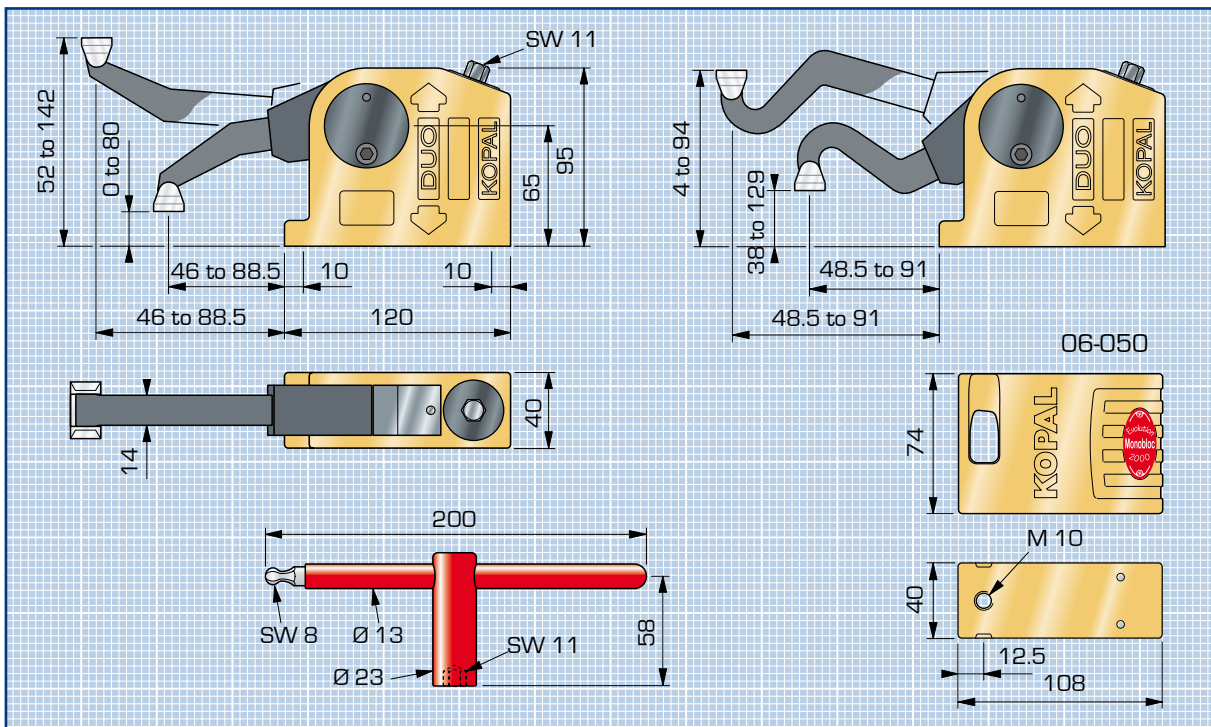

Sliding element
allows quick retraction of clamp
(09-456).

Accessories

	Ref.
1 Sliding element	09-456
2 Set of 4 different shaped aluminium swivel shoes	06-150

Accessories on
page 50

M 10 T-nuts

Slot size	Ref.
12 mm	90-100
14 mm	90-105
16 mm	90-110
18 mm	90-115
20 mm	90-120
22 mm	90-125
24 mm	90-130
28 mm	90-135



KOPAL 49

VERTICAL CLAMPING

Accessories

Aluminium swivel shoes	Ref.
① Shoe N° 1 Standard by 5 pieces	05-565 06-152
② Shoe N° 2 Longitudinal	06-802
③ Shoe N° 3 Transverse	06-803
④ Shoe N° 4 Transverse V	06-804
⑤ Shoe N° 5 Longitudinal V	06-805
Set of 4 different shaped shoes N°2, N°3, N°4, N°5	06-150

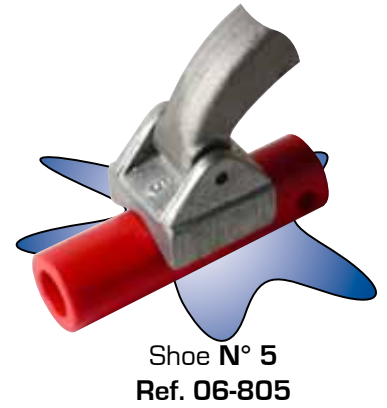

KOPAL



Same accessories for Piccolo, Monobloc, Bloc Bride and Duo ranges

Extra-long arm	Ref.
Retractable arm Increases clamping reach by 90 mm. Supply with N° 1 shoe.	05-140

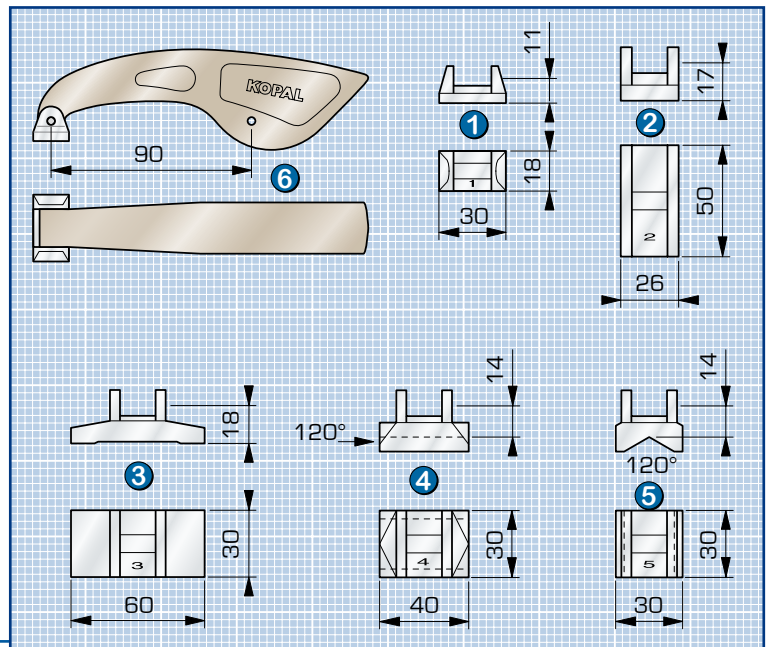

Accessories



KOPAL

for Piccolo, Monobloc,
Bloc Bride and Duo



Sliding element

Ref.

Retracts the clamp quickly

09-456

Mounting with 2 x M 12 screws.

Includes :

Support

05-150

- 1 bar (made in cast iron)
- 2 swivel seat
- 3 adjustable stop

Slide

09-195

- 4 made in Aluminium
- With screw for mounting the clamp

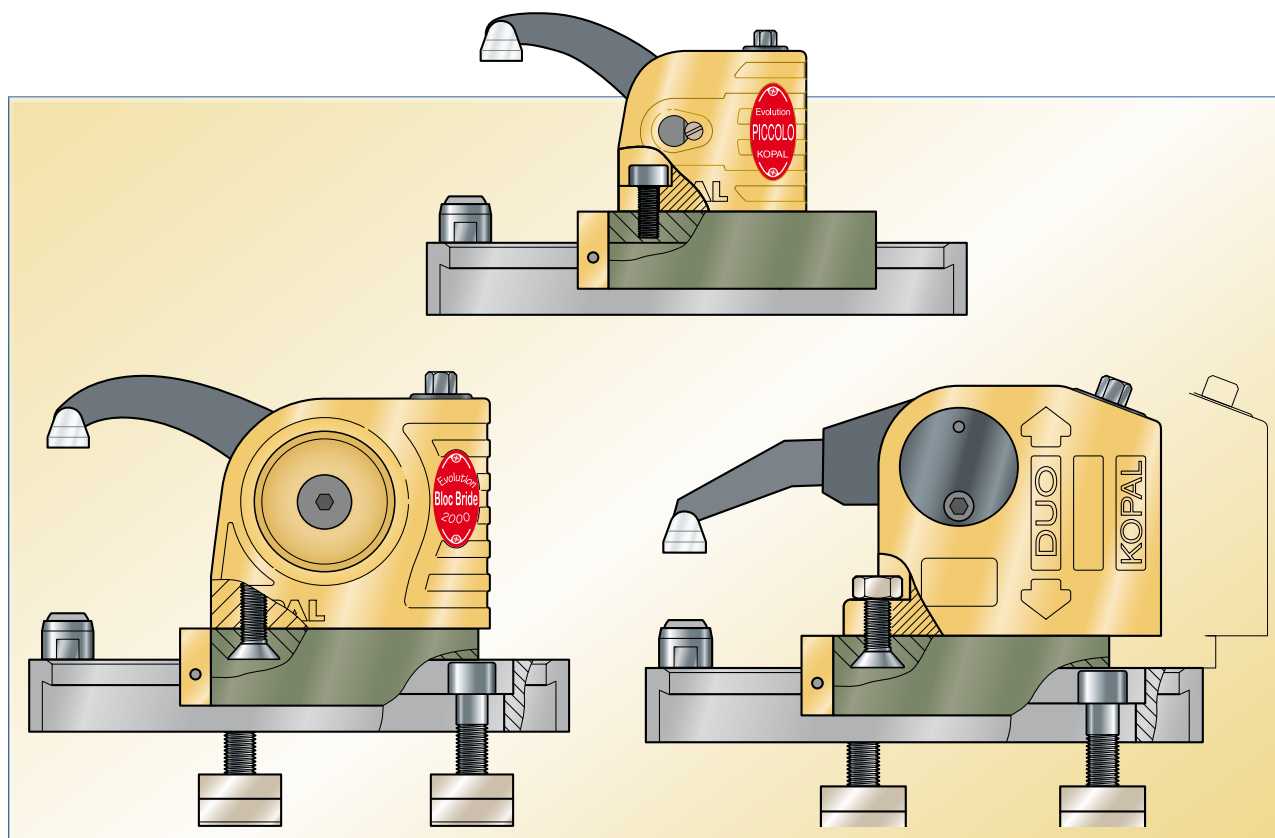
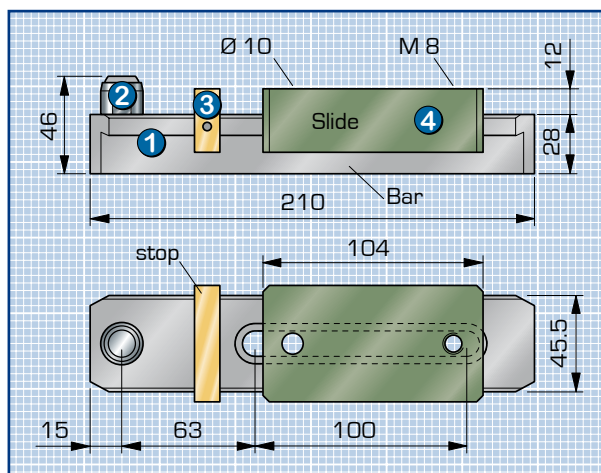

Big Block 40000 N.

- Very high clamping height
 - 4 different models
- Quick assembly**



Big Block

Clamping Force	Reach	Clamping Height
40000 N.	50	12 to 80 mm
28000 N.	95	- 12 to 100 mm
20000 N.	145	- 18 to 135 mm
14000 N.	245	- 50 to 155 mm

Clamp with clamping key
Ref.

08-020
08-030
08-035
08-038

Clamp without clamping key
Ref.

08-021
08-031
08-036
08-039

40000 N.
7 m/kg

7 m/kg maximum clamping torque .

Aluminium swivel shoe and body, steel arm.

With clamping key, swivel shoe and adaptor

Clamping key

08-160

Use : T-slot tables
Modular tables

When the workpiece is released, the Big-block can either remain fixed in the slot, or slide in the slot.

Mounting directly on the table (without base or riser block), with a stud with cylinder (sold separately)

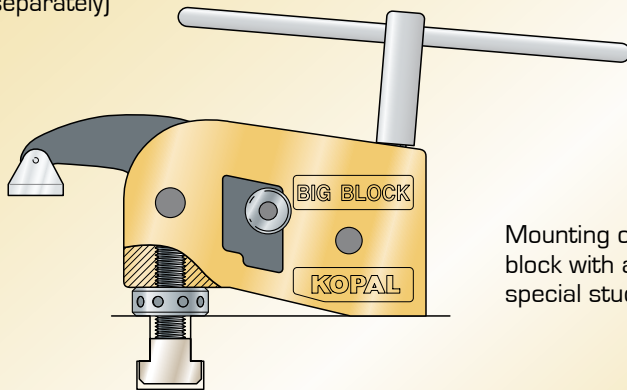

Quick mounting and dismounting

Mounting on base and riser block with adaptor and special stud

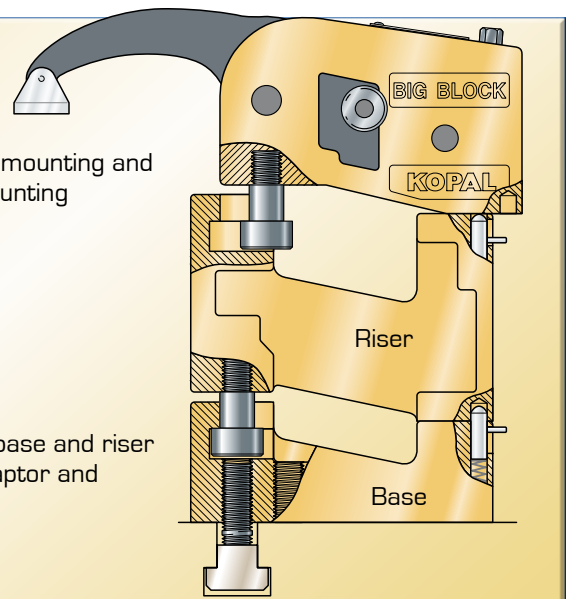

The arm can be indexed in 5 positions for quick clamping height adjustment.

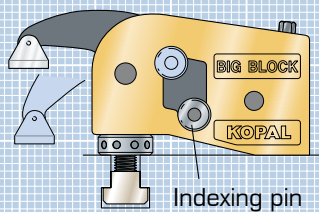

Big Block 40000 N.

Studs with cylinder

Ref.

For mounting the Big Block directly onto the table

V2-C1	M 14 x 62 mm	08-060
V2-C1	M 14 x 82 mm	08-070
V2-C2	M 16 x 70 mm	08-080
V2-C2	M 16 x 80 mm	08-090



Special studs

For mounting the base on the table

V2-1	M 14 x 60 mm	08-100
V2-1	M 14 x 80 mm	08-110
V2-2	M 16 x 65 mm	08-120
V2-2	M 16 x 85 mm	08-130

Riser block N°1 55 mm 08-045

Riser block N°2 110 mm 08-050

Riser block N°3 330 mm 08-055

With an adaptor



55 mm Base

08-040

made in Aluminium

With an M 16 x 65 mm mounting stud

Swivel shoes

Standard aluminium shoe

08-330



T-nuts	M 14	M 16
Slot size	Ref.	Ref.
16 mm	90-200	
18 mm	90-205	90-250
20 mm	90-210	90-255
22 mm	90-215	90-260
24 mm	90-220	90-265
28 mm	90-225	90-270

KOPAL

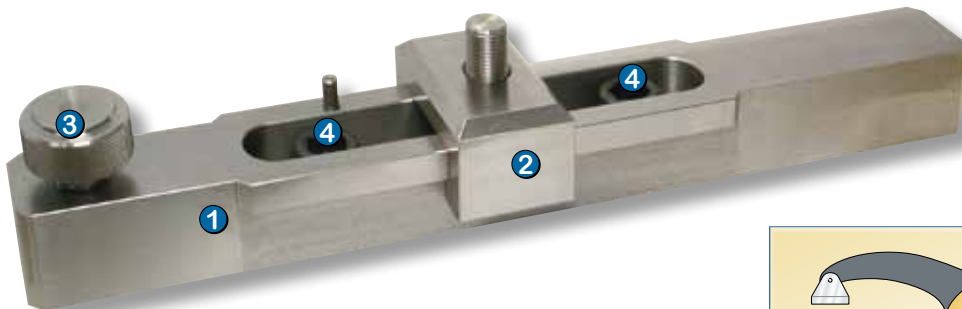

Sliding equipment

Ref.

08-180

- ① 1 bar
- ② 1 slide
- ③ 1 adjustable workpiece support
- ④ 2 M16 mounting screws

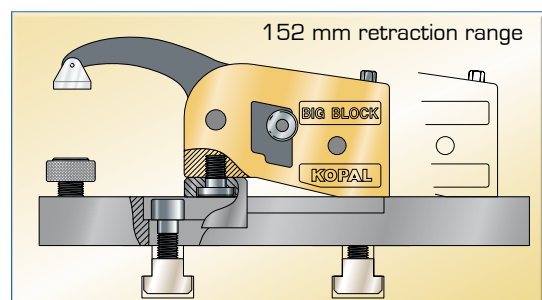

Big Block 40000 N.

The range

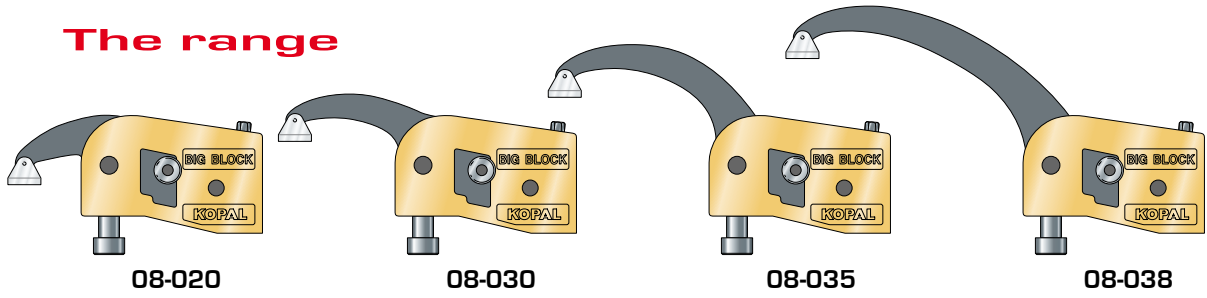

Big Block	A	B	C
08-020	50	12 to 80	R 75
08-030	95	-12 to 100	R 120
08-035	145	-18 to 135	R 170
08-038	245	-50 to 155	R 270

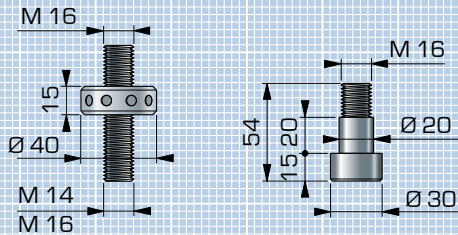
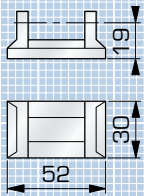

Riser blocks	A
08-045	55
08-050	110
08-055	330

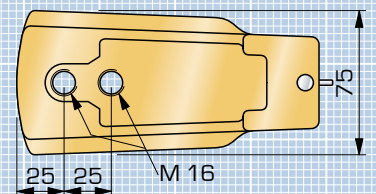
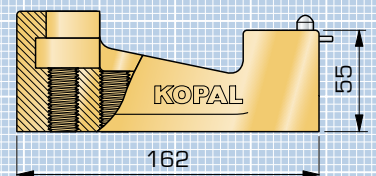
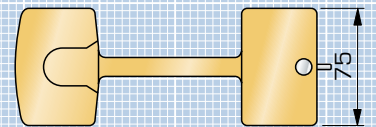
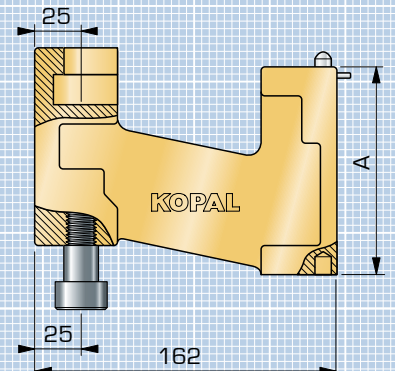
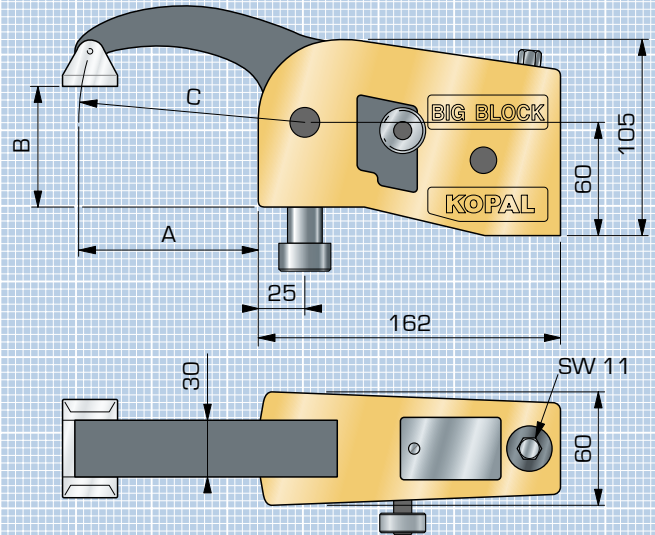
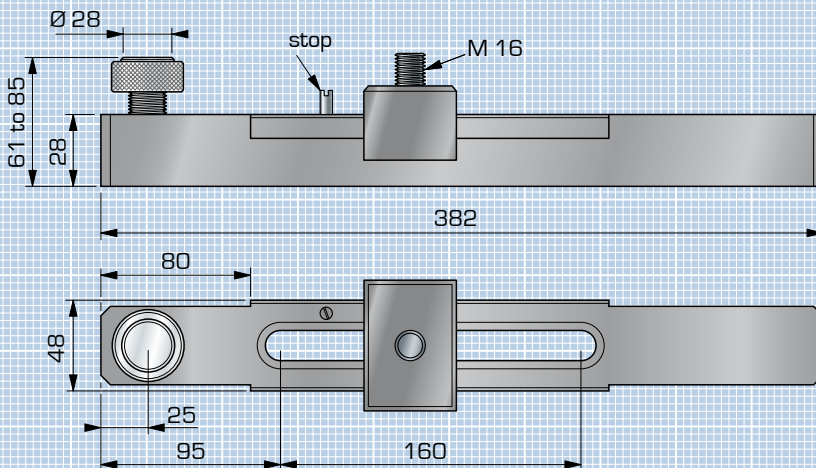
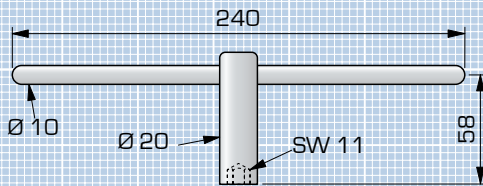

Spare parts

Piccolo

	Ref.
Worm screw 1 screw, 1 smooth ring	07-310
54 mm arm	07-315
100 mm arm	07-318
Clamping key	07-180
Swivel shoe	05-565



Monobloc - Bloc Bride

Worm screw 1 screw, 1 smooth ring	05-310
33 mm arm	05-315
61 mm arm	05-320
132 mm arm	05-322
Monobloc Clamping key	06-160
Bloc Bride Clamping key	05-180
Swivel shoe	05-565



Duo

Worm screw	21-310
Straight arm	21-330
Bent arm	21-335
Clamping key	06-160
Swivel shoe	05-565

KOPAL



Big Block

Worm screw 1 screw, 1 smooth ring	08-325
Positioning pin	08-150
50 mm arm	08-315
95 mm arm	08-320
145 mm arm	08-322
245 mm arm	08-323
Clamping key	08-160
Swivel shoe	08-330

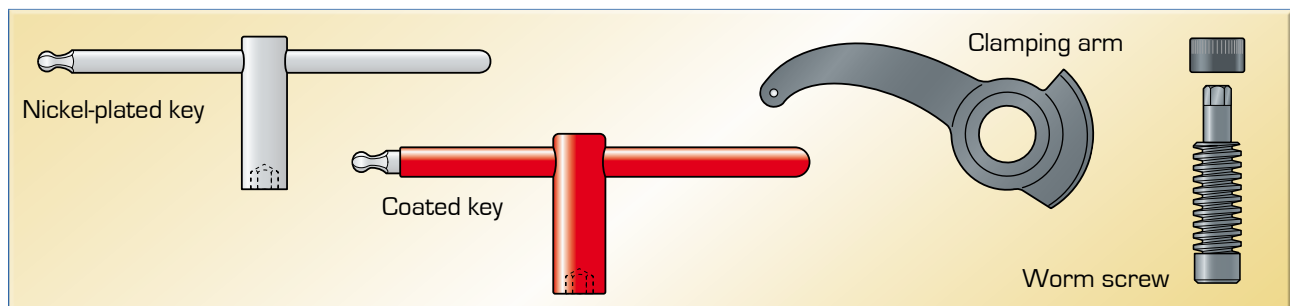
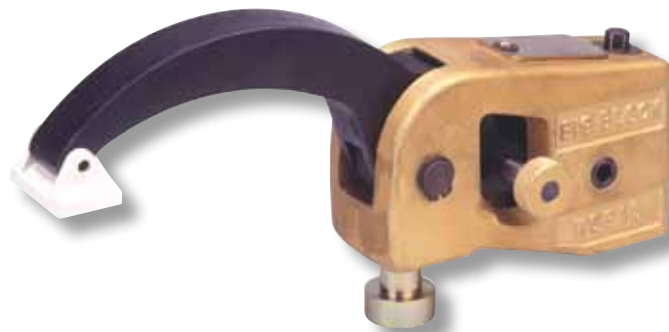

VERTICAL CLAMPING

Chain clamping 16000 N.

Chain clamping Equipment

with Standard chain

- Equipment with 0.99 M. chain
- Equipment with 1.981 M. chain
- Equipment with 2.971 M. chain

Ref.

06-040
06-044
06-043

16000 N.
8 m/kg

with Chain for protection clip

Protection clip supplied separately 

- Equipment with 0.99 M. chain
- Equipment with 1.981 M. chain
- Equipment with 2.971 M. chain

06-420
06-422
06-423

Includes :

- 1 Monobloc short arm 16000 N.
- 2 Chain (19.05)
- 3 Chain attachment block
- 4 Chain clip
- 5 Clamping key

Fixing screws supplied separately 

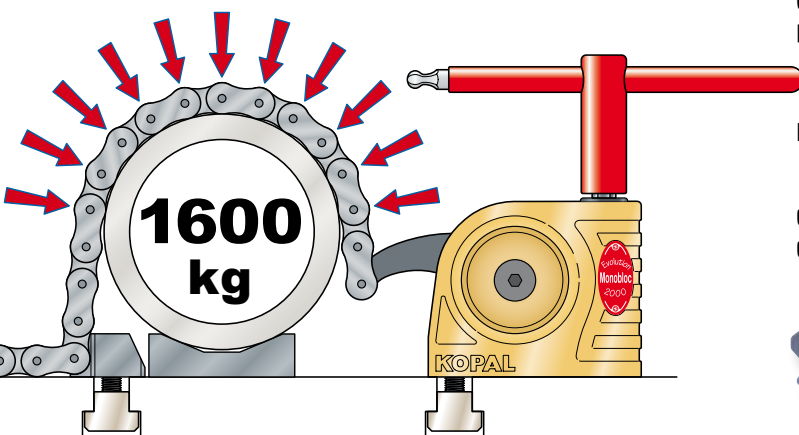
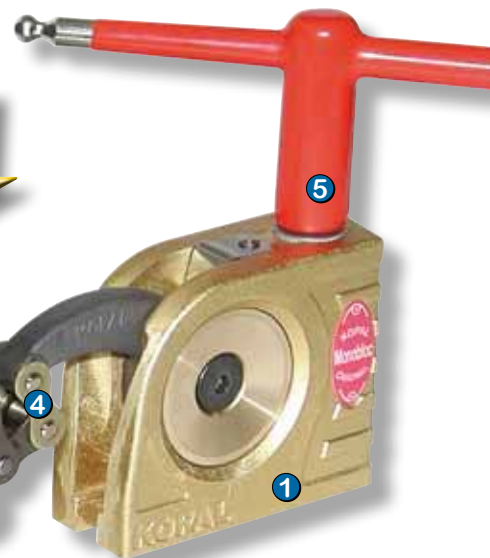

 distribution of clamping force

 Clamping of very large workpieces

The chain length, up to 3 meters, **longer on request**,  means you can clamp very large workpieces.

Components

Ref.

Standard Chain	0.971 M.	06-900
	1.962 M.	06-902
	2.952 M.	06-911
Chain for protection clip	0.971 M.	06-441
	1.962 M.	06-442
	2.952 M.	06-443
Protection clip	[1 piece]	06-430
	[set of 5 pieces]	06-435
	[set of 10 pieces]	06-437
Chain attachment block		06-910
Chain clip		06-905

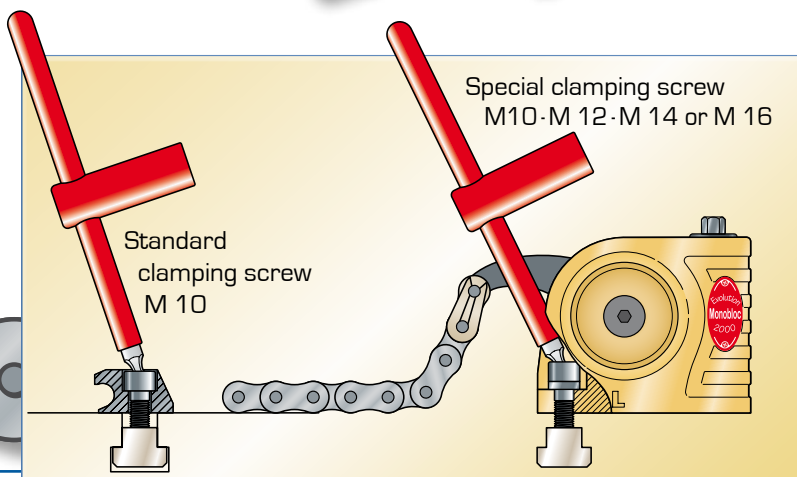

Chain clamping 16000 N.

Distribution of clamping force over a large area to prevent workpiece distortion.

Quick chain locking via a compact chain attachment block with M10 mounting.

Powerful and quick clamping with a Monobloc 16000 Newton clamp. Clamp or unclamp the workpiece at the turn of a key - the chain can then clear the workpiece completely.

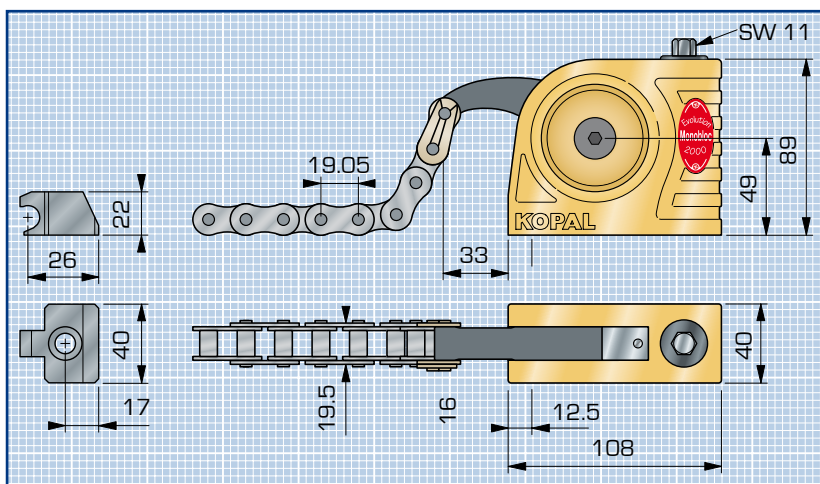
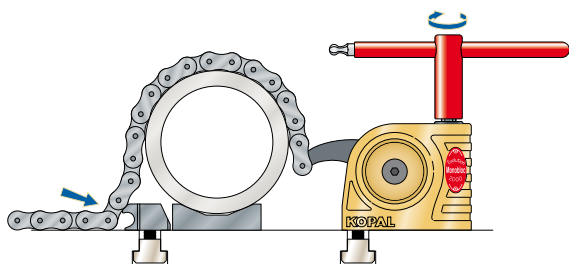

Fittings screw

for Clamp	Ref.
M10 x 35	06-080
M10 x 40	06-085
M10 x 45	06-090

for attachment block

M10 x 35	99-652
M10 x 40	99-653
M10 x 45	99-654



T-nuts M10 Ref.

14 mm	90-105
16 mm	90-110
18 mm	90-115
20 mm	90-120
22 mm	90-125
24 mm	90-130
28 mm	90-135

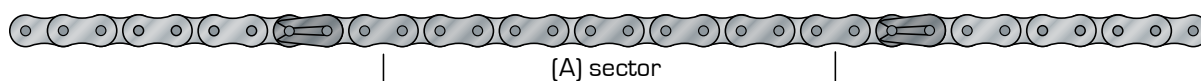

Information for use

The **protection clip** can be assembled on the **equipments** 06-420, 06-422, 06-423 on the **special chains** 06-441, 06-442, 06-443 in the center (A) sector of the chain.

0.99 M. of chain : 40 clips maxi.

1.981 M. of chain : 49 clips maxi.

2.971 M. of chain : 69 clips maxi.

Examples of using

Diameter of workpiece	Number of Clip	Maximum torque	Clamping force
100 mm	4 clips	1.6 m/kg	3200 N.
150 mm	6 clips	2.35 m/kg	4800 N.
200 mm	9 clips	3.26 m/kg	7200 N.
250 mm	10 clips	3.57 m/kg	8000 N.
300 mm	13 clips	4.5 m/kg	10400 N.

1 clip can support 800N.



KOPAL 57

VERTICAL CLAMPING

Workpiece Support

Used with Chain clamping 16000 and 50000 N.



Equipment

Ref.

Including :

06-470

- ① 1 x Mounting bar 400 mm
- ② 2 x Indexable 1/2 Ve support made of hardened steel with locator and screws

Locator and fixing screws for bar sold separately (depending on your t-slot).

Ve Support

Ref.

Including :

06-472

- ② 2 x Indexable 1/2 Ve support made of hardened steel.

Locators and fixing screws sold separately (depending on your t-slot).

KOPAL

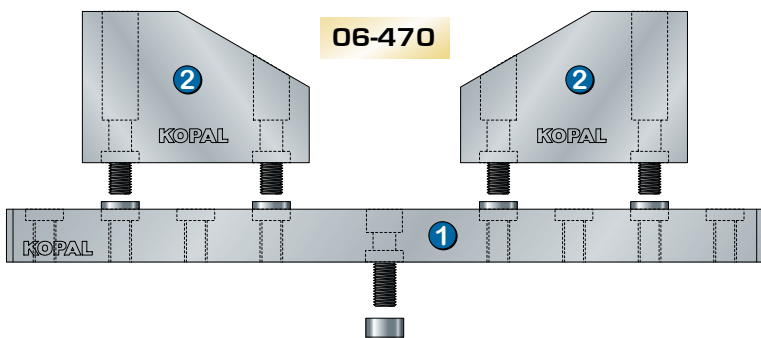

06-470

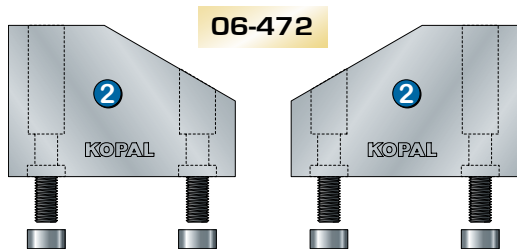

06-472



Mounting screw

M12 x 45	99-672
M12 x 50	99-674
M12 x 60	99-675
class 12/9	



T-slots	T-nuts M 12 Ref.	Locator Ref.
14 mm	90-105	09-885
16 mm	90-110	09-886
18 mm	90-115	09-888
20 mm	90-120	09-890
22 mm	90-125	09-892
24 mm	90-130	09-894
28 mm	90-135	09-898

The Mounting bar and 1/2 ve support are fixed on table t-slot with special Locators and M12 screws.

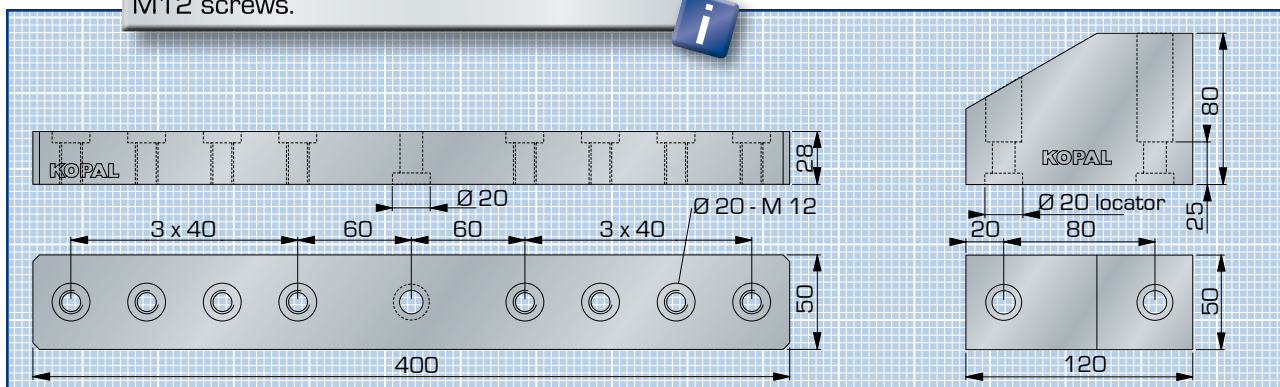

Terrific 11000 N.

Clamp with retractable arm

- Extremely compact clamp
- Ultra-quick action
- Arm retraction

Record clamping and unclamping times



Terrific Clamping Force	Clamping		Clamp with clamping key	Clamp without clamping key
	Reach	Height	Ref.	Ref.
11000 N.	30	22 to 26 mm	23-020	23-021

2 m/kg maximum clamping torque .

With clamping key and M10 x 35 mm clamping screw

Clamping key

23-150

11000 N.
2 m/kg

Use
For series assembly

Principle

When the key is turned two movements are carried out consecutively :

- A horizontal movement places the clamping arm in position for clamping.
- A vertical movement clamps the workpiece.

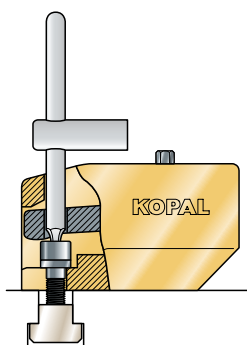
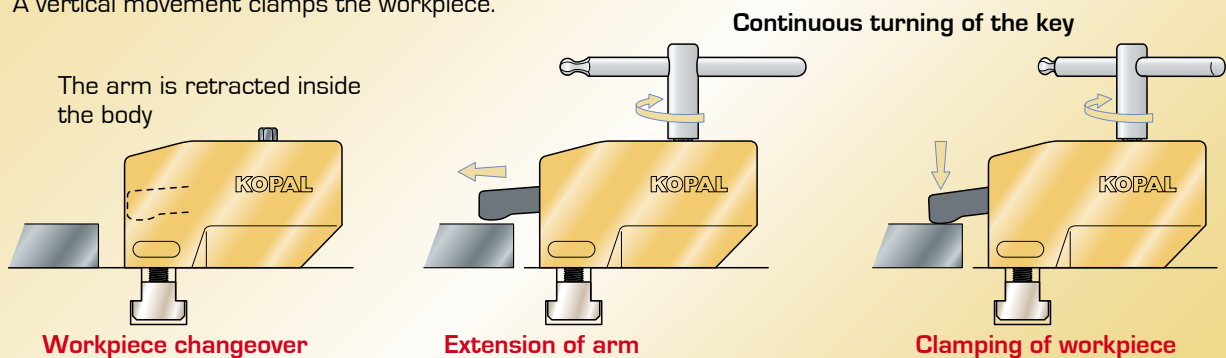

Simple and quick mounting with M 10 screw (provided)

KOPAL

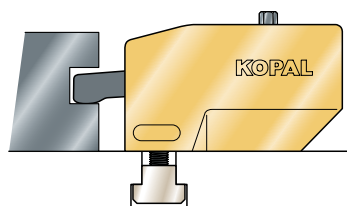

Compact, space-saving clamp

A mechanical clamp, which is particularly suitable for series production requiring extremely quick workpiece changeover.

VERTICAL CLAMPING

60 KOPAL

Terrific 11000 N.

Terrific fittings

Mounting screw

M 10 x 35

M 10 x 40

M 10 x 45

Mounting screw

M 12 x 40

M 14 x 45

M 16 x 45

Type

for slot sizes

12 and 14 mm

16 and 18 mm

20 and 22 mm

for tapped holes

M 12

M 14

M 16

Ref.

06-080

06-085

06-090

06-065

06-070

06-075



Set of 6 riser blocks

23-080

Aluminium riser blocks supplied with 6 x M10 screws of various lengths. These riser blocks can raise the clamping height of Terrific up to 126 mm

Riser block thicknesses : 2 - 4 - 8 - 16 - 32 - 64 mm.
M 10 x : 45 - 50 - 60 - 75 - 100 - 120 mm.

Match the length of the screw to the height of the riser block used.

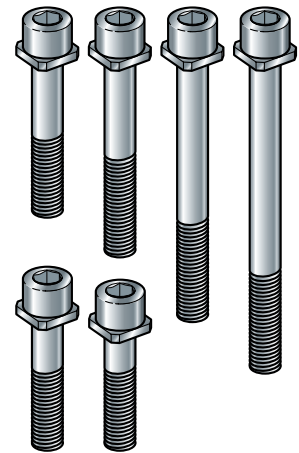
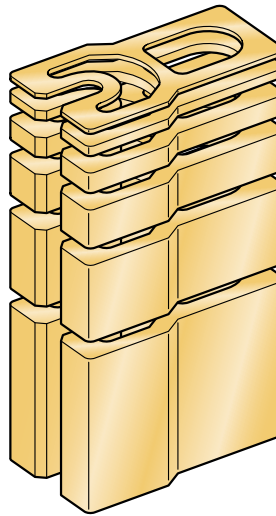

Mounting of riser blocks

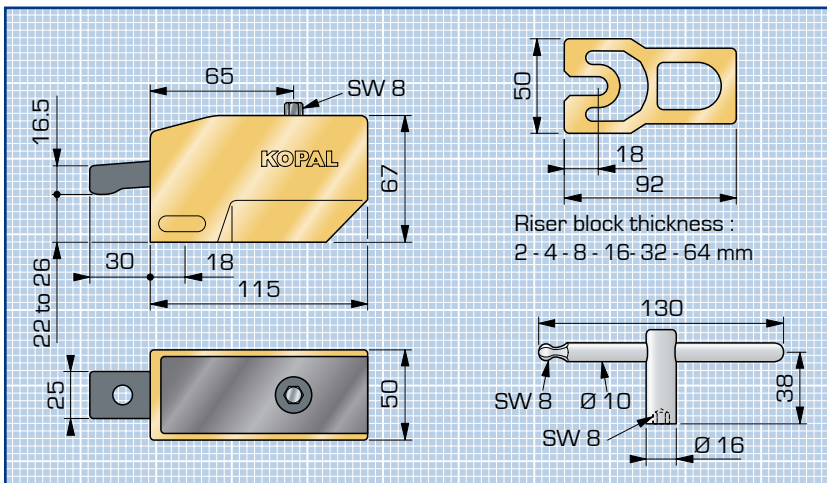
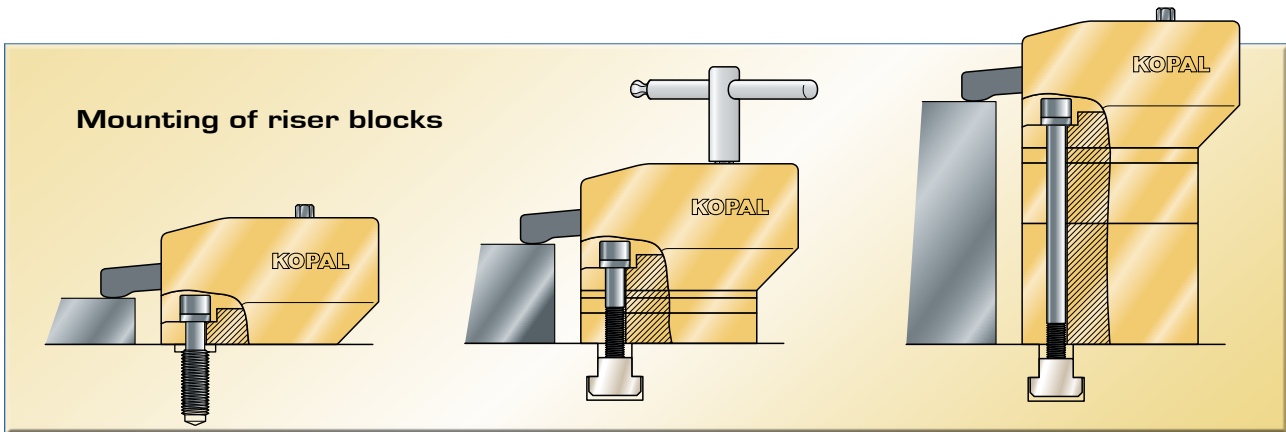

T-nuts M 10

Slot size	Ref.
12 mm	90-100
14 mm	90-105
16 mm	90-110
18 mm	90-115
20 mm	90-120
22 mm	90-125
24 mm	90-130
28 mm	90-135

KOPAL 61

VERTICAL CLAMPING

Maxibloc 35000 N.

- Steel clamp for heavy machining
- Extremely compact clamp
- Powerful clamping

Retractable arm



Maxibloc

All parts in steel

Clamping Force	Clamping Reach	Clamping Height	Clamp with clamping key Ref.	Clamp without clamping key Ref.
35000 N.	50	0 to 86	06-310	06-311

7 m/kg maximum clamping torque .

With clamping key, extension key and special clamping screw M14 

Nickel-plated clamping key, height 88 mm

06-325

Extension key

06-726

35000 N.
7 m/kg

- For T-slot tables with slot size from 16 mm and M 14 and M 16 modular tables.
- Mounting with 1 screw.
Compact clamp with direct workpiece clamping.
Very simple course adjustment and retraction of clamping arm.

KOPAL

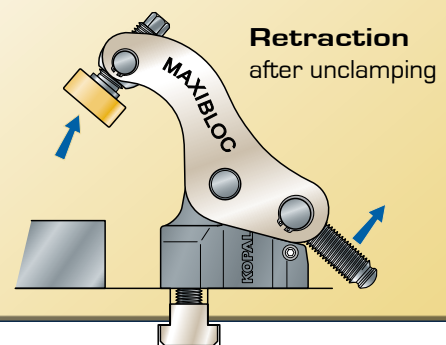
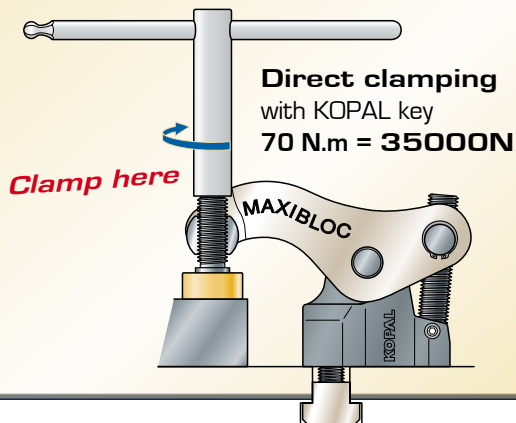
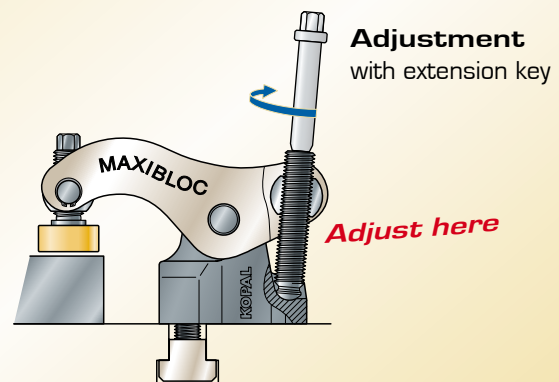
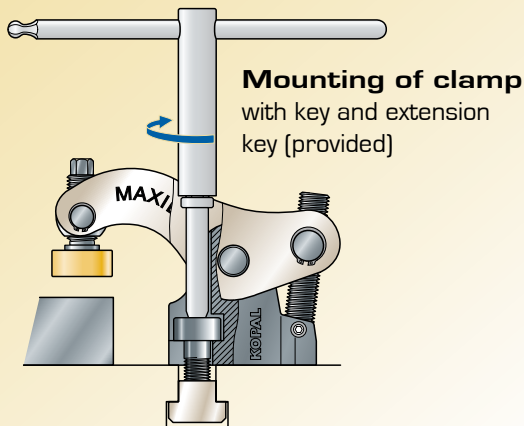

Maxibloc 35000 N.

Mounting screws

Ref.

Special large-head, SW 8 mm

M 14 x 40 mm

06-720

M 16 x 44 mm

06-721

M 16 x 60 mm

06-723

Riser block

Steel stackable riser block, supplied with a M 14 mounting screw

80 mm riser block

06-320



T-nuts Slot size	M 14 Ref.	M 16 Ref.
16 mm	90-202 *	
18 mm	90-205	90-250
20 mm	90-210	90-255
22 mm	90-215	90-260
24 mm	90-220	90-265
28 mm	90-225	90-270

* long T-nut

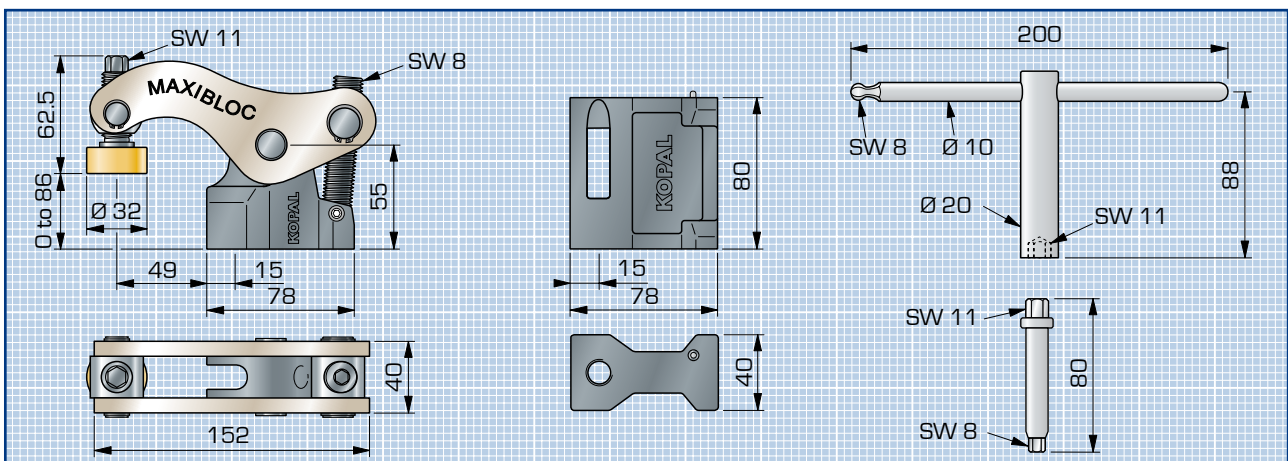
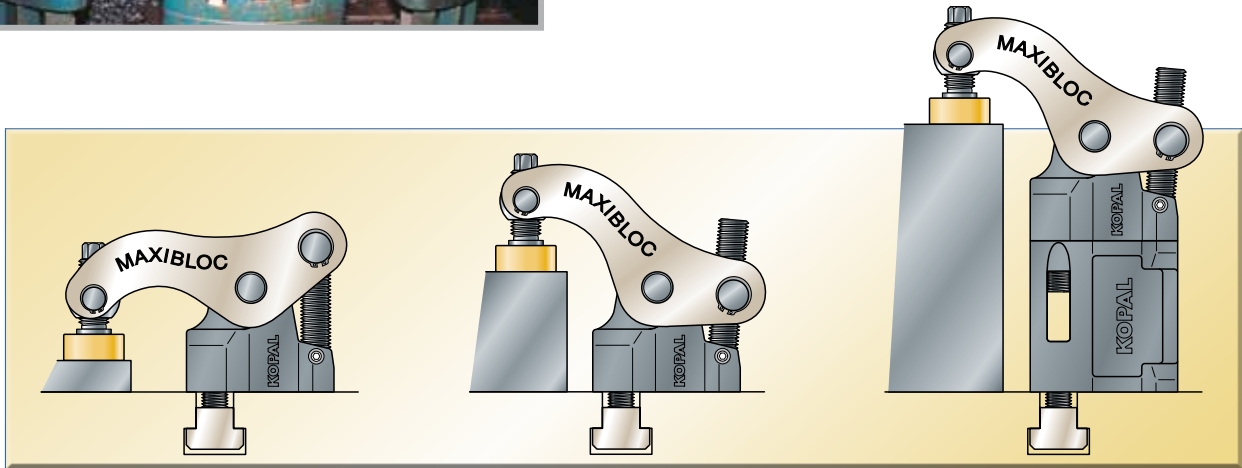

Blocapress 50000 N.

- Extremely high mechanical strength
- Entirely made from hardened steel
- For very powerful presses



Blocapress			Clamp with clamping key Ref.	Clamp without clamping key Ref.
Clamping Force	Clamping Reach	Clamping Height		
50000 N.	30	14 to 92	08-341	08-340

9 m/kg maximum clamping torque.

Clamping keys and screws sold separately

KOPAL

**50000 N.
9 m/kg**

Mounting on T-slot table using a high strength M16 screw

Course adjustment with $\varnothing 24$ adjusting wheel or 5mm hexagonal key

for Press tools

Clamping with 13mm socket key

The unique mounting point makes it possible to swivel

Ref. **08-342**

Set of 3 clamping keys
Including :
1 sliding handle (1/2" square)
1 hexagonal socket 13 mm
2 male hexagonal keys : 5 and 14mm

M 16 mounting screw
Class 12.9 (ISO-Standard)

M 16 x 60 mm screw **99-682**
M 16 x 60 mm screw **99-684**

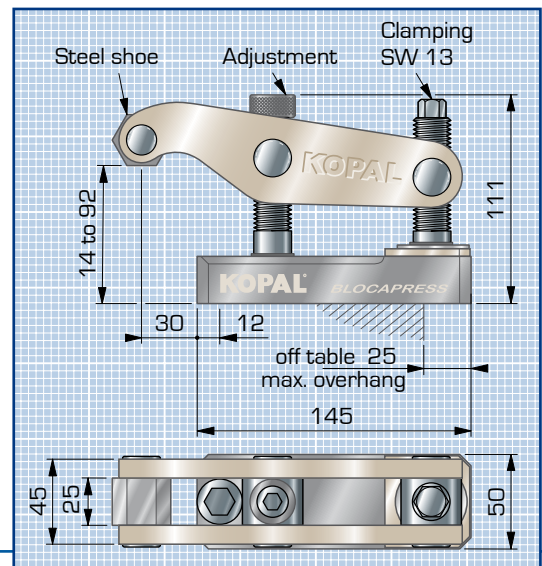

Screw for Monobloc - Duo

		Ref.
M 10 x 35	12 and 14 mm	06-080
M 10 x 40	16 and 18 mm	06-085
M 10 x 45	20 and 22 mm	06-090
M 12 x 40	M 12	06-065
M 14 x 45	M 14	06-070
M 16 x 45	M 16	06-075



Important
Always use special
KOPAL screws

Fixture for Bloc Bride

Special T-nuts, screws and spring	Ref.
slot 12 mm	05-200
slot 14 mm	05-205
slot 16 mm	05-210
slot 18 mm	05-215
slot 20 mm	05-220
slot 22 mm	05-225



Screw for Piccolo

	Ref.
M 8 x 30 mm	07-720
M 10 x 35 mm	07-730
M 12 x 35 mm	07-735



Fixture for Big Block

Special studs with cylinder	Ref.
mounting of Big Block on table	
V2-C1 M 14 x 62 mm	08-060
V2-C1 M 14 x 82 mm	08-070
V2-C2 M 16 x 70 mm	08-080
V2-C2 M 16 x 80 mm	08-090



Screw for Maxibloc

	Ref.
M 14 x 40 mm	06-720
M 16 x 44 mm	06-721
M 16 x 60 mm	06-723



Special studs	Ref.
mounting of base on table	
V2-1 M 14 x 60 mm	08-100
V2-1 M 14 x 80 mm	08-110
V2-2 M 16 x 65 mm	08-120
V2-2 M 16 x 85 mm	08-130



Adapter	Ref.
Mounts the Big Block onto riser blocks and the base	08-140



T-slot covers
page 70



VERTICAL CLAMPING



T-nuts for
T-slots

Slot size	M 8 Ref.	M 10 Ref.	M 12 Ref.	M 14 Ref.	M 16 Ref.
10 mm	90-050				
12 mm	90-055	90-100			
14 mm	90-060	90-105	90-150		
16 mm	90-065	90-110	90-155	90-200	
18 mm	90-070	90-115	90-160	90-205	90-250
20 mm		90-120	90-165	90-210	90-255
22 mm		90-125	90-170	90-215	90-260
24 mm		90-130	90-175	90-220	90-265
28 mm		90-135	90-180	90-225	90-270

VERTICAL CLAMPING

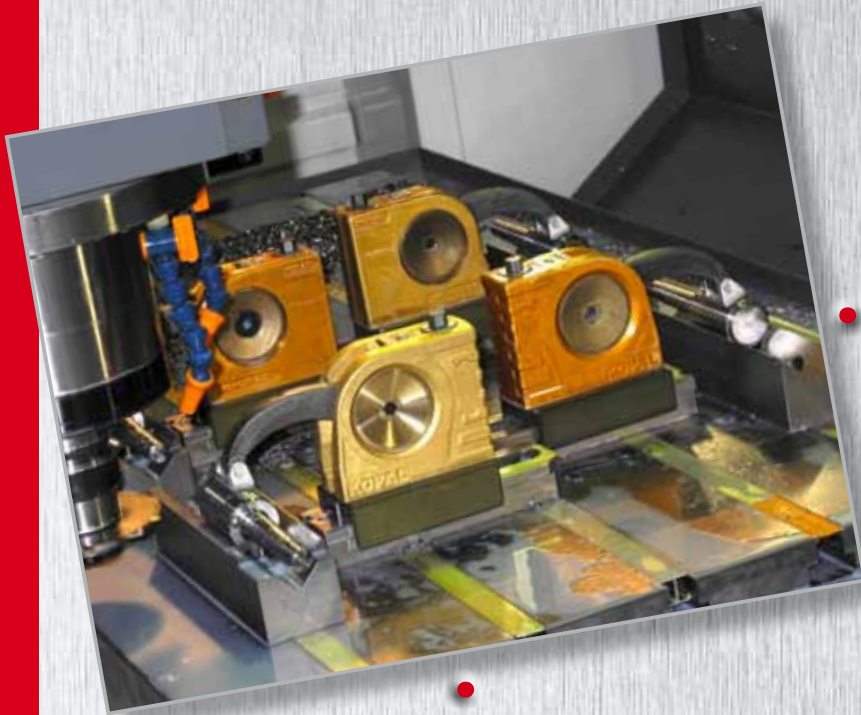

KOPAL





Power regulators for vices

KOPAL®



Power regulators FORCE	68 - 69
Interchangeable tips	69
Fixed jaws with V-guides	70

KOPAL 67

REGULATORS FOR VICES

Force

Allows simultaneous clamping of several workpieces of different sizes or shapes in the same vice.

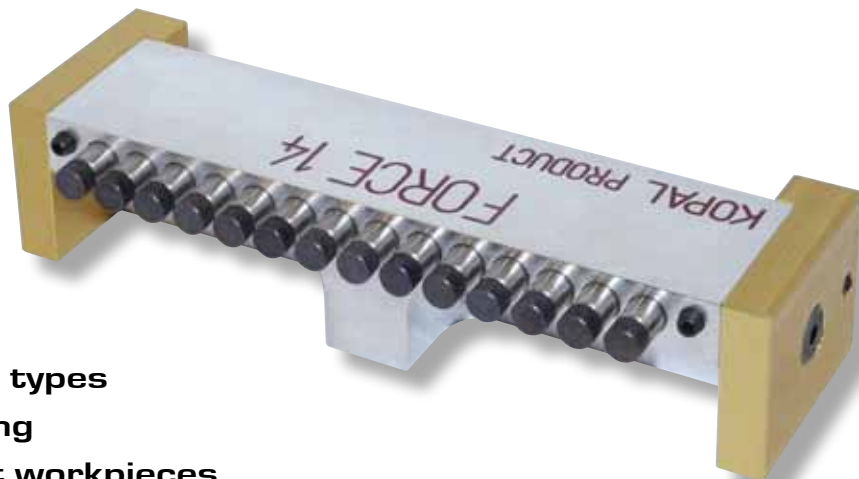

- Adapts to all vice types
- Multiple clamping
- Curved or cast workpieces
- Cylindrical workpieces

KOPAL

Regulator Force	Vice width	Number of pistons	A	B	C	D	E	F	G	H	Ref.
F 12 with tips	100 to 135	12 Ø 8	41 - 49	3 - 11	10	110	7	39	49	156	27-313
F 12			46 - 54	8 - 16							27-312
F 14 with tips	125 to 160	14 Ø 8	41 - 49	3 - 11	10	130	7	39	49	181	27-315
F 14			46 - 54	8 - 16							27-314
F 18 with tips	175 to 200	12 Ø 12	52 - 62	3 - 13	16	176	10	49.5	61.5	230	27-319
F 18			57 - 67	8 - 18							27-318

FORCE can be adapted in seconds to any type of vice (from 100 to 200 mm) and is the ideal accessory for all types of mechanical, pneumatic or hydraulic vices.



The long stroke and multiple points of contact of the pistons ensure powerful and effective clamping.

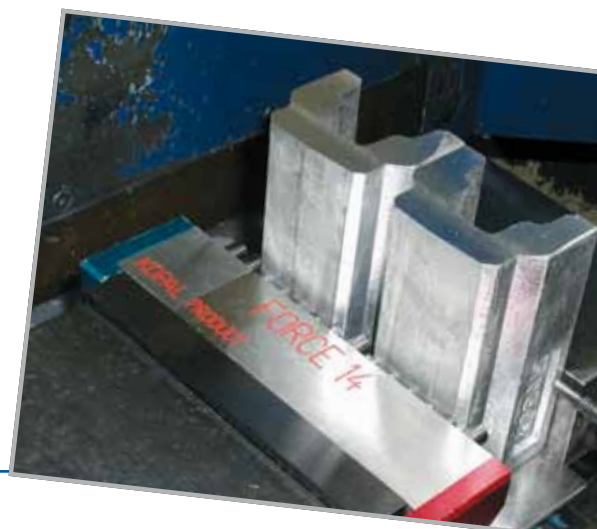
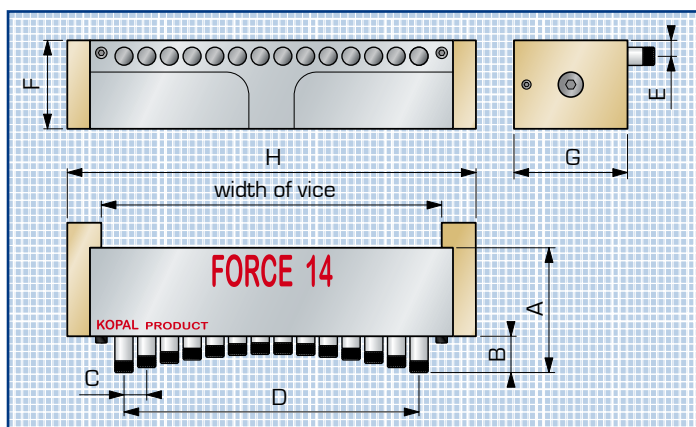
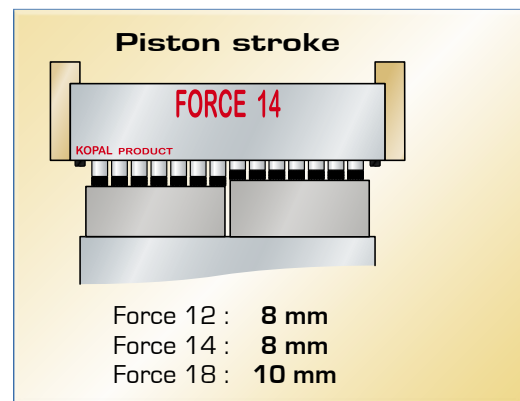

Principle

The clamping pistons are linked together via a closed hydraulic circuit.

The degree to which each piston is retracted doesn't matter - the clamping force exerted by each of the pistons is identical.



Maximum recommended vice force in Newton (vice power)

	Force 12			Force 14			Force 18			
	Nb. of pistons used	12	10	8	14	12	10	12	10	8
Maximum force	42000	35000	28000	49000	42000	35000	92000	77000	61000	

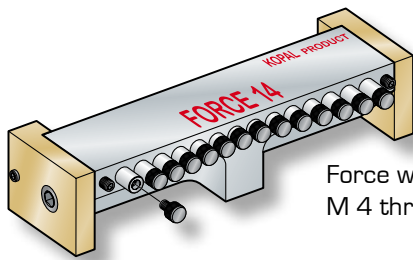

Force with M 4 threaded pistons

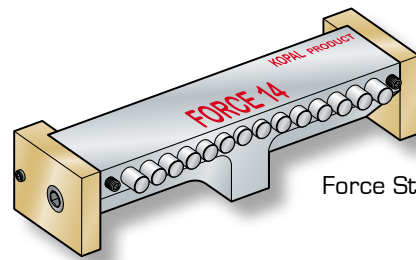

Force Standard

Interchangeable tips

The tapped pistons allow you to fit the appropriate tips for different shaped workpieces.

Flat tips for finished workpieces

Grooved tips for raw workpieces

Ball-ended tips for curved workpieces

Pointed tips

for Force with tapped pistons

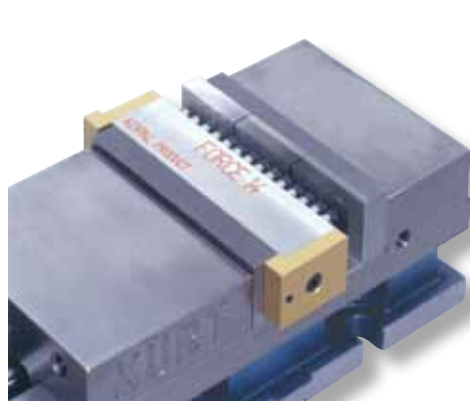
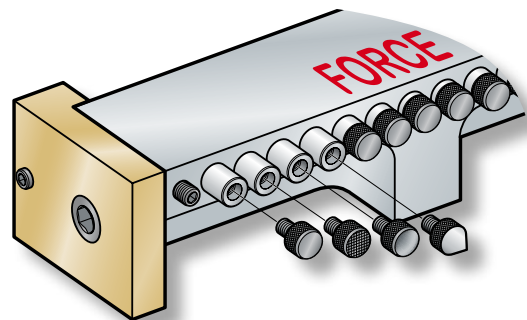

Set of tips for :

	Force 12 Ø 8 x 12 tips Ref.	Force 14 Ø 8 x 14 tips Ref.	Force 18 Ø 12 x 12 tips Ref.
Flat tips	27-411	27-421	27-431
Grooved tips	27-414	27-424	27-434
Ball-ended tips	27-412	27-422	27-432
Pointed tips	27-413	27-423	27-433

Force

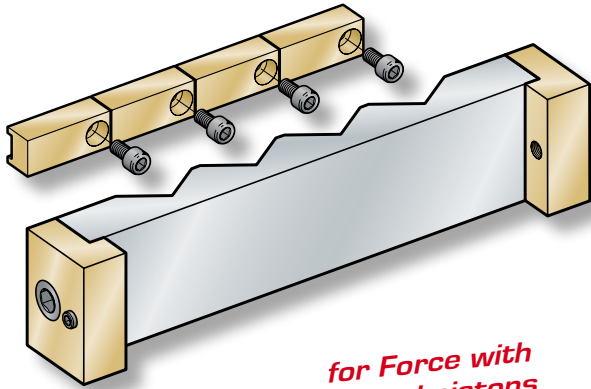

*for Force with
tapped pistons*

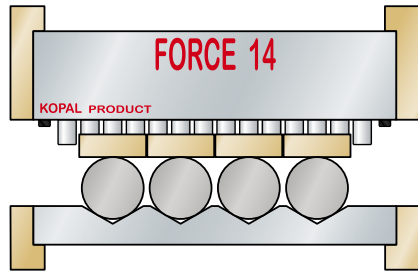

Fixed jaws with V-guides

For vertical clamping of cylindrical workpieces. Fixed jaws with mounting flanges and blocks linking the pistons.



Fixed jaws	Vice width	Number of V	Number					Ref.
			A	B	C	D	E	
for Force 12	100 to 135	12	10					27-351
		6	20	17	30	40	156	27-352
		4	30					27-353
for Force 14	125 to 160	14	10					27-361
		7	20	17	30	40	181	27-362
		4	30					27-363
for Force 18	175 to 200	12	16					27-371
		6	32	20	30	50	230	27-372
		4	48					27-373

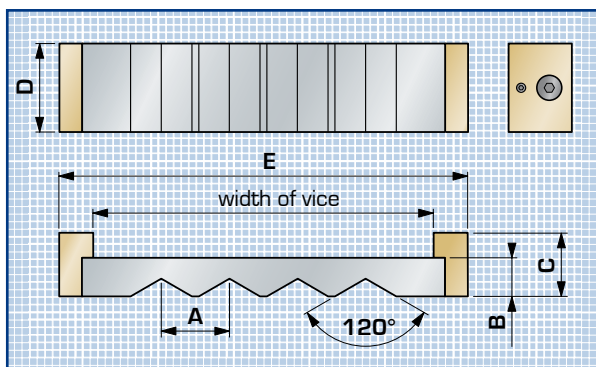

REGULATORS FOR VICES



Chamfering devices system KOPAL®



KOPAL®



Presentation	80
Inner devices	81
Inner devices Slim Line	82
Outer devices	83
Devices for Tubes (Inner and Outer)	84
Spare parts	85
Cutting blades	86 - 87

Principle

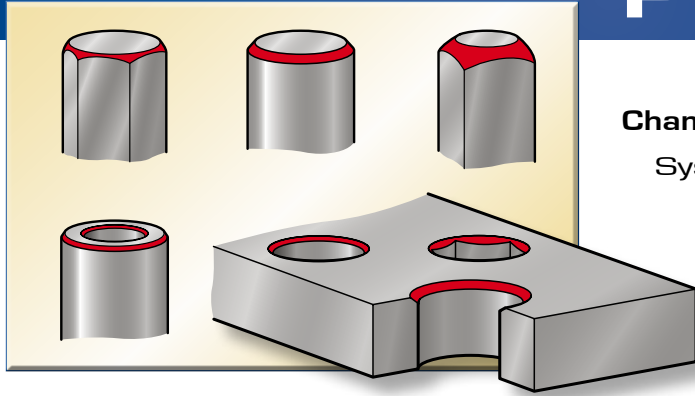

Chamfering devices mainly for drills

Système KOPAL®

- Concentric chamfer
- Excellent surface quality
- No risk of cutting into the workpiece
- Controlled machining torque

This device works as a carpenter's plane.

The output adjusting of the blade controls the thickness of the chip and not the value of the chamfer.

Ex. : blade output of 0.1 mm
the device will make 10 turns
for cut 1 mm.

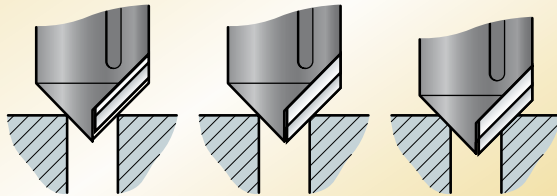

When the spindle is lowered, the pilot cone centres the workpiece, retracts and allows the blade to come out.

KOPAL®



i Lubricate with cutting fluid or oil to ensure long life for the blade's cutting edge and slow down erosion of the pilot cone.



● **Devices with standard treatment of pilot and HSS blade**

Suitable to most usual materials and small series.



● **Devices with standard treatment of pilot and TIN coating HSS blade**

Suitable to materials difficult to machine. Stainless steel, Inconel, Titanium and small series.



● **Devices with CRN treatment of pilot and TIN coating HSS blade**

Suitable to materials difficult to machine. Stainless steel, Inconel, Titanium and important series.

HÄBERLE®
Deburring Machine

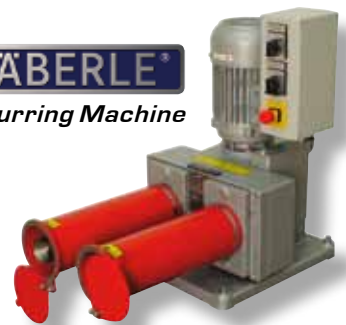

Recommended cutting speed
between 10 and 20 m/min.

example : Ø 10 mm	320 to 640 rpm
Ø 15 mm	210 to 420 rpm
Ø 20 mm	160 to 320 rpm
Ø 30 mm	110 to 220 rpm
Ø 40 mm	80 to 160 rpm
Ø 60 mm	55 to 110 rpm

$$Rpm = \frac{\text{cutting speed} \times 1000}{\text{Diameter} \times 3.14}$$

Inner Devices

Chamfers any cylindrical, polygonal, or interrupted hole edges at 90°.

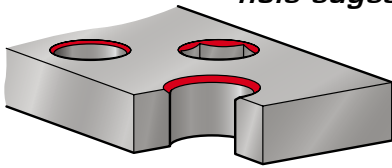

Chamfering angle
60°, 82°, 90° and 120°

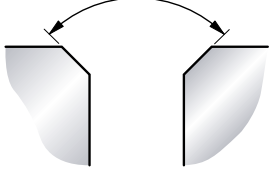

Inner Devices

Without cutting blade

Hole diameter to chamfer	Model	Attach.	A	B	C 60°/90°	Type of cone pilot						
						Standard		CRN		Standard		
						60° Ref.	90° Ref.	60° Ref.	90° Ref.	82° Ref.	120° Ref.	
4 to 17	2-18	Ø 10 MK 1	Ø 18	Ø 26	64/55	01-030	01-010	1W030B	1W010B	01-050	01-080	
						01-035	01-015	1W035B	1W015B			
5 to 41	2-42	Ø 10/16 Ø 12.7 MK 1 MK 2 MK 3 weld on Ø19	Ø 42	Ø 65	108/85	01-120	01-095	1W120B	1W095B	01-150	01-141	01-191
						01-125	01-100	1W125B	1W100B			
						01-115	01-090	1W115B	1W090B			
						01-116	01-091	1W116B	1W091B			
						01-117	01-092	1W117B	1W092B			
							01-093					
21 to 59	20-60	MK 2	Ø 60	Ø 70	106/94	01-215	01-210					
42 to 77	40-80	MK 2 MK 3	Ø 80	Ø 90	114/100	01-230	01-225					
						01-231	01-226					
62 to 97	60-100	MK 3	Ø 100	Ø 110	104		01-241					
82 to 117	80-120	MK 3	Ø 120	Ø 130	104		01-256					

KOPAL

HSS blades
0°, 14°, 20° and 25° cutting angle

TIN coating HSS blades
20° cutting angle

Carbide blade
0° cutting angle



Models and information

Page 86

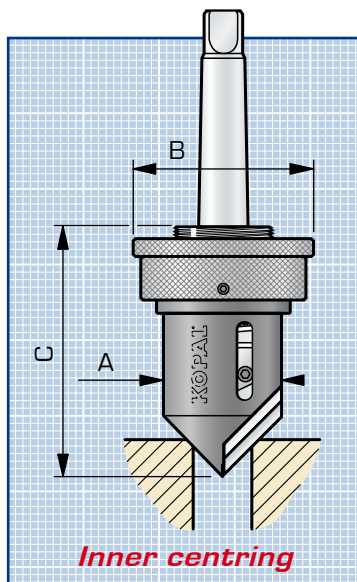
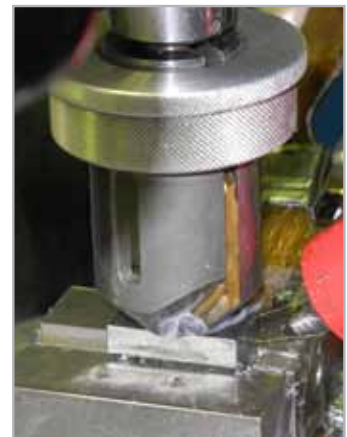

Inner compact devices available

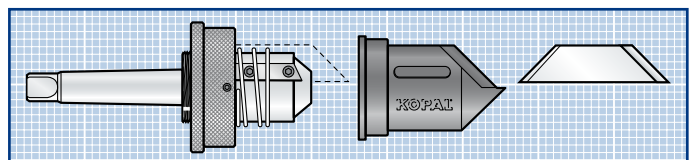

KOPAL 81

CHAMFERING

Inner compact Devices

Chamfers any cylindrical, polygonal, or interrupted hole edges at 90°.

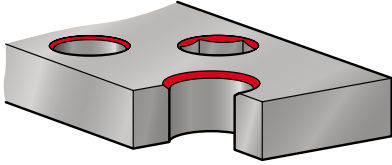

SLIM LINE
compact devices



KOPAL

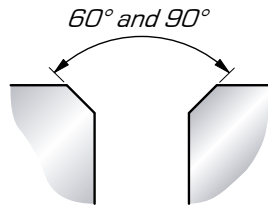

Inner Devices - SLIM LINE

Without cutting blade

Standard

Hole diameter to chamfer	Model	Attach.	A	B 60°/90°	60°	90°
					Ref.	Ref.
4 to 17	2 - 18	Ø 10 6 WS 6.35	Ø 19.5	78/68	03-015	03-010 03-011
11 to 30	10 - 30	MK 1	Ø 32	112/100	03-035	03-020
		MK 2			03-036	03-021
		Ø 12			03-040	03-025
5 to 40	4 - 42	MK 2 Weldon Ø 20 Ø 12.7	Ø 44	135		03-051 03-053 03-055

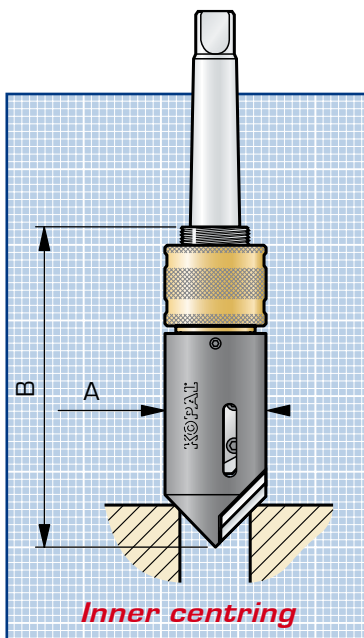

HSS blades
0°, 14°, 20° and
25° cutting angle

Carbide blade
0° cutting angle

Models and information

Page 87

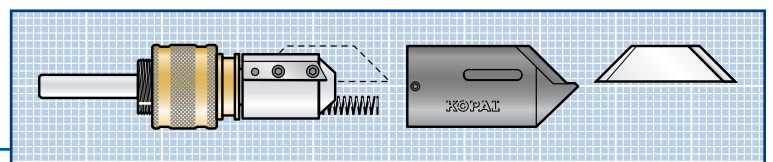
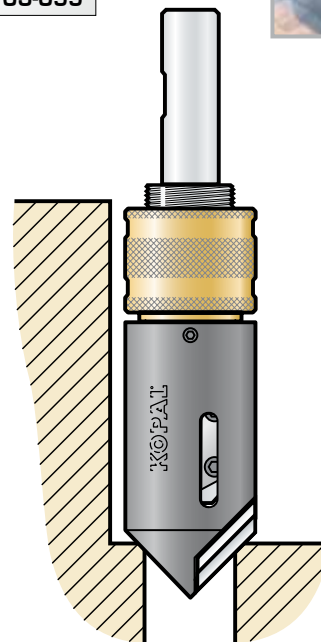

Outer Devices

Chamfers all tube ends
and cylindrical

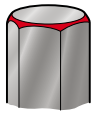

or polygonal bar ends

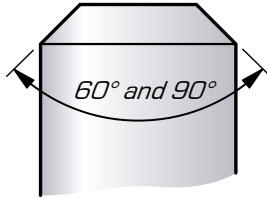
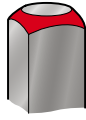

KOPAL

Outer Devices Without cutting blade

Type of cone pilot
Standard CRN

Diameter to chamfer	Model	Attach.	A	B	C 60°/90°	Standard		CRN	
						60° Ref.	90° Ref.	60° Ref.	90° Ref.
4 to 17	2 - 18	Ø 10 MK 1	Ø 18	Ø 26	54	02-020	02-010	2W020B	2W010B
4 to 37	2 - 36	Ø 10/16 MK 2	Ø 42	Ø 65	105/85	02-055	02-035	2W055B	2W035B
10 to 45	10 - 46	Ø 10/16 MK 2	Ø 48	Ø 65	109/85	02-110	02-095	2W050B	2W030B
21 to 57	20 - 60	MK 2	Ø 60	Ø 70	108/85	02-105	02-090		
41 to 77	40 - 80	MK 2 MK 3	Ø 80	Ø 90	118/95	02-140	02-135		
60 to 97	60 - 100	MK 3	Ø 100	Ø 110	107	02-155	02-150		
80 to 117	80 - 120	MK 3	Ø 120	Ø 130	110	02-156	02-151		
							02-166		
							02-181		

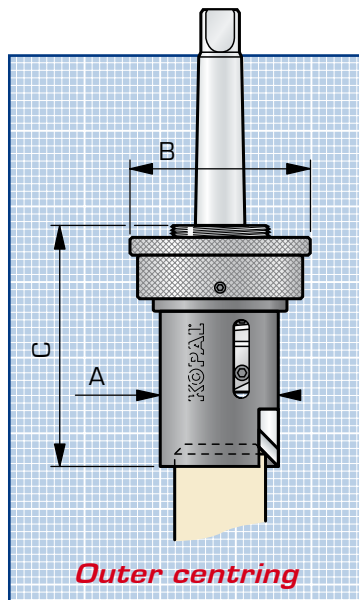

Outer centring

HSS blades
0°, 14°, 20° and 25° cutting angle

TIN coating HSS blades
20° cutting angle

Carbide blade
0° cutting angle



Models and information

Page 86

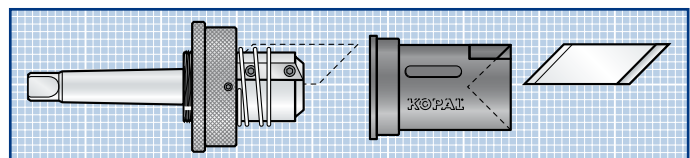

KOPAL 83

CHAMFERING

Inner / Outer Devices

Simultaneously chamfers
the **Inside and Outside**
of tube ends

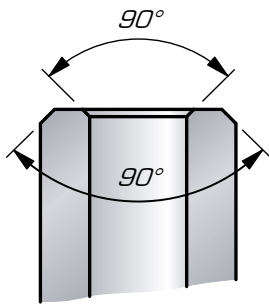

KOPAL TUBE



KOPAL TUBE Devices

Without cutting blade

Standard pilot

Tube diameter Inner	Outer	Model	Attach.	A	B	90° Ref.
12 to 24	14 to 24	K 1	Ø 12.7 MK 2	Ø 46	90	04-060 04-050
15 à 27	18 to 30	K 2	Ø 12.7 MK 2	Ø 58	105	04-080 04-070
20 to 30	24 to 36	K 3	Ø 12.7 MK 2	Ø 61	110	04-100 04-090
29 to 40	34 to 45	K 4	Ø 12.7 MK 2	Ø 67	112	04-120 04-110
40 to 48	46 to 56	K 5	Ø 12.7 MK 2	Ø 82	120	04-140 04-130

Use

These units are supplied with
2 removable pilot cones

Larger inner
chamfer than
outer chamfer.

Use the inner cone
to centre the
workpiece.

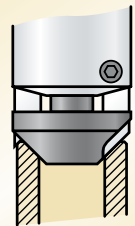

Larger outer
chamfer than
inner chamfer.

Use the outer cone
to centre the
workpiece.

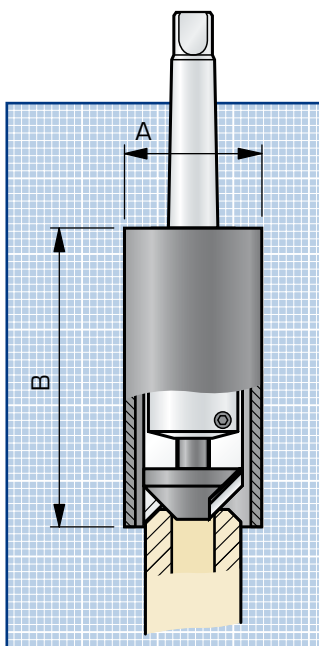
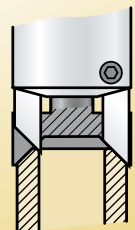

HSS Blades

14° and 20° cutting angles

Models and information

Page 87



Blades can be adjusted independently
so **the chamfers can therefore have
different values.**

KOPAL

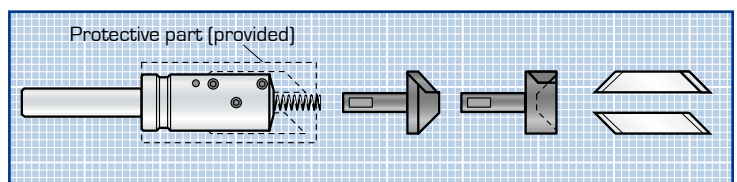

Spare Parts

Pilot

for **Inner**
device model

	Ref.
2-18 90°	01-510
2-18 60°	01-520
2-18 82°	01-530
2-42 90°	01-550
2-42 60°	01-555
2-42 82°	01-560
2-42 120°	01-570
20-60 90°	01-575
20-60 60°	01-580
40-80 90°	01-590
40-80 60°	01-595
60-100 90°	01-605
80-120 90°	01-620

for **Inner**
device **Slim Line** model

3-19 90°	03-510
3-19 60°	03-515
10-30 90°	03-520
10-30 60°	03-525
4-42 90°	03-530

for **Outer**
device model

2-18 90°	02-510
2-18 60°	02-515
2-36 90°	02-520
2-36 60°	02-525
10-46 90°	02-535
10-46 60°	02-540
20-60 90°	02-550
20-60 60°	02-555
40-80 90°	02-565
40-80 60°	02-570
60-100 90°	02-580
80-120 90°	02-595

Nut

for **Inner** and **Outer**
device model

	Ref.
2-18	01-750
2-42	01-760
20-60	01-770
40-80	01-775
60-100	01-780
80-120	01-785

for **Inner Slim Line** model

3-19	03-610
10-30	03-615
4-42	03-620

Lock nut

for **Inner** and **Outer**
device model

2-18	01-755
2-42	01-765
20-60	

for **Inner Slim Line** model

3-19	03-611
------	--------

Spring

for **Inner** and **Outer**
device model

2-18	01-820
2-42	01-825
20-60	01-830
40-80	01-835
60-100	01-837

for **Inner Slim Line** model

4-42	03-645
10-30	03-640

Body

for **Inner**
device model

	Ref.
2-18 90° Attach. Cyl. 10	01-630
2-18 90° Attach. MK 1	01-635
2-18 60° Attach. Cyl. 10	01-640
2-18 60° Attach. MK 1	01-645
2-42 90° Attach. MK 1	01-650
2-42 90° Attach. MK 2	01-651
2-42 90° Attach. MK 3	01-652
2-42 90° Attach. Ø 10-16	01-655
2-42 90° Attach. Ø 1/2"	01-660
2-42 60° Attach. MK 2	01-676
2-42 60° Attach. MK 3	01-677
2-42 60° Attach. Ø 1/2"	01-685
20-60 90° Attach. MK 2	01-690
20-60 60° Attach. MK 2	01-695

for **Inner**
device **Slim Line** model

3-19 90°	03-555
3-19 60° Attach. Ø 10	
10-30 90°	03-561
10-30 60° Attach. MK 2	
4-42 90° Attach. MK 2	03-576

for **Outer**
device model

2-36 90° Attach. MK 2	02-610
2-36 90° Attach. Ø 10-16	02-615
10-46 90° Attach. MK 2	02-630
10-46 90° Attach. Ø .10-16	02-635
10-46 90° Attach. Ø 1/2"	02-640
20-60 90° Attach. MK 2	02-645

 **Blades**
pages 86 and 87

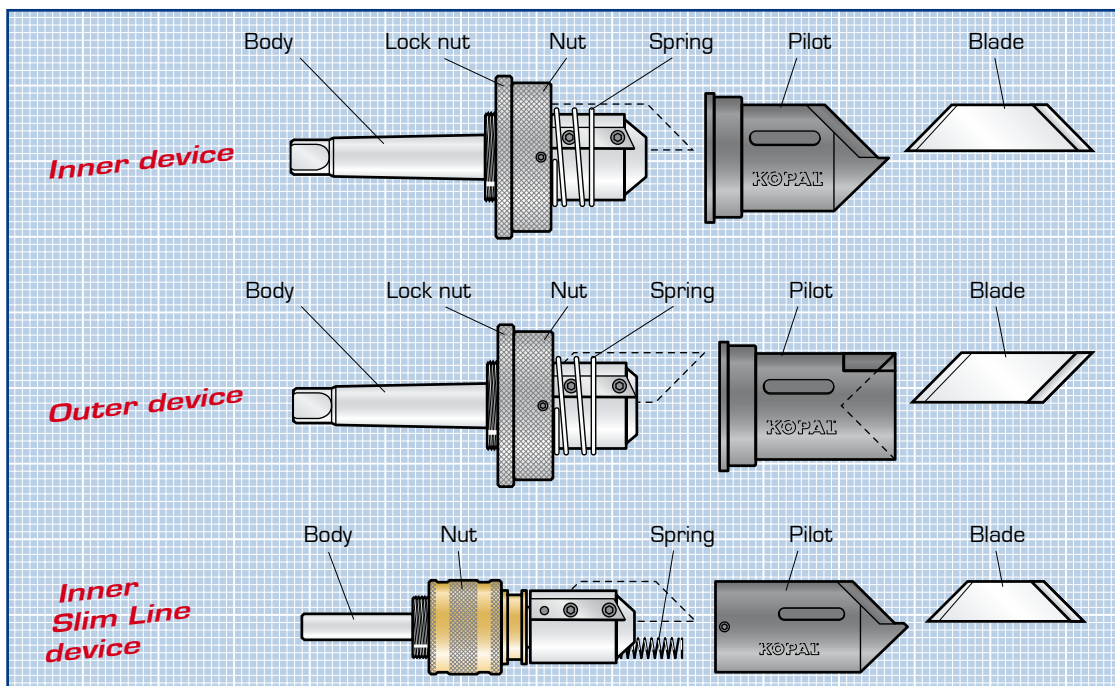

Cutting blades

Blade for inner chamfering device

0° cutting angle for device model :	Ch.60°	Ch.90°	Ch.82°	Ch.120°	Ch.60°	Ch.90°
	HSS				Carbide	
2 - 18	01-303	01-323		01-334		
2 - 42	01-343	01-353	01-336	01-364		
20 - 60 to 80 - 120	01-363	01-373			01-341	01-351

14° cutting angle for device model :	Ch.60°	Ch.90°	Ch.82°	Ch.120°
	HSS			
2 - 18	01-305	01-320		01-335
2 - 42	01-340	01-350	01-345	01-360
20 - 60 to 80 - 120	01-365	01-370		

20° cutting angle for device model :	Ch.60°	Ch.90°	Ch.82°	Ch.120°	Ch.60°	Ch.90°
	HSS				TIN	
2 - 18	01-308	01-328		01-338	1T305B	1T320B
2 - 42	01-348	01-358	01-342	01-368	1T340B	1T350B
20 - 60 to 80 - 120	01-361	01-378				

25° cutting angle for device model :	Ch.60°	Ch.90°	Ch.82°	Ch.120°
	HSS			
2 - 18	01-309	01-329		01-339
2 - 42	01-349	01-359	01-344	01-369
20 - 60 to 80 - 120	01-362	01-379		



Devices
page 81

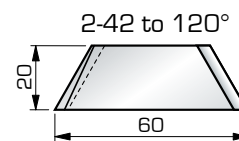
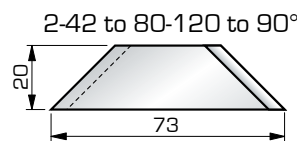
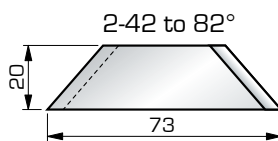
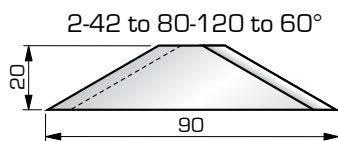
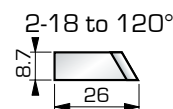
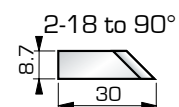
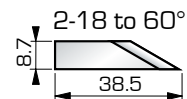

- **HSS blade - 0° to 25°**
for most usual materials
- **TIN coating HSS blade - 20°**
for materials difficult to machine :
Stainless steel, Inconel, Titanium
- **Carbide blade - 0°**
for hard materials

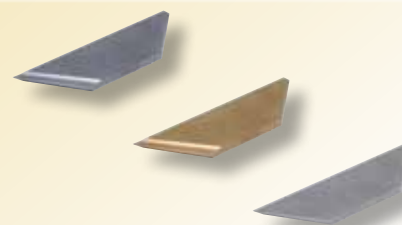

Devices
page 83

Blade for outer chamfering device

0° cutting angle for device model :	60°	90°
	HSS	
2 - 18	02-303	02-304
2 - 36 to 80 - 120	02-317	02-312

14° cutting angle for device model :	60°	90°
	HSS	
2 - 18	02-305	02-300
2 - 36 to 80 - 120	02-315	02-310

20° cutting angle for device model :	60°	90°	60°	90°
	HSS		TIN	
2 - 18	02-308	02-302	2T305B	2T300B
2 - 36 to 80 - 120	02-318	02-313	2T315B	2T310B

25° cutting angle for device model :	60°	90°
	HSS	
2 - 18	02-307	02-306
2 - 36 to 80 - 120	02-319	02-314

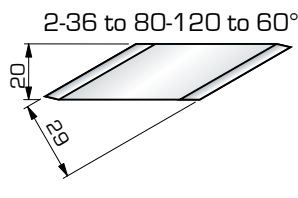
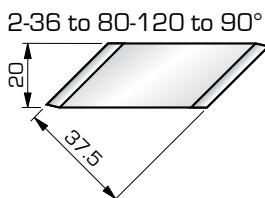
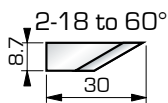
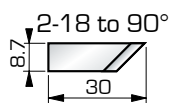

Cutting blades

Blade for inner chamfering device *Slim Line*

0° cutting angle for device model :	Ch.60° HSS	Ch.90° HSS	Ch.90° Carbide
3 - 19	03-312	03-322	
10 - 30	03-302	03-321	
4 - 42		03-352	01-351

14° cutting angle for device model :	Ch.60° HSS	Ch.90° HSS
3 - 19	03-310	03-320
10 - 30	03-305	03-300
4 - 42		03-350

20° cutting angle for device model :	Ch.60° HSS	Ch.90° HSS
3 - 19	03-313	03-323
10 - 30	03-308	03-328
4 - 42		03-358

25° cutting angle for device model :	Ch.60° HSS	Ch.90° HSS
3 - 19	03-314	03-324
10 - 30	03-309	03-329
4 - 42		03-359

Devices
page 82

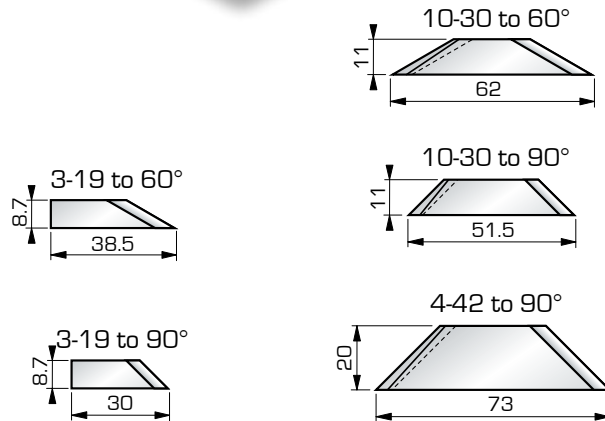

KOPAL

Material	Brass Bronze Cast iron Heat-resistant stainless steel	Steel Special bronze Perspex	Soft steel Copper AU 4 G Plastic Stainless steel	Aluminium Soft iron Sheet metal
Cutting angle	0° HSS Carbure	14° HSS	20° HSS	25° HSS

This devices works as a
carpenter's plane.

The output adjusting of the blade
controls the thickness of the chip
and not the value of the chamfer.

Ex. : blade output of 0.1mm
the device will make 10 turns
for cut 1mm chamfer.

Recommended cutting speed
between 10 and 20m/min.

exemple : Ø 10mm	320 to 640 rpm
Ø 15mm	210 to 420 rpm
Ø 20mm	160 to 320 rpm
Ø 30mm	110 to 220 rpm
Ø 40mm	80 to 160 rpm
Ø 60mm	55 to 110 rpm

$$Rpm = \frac{\text{cutting speed} \times 1000}{\text{Diameter} \times 3.14}$$

Devices
page 84

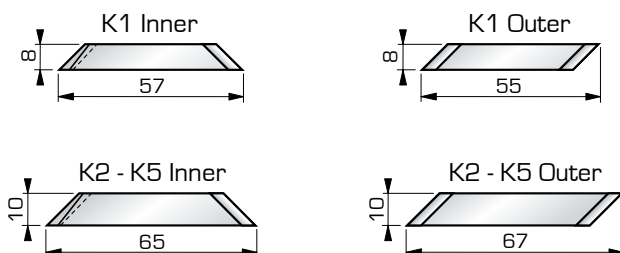

Blade for KOPAL Tube

14° cutting angle for device model :	Inner HSS	Outer HSS
K 1	04-300	04-310
K 2 to K 5	04-320	04-330

20° cutting angle for device model :	Inner HSS	Outer HSS
K 1	04-303	04-313
K 2 to K 5	04-323	04-333

CHAMFERING



KOPAL



Chamfering Carriers and Machines

KOPAL®



Chamfering carrier <i>Azimut</i>	90
Contouring carrier	91
Cutters and components	92
Electric Motor <i>RM 500</i> with flexible transmission	93
Machine for straight chamfer <i>LM 300</i>	94
Contouring machine <i>CM 300</i>	95

Chamfering carrier

- Chamfer consistency and quality
- Quick tool changeover
- Chamfering on straight or curved cutting edges

AZIMUT

For KOPAL Motor RM 500
with flexible transmission
ref. AZ0430 - AZ0431



AZIMUT EVOLUTION Including cutter

	capacity	Milling Cutter for all materials	Ref.
Chamfer	0.3 and 0.6 mm	Ø 3mm	AZ0212
	0.5 and 1 mm		AZ0210
	1 and 2 mm	Ø 6 mm	AZ0225
Radius	1 and 1.5 mm	Ø 9 mm	AZ0255

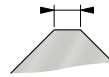

KOPAL

Motor and chamfering carrier supplied separately. 

Chamfer value on a flat surface

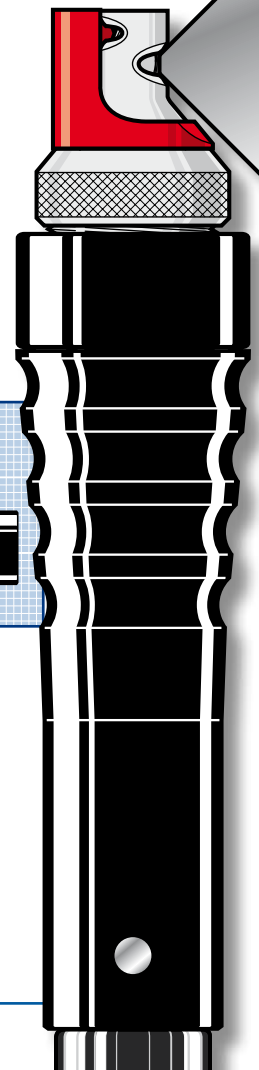

AZIMUT EVOLUTION [with quick coupling handle]

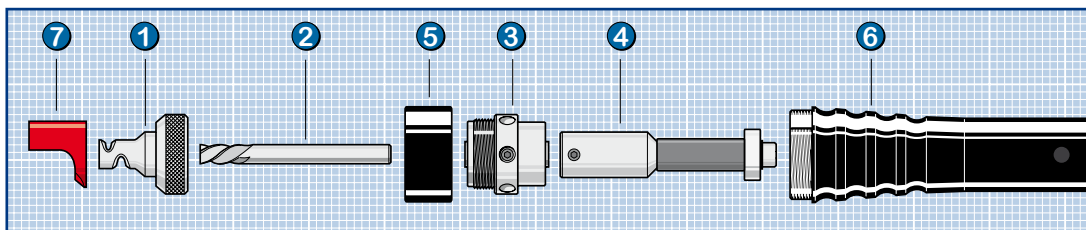

- 1 Interchangeable guide defining chamfer value
- 2 Carbide cutter, Ø 6mm shank
- 3 Carrier bearing (2 rolling bearings) : AZ-202
- 4 Cutter drive : AZ0305
- 5 Attachment ring : AZ0736
- 6 Quick coupling handle : AZ0310
- 7 Removable chip deflector

Scale : 1/1

90 KOPAL

CHAMFERING

Contouring carrier

- Precise and uniform chamfers
- Chamfering of complex inner and outer shapes

CONTOURING CARRIER Ref.

Complete carrier **AZ0070**
Including 45° carbide cutter and guide bearing Ø 9 mm

Spare parts Ref.

45° carbide cutter **AZ-660**

Guide bearing Ø 9 mm **AZ-714**

Other sizes of guide bearing page 92



For KOPAL Motor
with flexible transmission
RM 500 ref. AZ0430 - AZ0431

Principle

The cutter, driven directly by the flexible coupling, rotates inside a rolling bearing. The opening width of the guide placed on this bearing defines the chamfer or radius value to be performed. The cutter can be replaced after wear and tear.

Motor and chamfering carrier supplied separately.



Adjustment

Turn the support ring to change the chamfer value
chamfers 0 to 2mm

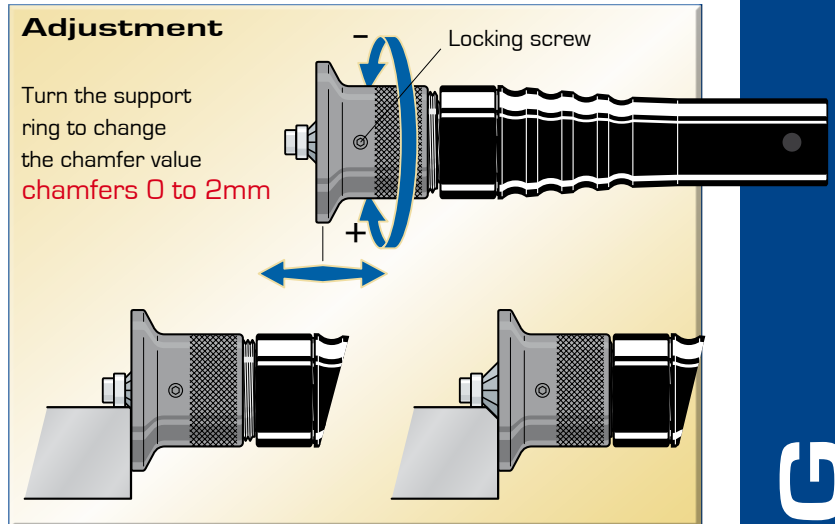

CONTOURING CARRIER

(with quick coupling handle)

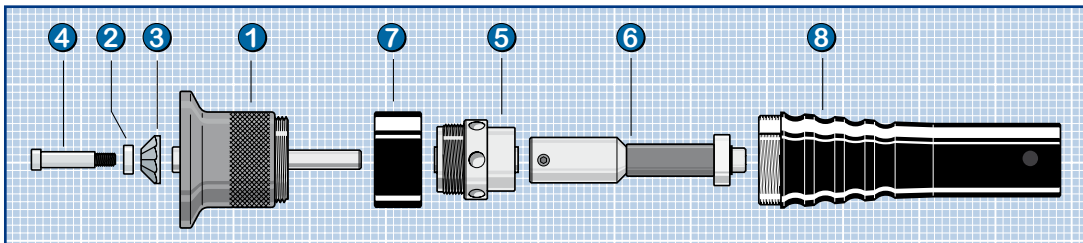

- 1 Contouring head
- 2 Guide bearing Ø 9mm : AZ-714
- 3 Carbide cutter : AZ-660
- 4 Centring screw for cutter : AZ-748
- 5 Carrier bearing [2 rolling bearings] : AZ-202
- 6 Cutter drive : AZ0305
- 7 Attachment ring : AZ0736
- 8 Quick coupling handle : AZ0310







KOPAL 91

Cutters and components

Guide





All Azimut models

Chamfer		Ref.
0.3 and 0.6		AZ-512
0.5 and 1		AZ-510
1 and 2		AZ-520

Radius		Ref.
1 and 1.5		AZ-545

Carbide cutters for all materials

All Azimut models

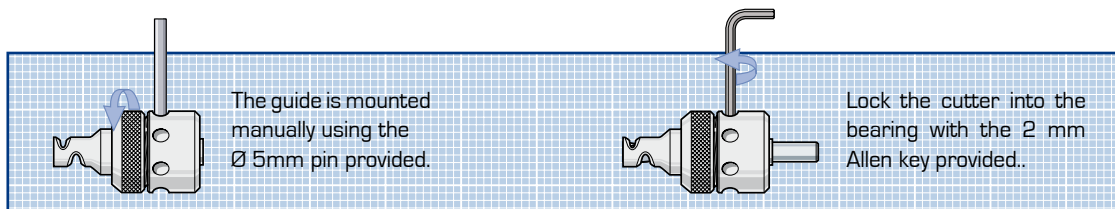

Chamfer		Ref.
0.3 and 0.6	$\varnothing 3 / 3$ teeth 	AZ-610
0.5 and 1	$\varnothing 3 / 3$ teeth 	AZ-610
1 and 2	$\varnothing 6 / 4$ teeth 	AZ-625
Radius		Ref.
1 and 1.5	$\varnothing 9 / 6$ teeth 	AZ-645

Carbide cutters, left helix, $\varnothing 6$ attach. 60 length







KOPAL

Protection

Chip deflector		Ref.
for Azimut Ch. 0.3 to 2mm		AZ-595
for Azimut Radius 1 to 1.5		AZ-596



Components

Contouring carrier and machine

Carbide cutter		Ref.
$\varnothing 15 - 90^\circ$		AZ-660
Guide bearing		Ref.
$\varnothing 8$		AZ-713
$\varnothing 9$		AZ-714
$\varnothing 10$		AZ-717
$\varnothing 11$		AZ-718

Components

Azimut Evolution, chamfering, Contouring

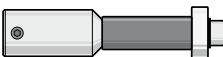
Carrier (double bearing)		Ref.
$\varnothing 25$ mm		AZ-202
Aluminium quick coupling handle		AZ0310
Knurled attachment ring		AZ0736
Cutter drive		AZ0305



Chamfering Machine

Motor with flexible transmission



RM 500

**Motor and carrier
supplied separately**

- Noise-reducing flexible coupling
- Quick changeover with Azimut tools

Machine RM 500 Ref.

including : Motor 500 W
and 1.2 meter of flexible length

Motor 230 V (Europe plug) **AZ0430**

Motor 110 V (US - Asia plug) **AZ0431**

Spare parts Ref.

Complete transmission 1.2 m AZ0505

Cable drive (inner part) AZ0515

Can be used with

Chamfering and contouring carrier
0.3 up to 2 mm chamfers - page 90 - 91

Collet carrier AZ0350
with \varnothing 6 mm collet

The transmission unit is designed to work with KOPAL chamfering carriers.

It can be equipped with various accessories for sanding, polishing, engraving, etc...



Chamfering carrier

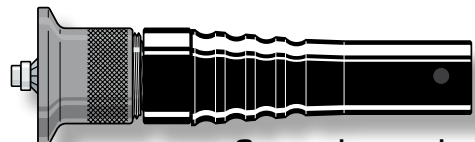

Contouring carrier



Collet carrier



Technical data :

Motor 500 W
110 V or 230 V.

Speed rotation
11000 to 25000 rpm

Weight : 2.3 kg

flexible transmission : 1.2 meter



Flexible rapid coupling :

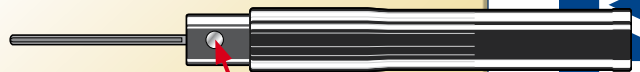

Press the locking axis
Put the carrier
= 5 secondes

Chamfering Machine

LM 300

Two steel base plates ensure that the workpieces to be chamfered are correctly guided and simplify the adjustment of the chamfer value..

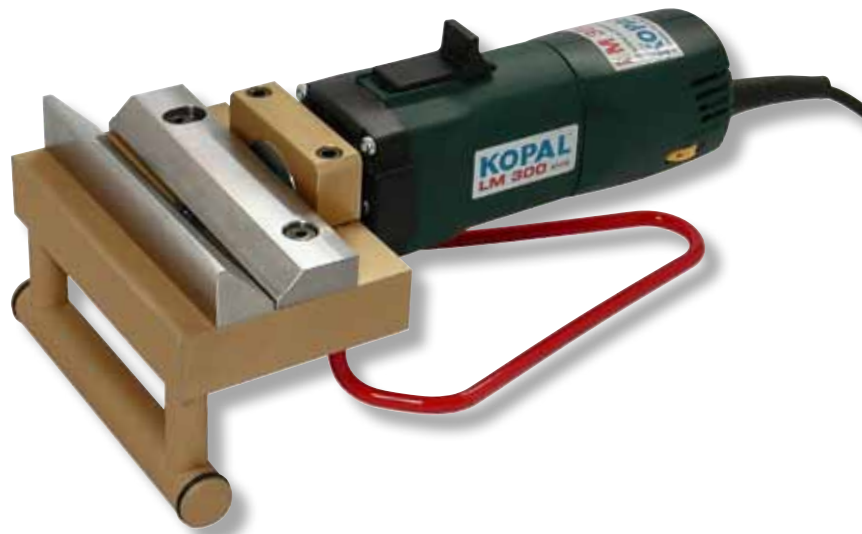

Machine LM 300 Ref. **AZ-415**
including :

- 1 Carbide cutter Ø 6 x 47 mm
- 1 Ø 6 mm collet

Spare parts and Optional components Ref.

Carbide cutter : Ø 6 x 47 mm	AZ-627
Ø 6 mm collet	AZ-947

- Portable or workbench use
- Long cutter service-life

Technical data :
Chamfer : 0 to 2 mm
 Carbide cutter : Ø 6mm
 Motor : 710 W - 230 V.
 Speed rotation
 10000 to 27000 tr/min
 Weight : 4 kg
 length of guide : 150 mm

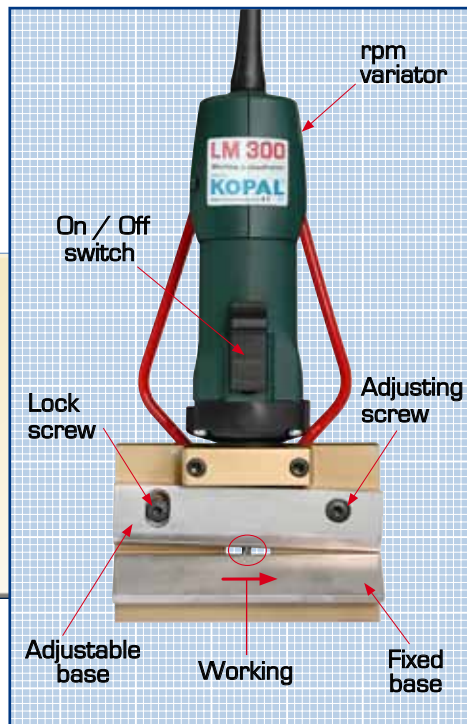

KOPAL

Chamfer adjustment :

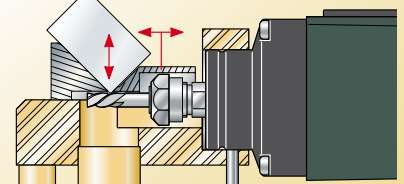

Move the position of the adjustable base for change the value of the chamfer.

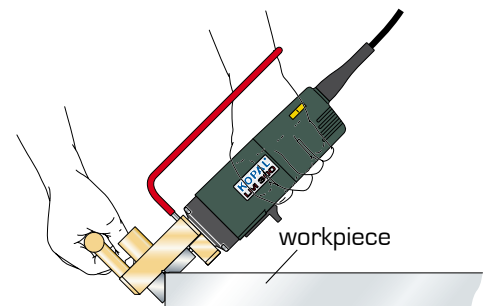
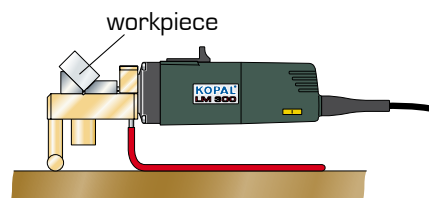

CHAMFERING

Chamfering Machine

CM 300



Machine CM 300 Ref.
AZ-420

including :
 1 x 45° Carbide cutter, 1 Ball bearing Ø 9 mm
 1 x Protection screen 190 x 250
 1 x Chip aspiration (Venturi system)

Spare parts and Optional components Ref.

Carbide cutter : 45° Ø 15 AZ-660
 Double carbide cutter : 45° AZ-658
 Contouring carbide cutter AZ-670
Ø 9 Ball bearing AZ-714
Other sizes of guide bearing page 92
Bar guide AZ-422

KOPAL



Technical data :
 Chamfer : 0 to 2 mm
 Carbide cutter : 45°
 Motor : 710 W - 230 V.
 Speed rotation
 10000 à 27000 tr/min
 Weight : 15 kg
 Table : 280 x 240 mm,
 Table height : 330 mm

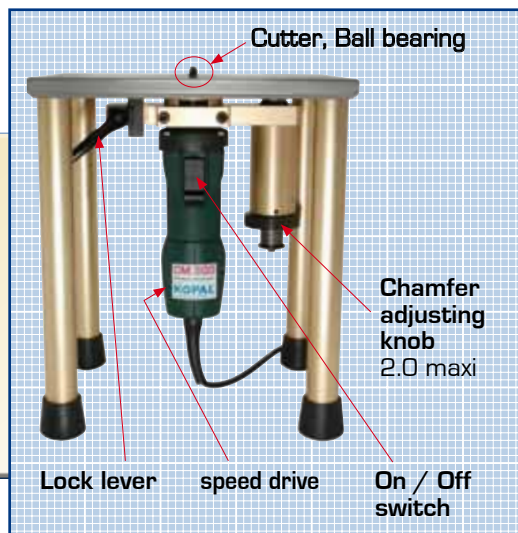

Chamfer adjustment :

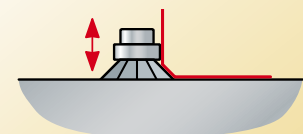

Release the lever
 turn the adjusting knob
 1 mark = 0.2 mm.
 Block the lever

For straight workpieces or thin sheet metal.

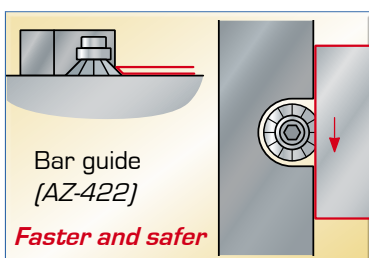

For all type of workpieces.

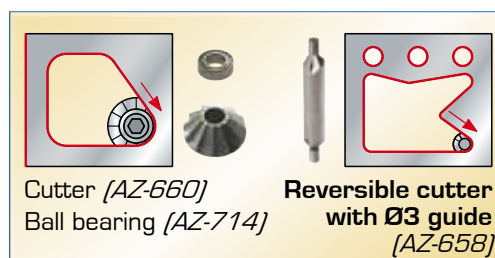

For pieces with complex shapes.

Reversible cutter with Ø3 guide (AZ-658)

Workpieces contouring

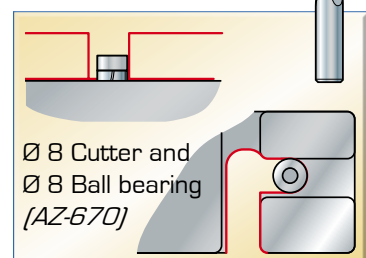

CHAMFERING



KOPAL





Hooks, Pincers and Cutters for chips



KOPAL



Chip Hooks	98
Pincers and Cutters for chips	99

Chip Hooks



Safety

A work-related accident can happen very easily.

Always use a chip hook to clear away annoying chips and empty the chip trays on your machines.

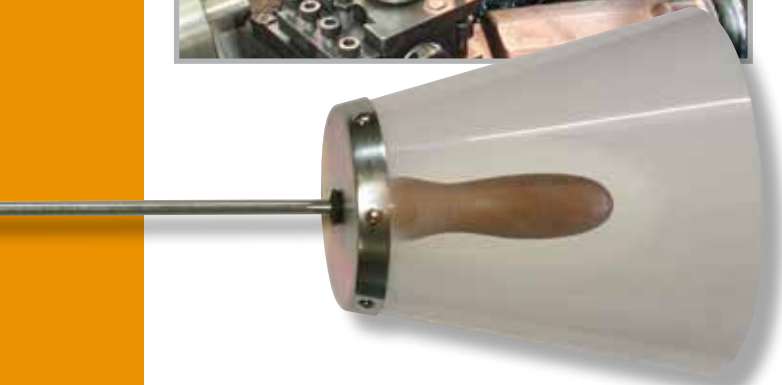

Traditional hooks

Model	Ø	A	B	C	D	Ref.
A	5	180	125	305	130	12-020
B	6	300	130	410	130	12-030
C	6	400	130	530	130	12-040
C*	6	400	130	530	130	12-050
C+*	6	550	130	680	130	12-051

Brazed-soldered guard plate on model C* and C+*

Hooks with protecting hilt single handle (held in one hand)

Model	Ø	A	B	C	D	Ref.
D	6	400	180	570	180	12-060
E	7	500	180	670	180	12-070

Flexible mounted guard

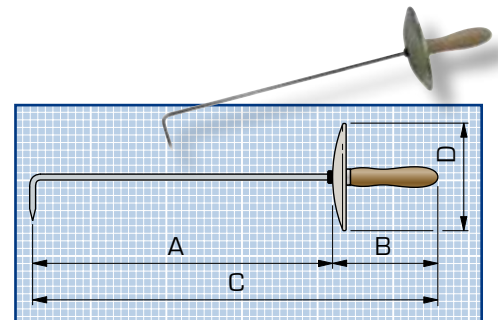
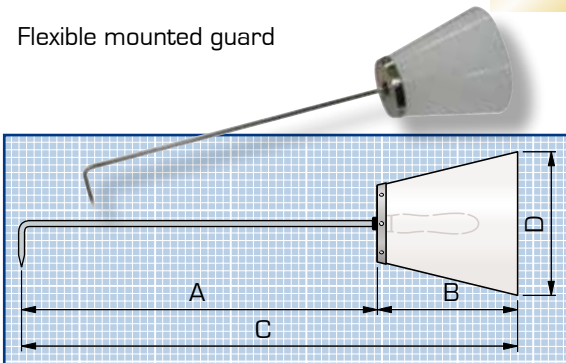

Hooks with protecting hilt double handle (held in two hands)

Model	Ø	A	B	C	D	Ref.
F	7	500	320	820	180	12-080
G	8	800	320	1120	180	12-090
H	8	1000	320	1320	180	12-100

Flexible mounted guard

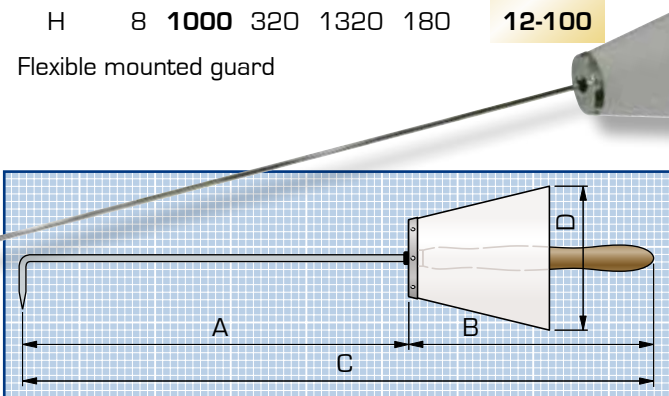

Metal protective guard plate or polyethylene protecting hilt. The wooden handles ensure a firm grip.

Chromated galvanised steel rods

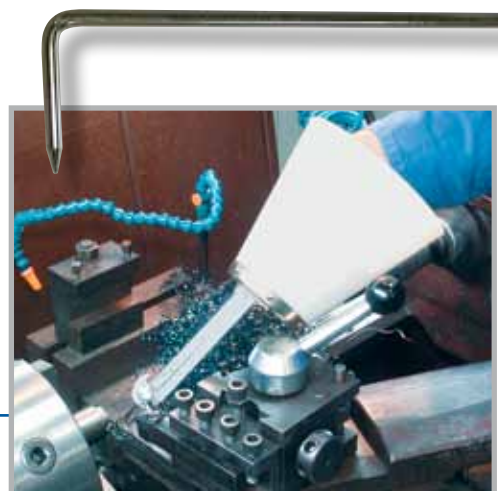
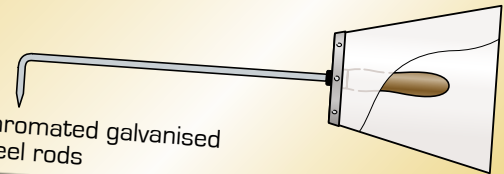

Pincers and Cutters for chips

Due to their high clamping force, the cutters and pincers make it possible to cut chips and to clean tools in complete safety.

They are available with a square-shaped aluminium protection plate or with a polyethylene protecting hilt, for complete hand protection.

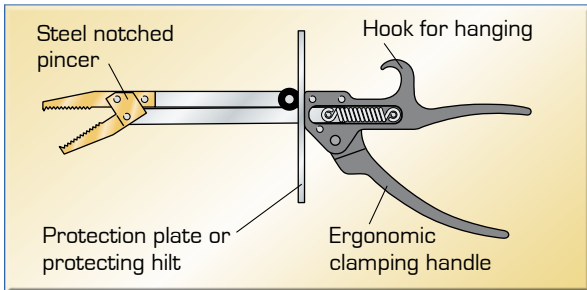
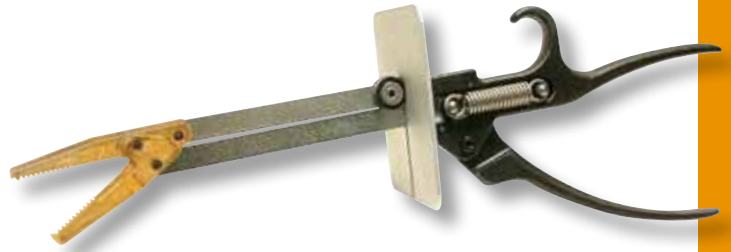

Chip pincers

For powerful grip and chip handling.

A	B	C	D	Ref.
175	85 x 85	330	155	11-025
With aluminium protection plate				
175	∅ 180	355	180	11-035
With protecting hilt				

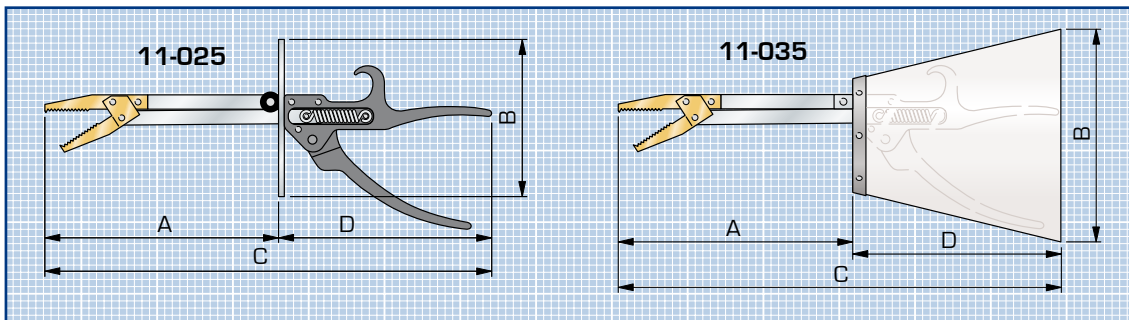

Chip cutters

For chip cutting :
1.5 mm² maxi. (ex : 0.25 x 6 mm)

A	B	C	D	Ref.
165	85 x 85	320	155	11-050
With aluminium protection plate				
165	∅ 180	345	180	11-060

With protecting hilt



Safety

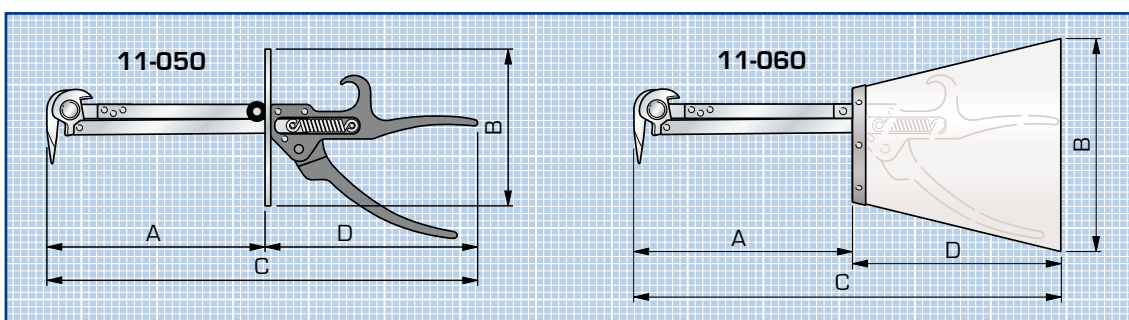
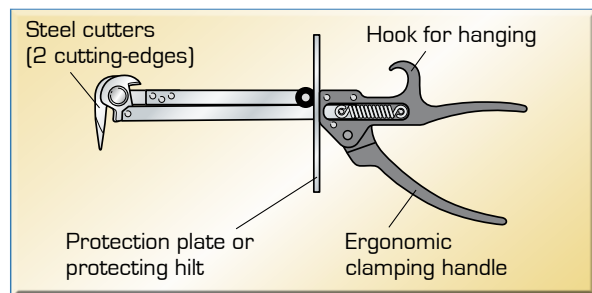



OFICJALNY PRZEDSTAWICIEL W
POLSCE : **RAIS-TOOLS**

**BUSZEWO 22
62-045 PNIOWY
POLSKA**

**TEL. +48 61 822 90 52
TEL. +48 698 684 211**

**www.rais.pl
biuro@rais.pl**



KOPAL



100 KOPAL

SAFETY