

BRAUER®

Durable by Design

WHEELS AND CASTORS

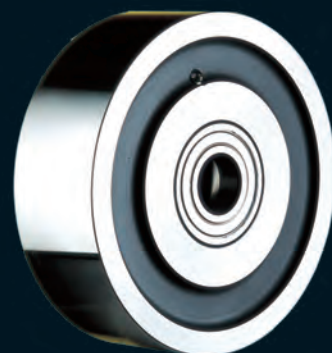
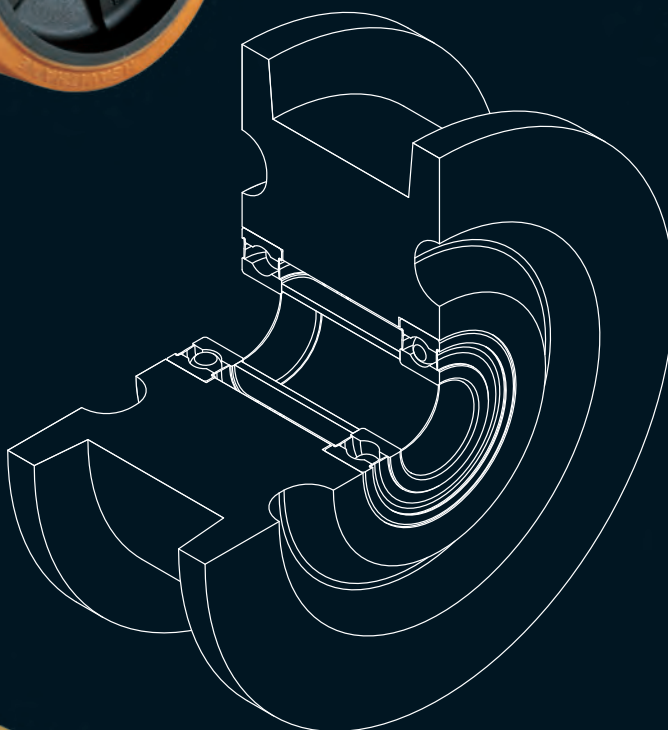

OFICJALNY PRZEDSTAWICIEL W
POLSCE : **RAIS-TOOLS**

BUSZEWO 22
62-045 PNIEWY
POLSKA

TEL. +48 61 822 90 52
TEL. +48 698 684 211

www.rais.pl
biuro@rais.pl

www.brauer.co.uk

Brauer Wheels and Castors was established in 1926 and for over 85 years has been designing and manufacturing the very best in quality wheels and castors in materials from nylon through to stainless steel. Today Brauer Wheels and Castors are found throughout the world in applications as industrially diverse as the nuclear industry to agricultural machinery.

Over the years we have developed the knowledge and expertise to help solve any wheel or castor related enquiries. Our design team is second to none in the design of wheels and castors to meet any requirement the customer may have. The skills inherent in our design engineering team are supported by the latest computer aided design facilities including 3 dimensional feature based parametric solid modelling and finite element analysis. These features ensure we maintain our pre-eminent position as the No 1 designer and manufacturer of industrial wheels and castors.

Durable by Design comes from the experience and support of our partners worldwide and internal and external engineers, you will see that when it comes to industrial wheels and castors there is only one company to be with.

Whether you require a standard catalogue item from stock, a simple non-standard version of a standard wheel/castor or a complete wheel and axle/castor assembly specially designed for your specific requirement, you can be sure that Brauer Wheels and Castors will meet your needs.



Heavithane is a registered trade mark of Brauer Ltd.

Brauer Ltd reserves the right to change the design or specification of the products shown in this catalogue without prior notification.

© Brauer Ltd

No part of this publication may be reproduced in any form (including photocopying or storing in any medium by electronic means) without the written permission of Brauer Ltd.

DESIGN SERVICE OUTLINE AND DATA

18 - 31

WHEELS & AXLE ASSEMBLIES

32 - 89



Steel Single Flanged Rail Wheels Page 33 - 35

Series 'SSF'
 Wheel Dia Ø75-600
 Load Range 975-30900Kg



Cast Iron Single Flanged Rail Wheels Page 36 - 38

Series 'CSF'
 Wheel Dia Ø63-300
 Load Range 200-2300Kg



Steel Double Flanged Rail Wheels Page 39 - 42

Series 'SDF'
 Wheel Dia Ø75-600
 Load Range 1350-30900Kg



Cast Iron Double Flanged Rail Wheels Page 43 - 44

Series 'CDF'
 Wheel Dia Ø130-300
 Load Range 650-2300Kg



Steel Flat Tread Rail Wheels Page 45 - 47

Series 'SFT'
 Wheel Dia Ø75-600
 Load Range 2300-46300Kg



Cast Iron Flat Tread Rail Wheels Page 48 - 49

Series 'CFT'
 Wheel Dia Ø130-300
 Load Range 1200-4000Kg



Cast Nylon Flat Tread Rail Wheels Page 50 - 51

Series 'NFT'
 Wheel Dia Ø200-400
 Load Range 2350-7850Kg



Cast Nylon Double Flanged Rail Wheels Page 52 - 53

Series 'NDF'
 Wheel Dia Ø200-400
 Load Range 1960-4770Kg



Steel 'V' Grooved Wheels Page 54 - 55

Series 'SVT'
 Wheel Dia Ø75-300
 Load Range 800-7100Kg



Polyurethane Tyred Single-flanged Rail Wheels Page 56 - 57

Series 'SFH'
 Wheel Dia Ø100-200
 Load Range 450-1400Kg

WHEELS & AXLE ASSEMBLIES (continued)

32 - 89



Single Flanged 'I' Beam & Channel Wheels - Flat Tread Page 58

Series 'SSFF'
 Wheel Dia Ø55-200
 Load Range 370-2000Kg



Single Flanged 'I' Beam & Channel Wheels - Radius Tread Page 59

Series 'SFR & SSFR'
 Wheel Dia Ø55-175
 Load Range 160-1500Kg

Rail Page 60 - 63



Cast Iron Untyred Wheels Page 64 - 67

Series 'C'
 Wheel Dia Ø75-350
 Load Range 400-5700Kg



Polyurethane Tyred Wheels Page 68 - 73

Series 'H'
 Wheel Dia Ø75-460
 Load Range 300-5200Kg



Guide Rollers Page 74 - 77

Series Vulkollan 90 & Vulkopan 59
 Wheel Dia Ø18-125
 Load Range 10-260Kg

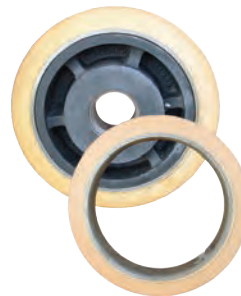

Polyurethane 'Press-On-Band' Tyred Wheels Page 78 - 81

Series 'PH'
 Wheel Dia Ø250-500
 Load Range 2000-4800Kg



Rubber Tyred Wheels Page 82 - 83

Series 'R'
 Wheel Dia Ø100-200
 Load Range 120-400Kg

WHEELS & AXLE ASSEMBLIES (continued)

32 - 89



Rubber Tyred 'Press-on Band' Page 84

Series 'PR'
Band Dia Range Ø380-460
Load Range 1240-1470Kg



Axle Brackets Page 86

Series 'B'
Load Range Up To 20000Kg



Twin Wheel Axle Assemblies Page 87

Series 'A'
Load Range Up To 12000Kg



Single Wheel Axle Assemblies Page 88

Series 'BA'
Load Range Up To 40000Kg



Untyred Nylon Wheels Page 85

Series 'N'
Wheel Dia Ø50-250
Load Range 80-2000Kg



Cantilevered Stub Axle Assemblies Page 89

Series 'CA'
Wheel Dia Up To 1100Kg

AVAILABLE ADDITIONS TO STANDARD SPECIFICATIONS

H7 TOLERANCE

GRUB SCREWS

ANTI-HYDROLYSIS TO POLYURETHANE

FLAT TREAD OPTIONS

THROUGH AXLE GREASE (TAG)

CROWN TREAD ON POLY WHEELS

FLAME HARDENING

INDUSTRIAL CASTORS

90 - 112



Pivoting Castors Page 91

Designed to Order
Load Range Up to and exceeding 200 Tonne



Pneumatic Tyred Castor Single Wheel Page 92

Series 'WG'
Wheel Dia Ø535
Load Range Up to 2100Kg



Pneumatic Tyred Castor Twin Wheel Page 93

Series 'TQZ'
Wheel Dia Ø535
Load Range Up to 4200Kg



UHQZ Series with Various Wheels Swivel load Rating 12000Kg Page 95

Series 'UHQZ'
Wheel Dia Ø350-500
Load Range 6400-12000Kg



HQZ Series with Various Wheels Swivel load Rating 7300Kg Page 96

Series 'HQZ'
Wheel Dia Ø200-380
Load Range 6200-7300Kg



TQZ Series with Various Wheels Swivel load Rating 5100Kg Page 97

Series 'TQZ'
Wheel Dia Ø200-300
Load Range 4000-5100Kg



QZ Series with Various Wheels Swivel load Rating 4200Kg Page 98

Series 'QZ'
Wheel Dia Ø200-380
Load Range 3100-4200Kg



TWG Series with Various Wheels Swivel load Rating 3000Kg Page 99

Series 'TWG'
Wheel Dia Ø150
Load Range 1200 -3000Kg



WG Series with Various Wheels Swivel load Rating 3000Kg Page 100

Series 'WG'
Wheel Dia Ø150-300
Load Range 900-3000Kg



GG Series with Various Wheels Swivel load Rating 1500Kg Page 101

Series 'GG'
Wheel Dia Ø100-250
Load Range 450-1500Kg

INDUSTRIAL CASTORS (continued)

90 - 112



LG Series with Polyurethane Tyred Wheel
Swivel load Rating 1000Kg Page 102
 Series 'LG'
 Wheel Dia Ø125-150
 Load Range 400-600Kg



H Series with Polyurethane Tyred Wheel
Swivel load Rating 1500Kg Page 103
 Series 'HS & HF'
 Wheel Dia Ø100-300
 Load Range 500-1500Kg



F Series with Polyurethane Tyred Wheel
Swivel load Rating 380Kg Page 104
 Series' 'FS' & 'FF'
 Wheel Dia Ø75-150
 Load Range 300-380Kg



E Series with Polyurethane Tyred Wheel
Swivel load Rating 380Kg Page 105 - 106
 Series' 'ES' & 'EF'
 Wheel Dia Ø76-200
 Load Range 100-380Kg



E Series with High Temperature Phenolic Wheel
Swivel load Rating 250Kg Page 107
 Series' 'ES' & 'EF'
 Wheel Dia Ø76-150
 Load Range 100-250Kg



600Kg Jacking Unit Page 108
 Series 'JBG'
 Wheel Dia Ø125-200
 Load Range Up to 600Kg



1000Kg Jacking Unit Page 109
 Series 'JGG'
 Wheel Dia Ø100-250
 Load Range Up to 1000Kg



1600Kg Jacking Unit Page 110
 Series 'JMG'
 Wheel Dia Ø150-300
 Load Range Up to 1600Kg



2500Kg Jacking Unit Page 111
 Series 'JWG'
 Wheel Dia Ø150-300
 Load Range Up to 2500Kg



Floor Locks Page 112
 Series 'FL'
 Wheel Dia Ø100-150

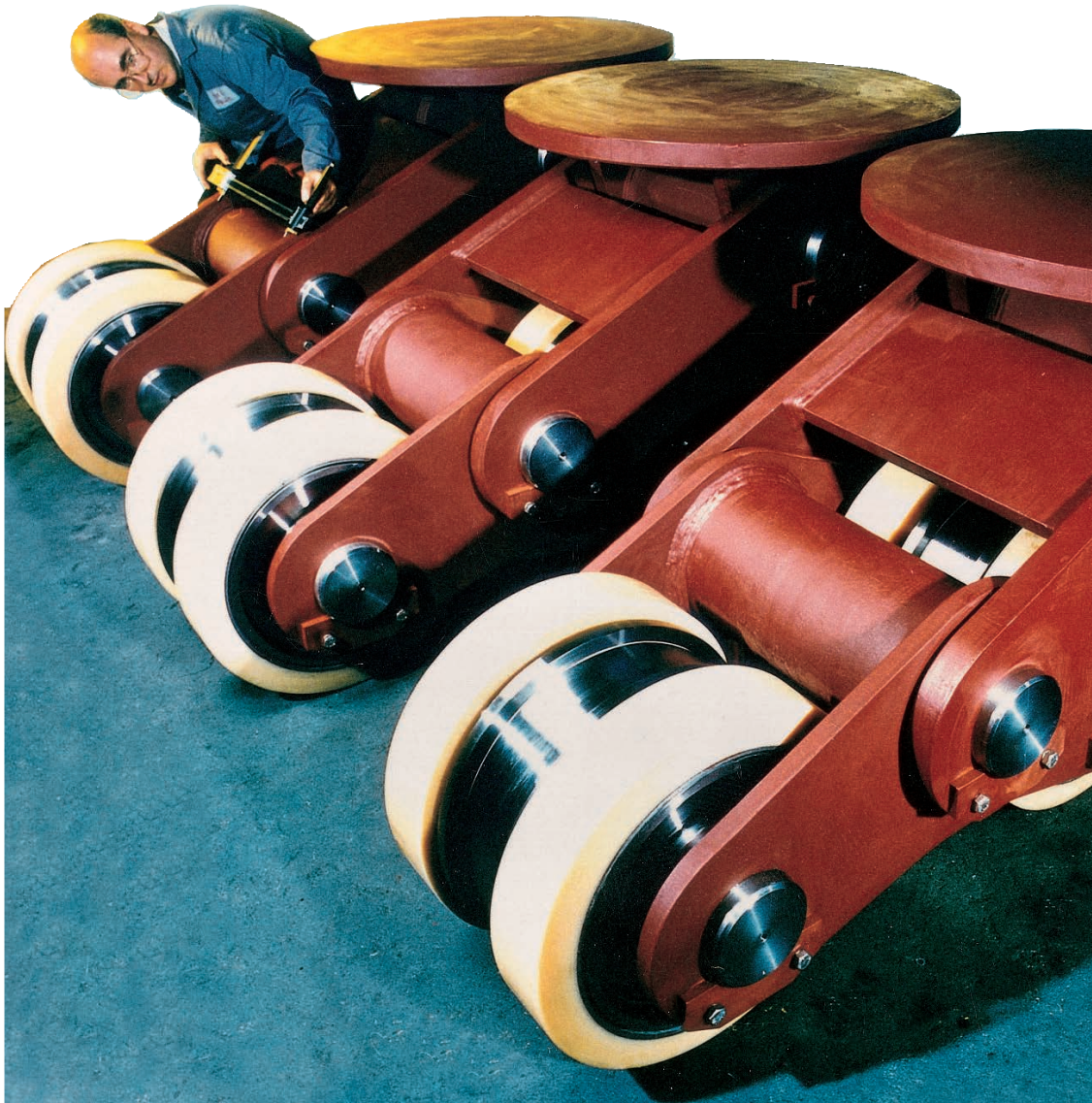

Applications and Examples

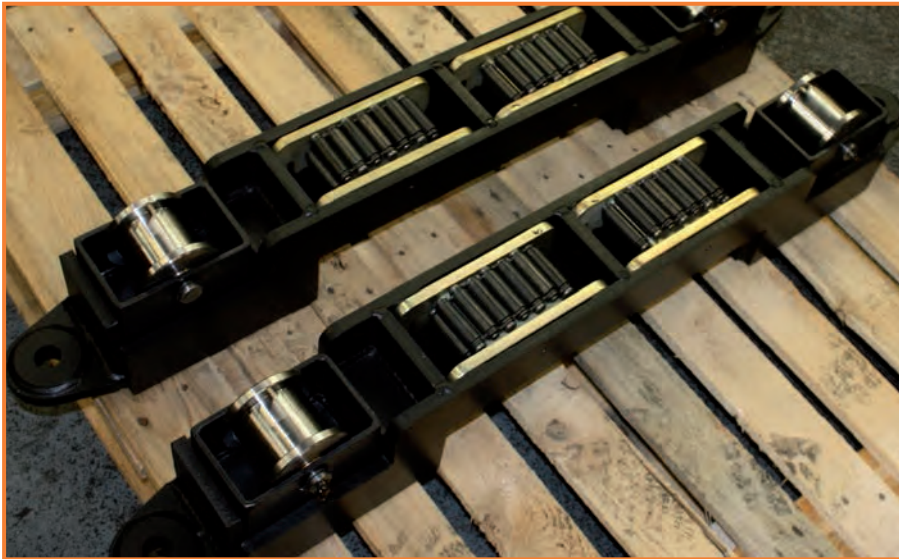

Brauer Ltd manufactured according to the design specification of J Murphy and Sons Limited, Gas pipe tunnel trollies for the gas ring main improvement to the west of London from Harefield to Southall for the National Grid.

The gas pipe is required to be push/pulled into position and statically supported whilst empty (565kg/m), until the tunnel annulus is filled, the trollies must also support the pipe when filled with water to support hydro testing (1735kg/m)

The 4 sections of the tunnel have lengths of 974m, 756m, 505m and 207m respectively and the total improvement section is 27 kilometres



The bored tunnel of concrete section was 2.2m diameter and the gas pipe within this tunnel was 1.2m diameter leaving very limited space between the two, so the gas pipe supporting trollies had to be small enough to enter this gap between the pipe and the tunnels walls but have very high loading capacity to take the gas pipe as it was pulled/pushed into the outer tunnel. The rail system for the trollies was laid on a bed of silicon sand.

Brauer Ltd provided a total solution of 88 low height / high load capacity trollies which ranged from 10,000Kg each to 22,000Kg each.

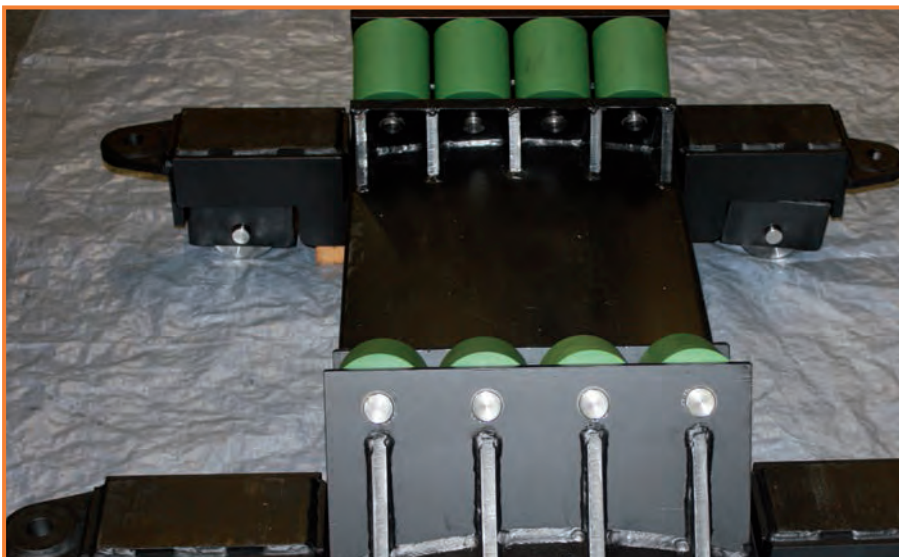



7600 tonne, 32 meter diameter, pipe laying turntable running on 330 steel double flange rail wheels fitted with self-lubricating bushes and stainless steel shafts.
Tread diameter 450mm.
Tread width 112mm wide with crown profile to assist tracking.
Tread and inner flange flame hardened to ensure a service wear life in excess of seven years.



Applications and Examples

BRAUER[®]



Ship mounted cable and pipe carousels used in the offshore wind farm, renewable energy and energy supply industries loaded capacities between 2,500 tonnes to 15,000 tonnes



This ship mounted pipe laying turntable which is running on three rings of tapered tread steel wheels mounted in a fixed frame. The wheels and frame are finished in marine specification paint. Total weight when loaded is 600 tonnes with each wheel and bracket capable of carrying 50 tonnes.

APPLICATIONS AND EXAMPLES



A ship lift and transfer dock system for removing ships from the sea and then transferring ships around the dock for repair and maintenance to take place. Three sizes of wheels are used throughout the dock.

Rated Load

SDF 450/95/TBM75FH + AXLE	25500 Kg
SDF 350/85/TBM75FH + AXLE	19500 Kg
SDF 250/80/TBM50FH + AXLE	13000 Kg

FH = Flame Hardened

The SDF 250 and 350 being primarily used on the ship lift trolley with the SDF 450 mainly on the transfer system. The wheels have been simplified and redesigned to ensure longer life, easier installation and lower maintenance.



Applications and Examples



Multi-pivoting, dual purpose castor with directional swivel top plate. Fitted with 4 steel double flange rail wheels, 450mm tread diameter and 90mm tread width and 8 anti-hydrolysis polyurethane tyred wheels, 505mm tread diameter and 150mm tread width. All axles are ground stainless steel running in self lubricating nylon bushes.

Load Rating

- a) When mounted on rail and running on the double flange wheels – 160 tonne per castor assembly.
- b) When running on polyurethane tyred wheels – 76.8 tonne per castor assembly.



Wheel and axle assemblies used in a rotating drum application. Given the extreme conditions and high loadings involved the wheels and axles have been specifically designed to the customers requirements that demand flat tread wheels with axles that are capable of taking a load in excess of 75 tonnes.

The wheels shown are SFT600/250/KM150 with an axle Ø150mm reducing to 100mm for the bearing housing.



APPLICATIONS AND EXAMPLES

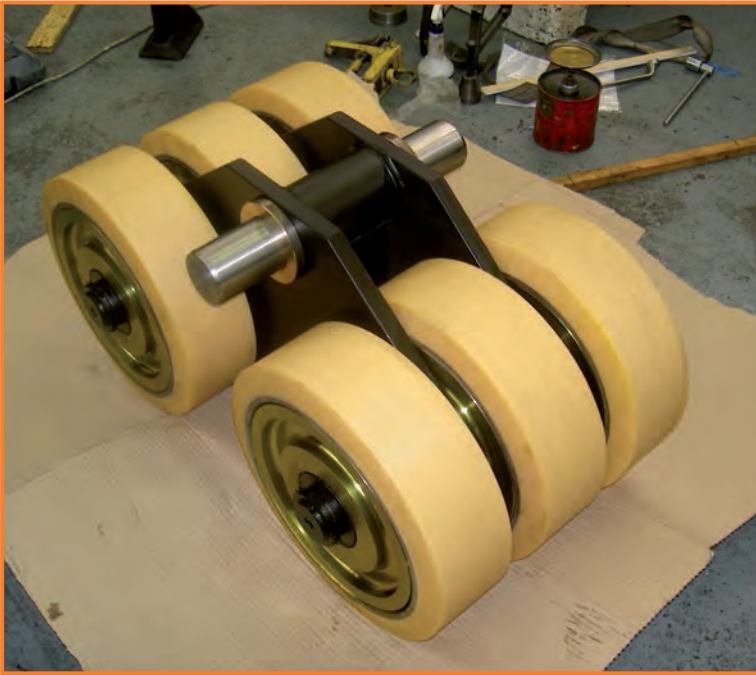

These special 28 tonne and 42 tonne pivot castors were designed to be used on 115 tonne capacity electro-mechanically controlled Portal Stands

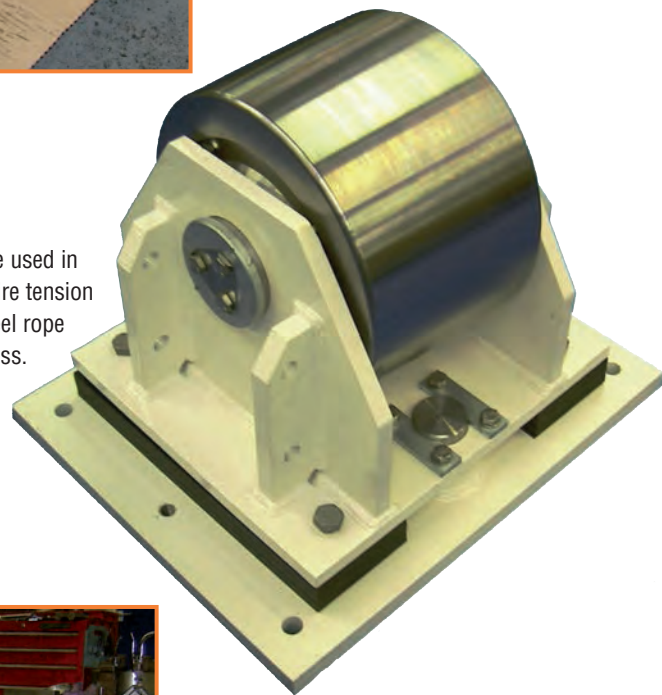

The portal stands are used in the support of the wire tension cable as part of a steel rope manufacturing process.



The machines to carry out this process were manufactured in England and then exported to the Steel Wire Rope and Tension Cable Manufacturing company in Scandinavia.

Applications and Examples



Access Gantry on Severn Bridge



Polyurethane tyred drive wheel. Tread diameter 500mm. Tread width 100mm.

Maximum radial load capacity 50KN. Tyre 95-98 Shore 'A' hardness directly bonded to aluminium grade BS1471-6082 - T6 centre to significantly reduce the weight for ease of handling. Aluminium anodised to prevent corrosion. Stainless steel hub bored and keywayed with interface between stainless steel hub and aluminium centre coated to prevent electrolytic action.



Access Gantry on Second Severn Bridge



Polyurethane tyred wheel fitted with spherical roller bearings. Tread diameter 500mm. Tread width 100mm. Maximum radial load capacity 50KN. Tyre 95-98 Shore 'A' hardness directly bonded to aluminium grade BS1471-6082-T6 centre to significantly reduce the weight for ease of handling. Aluminium anodised to prevent corrosion.

APPLICATIONS AND EXAMPLES

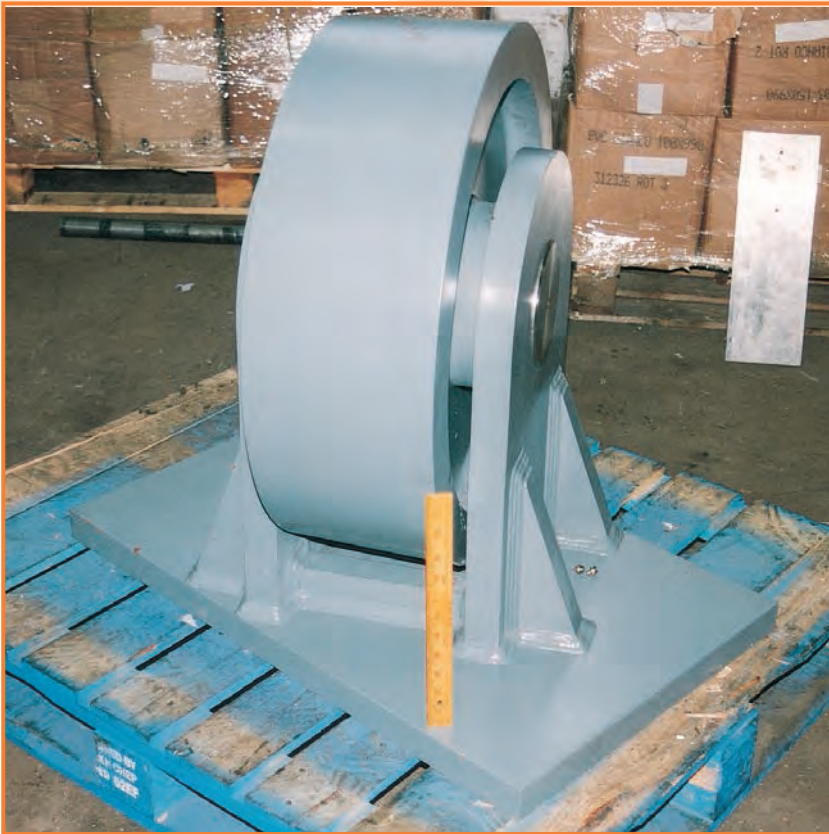

Swing bridge on Caledonian Canal at Fort Augustus



Fixed castor fitted with 686mm diameter EN24T steel wheel with composite PTFE bush running on ground stainless steel axle. Castor loading capacity 200 tonne.



Pivoting castor with swivel head fitted with two EN24T single flange rail wheels complete with wheel brakes.
Tread diameter 280mm.
Tread width 87.5mm.
Tread flame hardened.
Maximum load rating per castor 45000Kg.

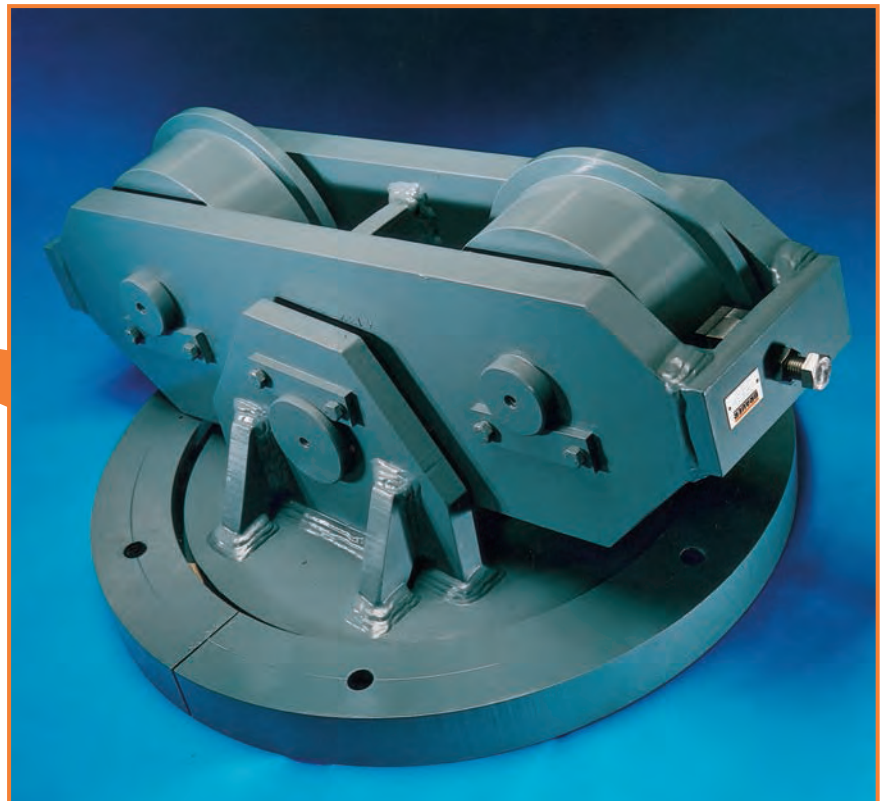

Applications and Examples



Bridge scraper for rectangular settlement tank

Steel double flange rail wheels SDF 450/80

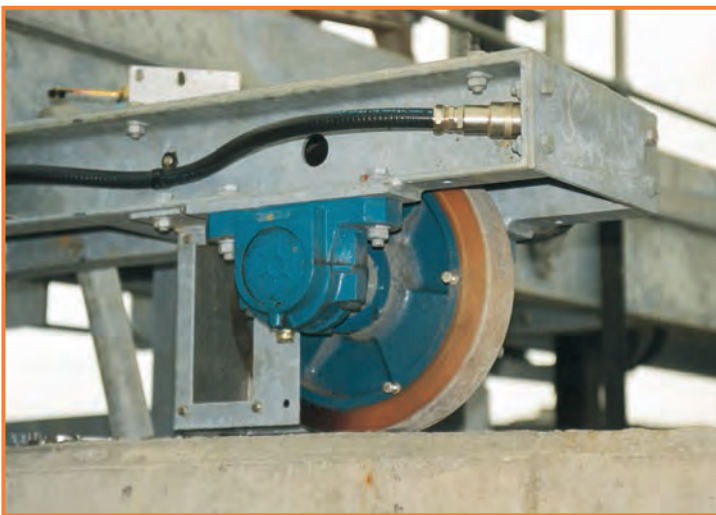
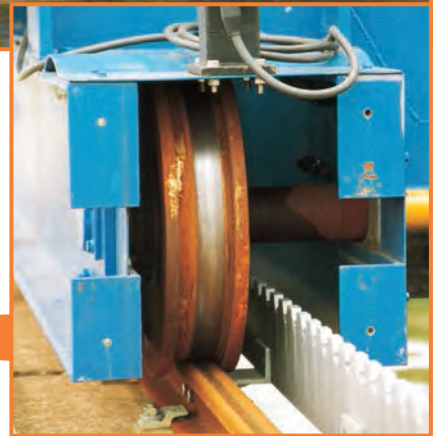

Half Bridge scraper for rotary settlement tank

Both drive and trailing wheels standard polyurethane tyred wheels H300/75 bored and keywayed.



APPLICATIONS AND EXAMPLES



Wheels and axles supplied for the maintenance of dryer transfer cars for brick manufacturing plant. Brauer supplied complete wheel and axle assemblies that comprised Steel Double Flanged and Steel Flat Tread Wheels.

In addition to the application shown Brauer have been instrumental in the replacement of wheels and ongoing maintenance of several other key areas of the plant. The solutions provided have helped to solve certain irritating problems and removed unnecessary downtime on the production line resulting in considerable savings to the company.



Aggregate Screening Machine

Drum supported on four twin wheel axle assemblies each consisting of two polyurethane 'Press-on-Band' tyred wheels PH460/75 fitted to a modified BA75 axle assembly



Drum supported on four pivoting castors each fitted with two polyurethane tyred wheels H200/60.





Wheel options of Cast Iron, Steel or Aluminium
Vulkollan superior polyurethane is used as the standard tyre material. Tyres can be produced with crown/dome treads to suit specific applications.
Bore options available for all standard wheels fitted with precision bearings.
Operating temperature range -20C° to +60C°.
Hardness of tyre of 92 ±3° shore 'A'.

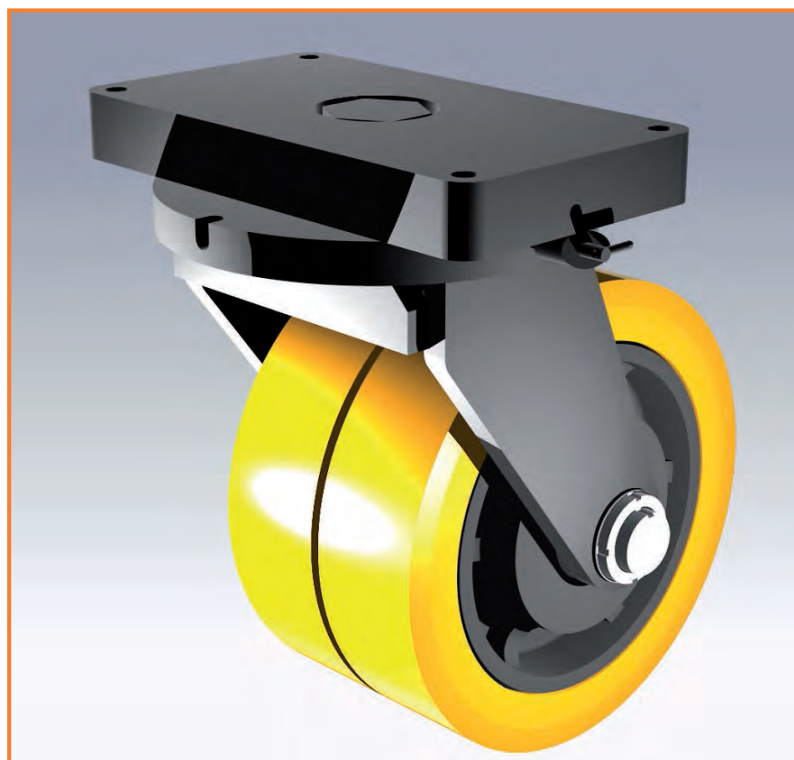

WHAT WE DO...



We offer a comprehensive design, engineering and manufacturing service to resolve your application problem either from our extensive range of standard products or products specifically designed for the application

- Wheels and castors designed to suit any environment.
- Computer aided design facilities include 3 dimensional feature based parametric solid modelling and finite element analysis.
- Life calculations for steel rail wheels.
- Non-standard wheels can often be designed from our extensive stock of castings, blanks, and part-machined and tyred wheels.
- Wheels, axle assemblies and castors can be designed and manufactured to suit any loading and in most materials including stainless steel, aluminium, titanium, nickel chromium alloys, etc.
- Polyurethane tyres can be bonded onto most metal centres including aluminium, titanium, stainless steel and various ferrous and non-ferrous alloys.
- Polyester/Polyether Polymeric tyre compounds can be produced in Naphthalene Diisocyanate (N.D.I), Toluene Diisocyanate (T.D.I) and Diphenylmethane Diisocyanate (M.D.I).
- All types of bearing and bushes can be incorporated into the design.
- Steel wheels and fabrications can be plated in blue or gold zinc passivation, cadmium, electroless nickel, chrome, etc. or finished to any paint specification.
- Non-destructive testing such as 'X' Ray, ultrasonic or magnetic particle detection is available on request.

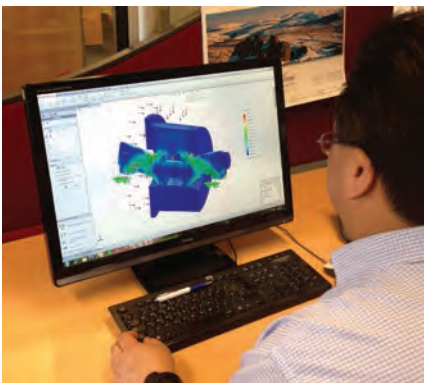

COPY, FILL IN AND SEND THE "APPLICATION DATA FORM" ON PAGE 19 OPPOSITE

Application Data Form

(use to get you started, or fill it in and send it back to us)



NAME: _____ POSITION IN COMPANY: _____

COMPANY NAME AND ADDRESS: _____

TELEPHONE NO. _____ FAX NO. _____ EMAIL _____

Application			
Description of application	_____		
No. of wheels per assembly	_____		
Total weight of assembly		_____ Kg	
Is the load evenly distributed	_____		
Radial load per wheel		_____ Kg	
Axial load per wheel		_____ Kg	
Function of wheel	Driving _____	Steering _____	Supporting _____
Running Surface	Concrete _____	Tarmac _____	Steel Plate _____
	Rail _____	Other (specify) _____	
Rail type		Useable rail width _____	mm _____
Speed of wheel	_____ rpm		
Frequency of use	(hour per day) _____	(cycles per day) _____	
Service life required	_____ hours		
Environment	Temperature _____ deg C	Dusty _____	Humid _____ %
	(if over 110 deg C see below)		
	Immersed in water _____	Other (specify) _____	
Rotating Drum			
Drum mass	_____ Kg		
Charge mass	_____ Kg		
Drum diameter	_____ mm		
Drum Speed	_____ rpm	_____ Kph	
Wheel angle from vert C/L	_____ deg		
Wheel			
Style of wheel	Tyred _____	Flat tread _____	Single flange _____
	Double flange _____		
Wheel dimensions	Tread dia _____ mm	Tread width _____ mm	Hub width _____
	Axle dia _____		
Wheel material	Carbon or alloy steel _____	Cast Iron _____	Stainless Steel _____
	Other (specify) _____		
Finish	Steel (air dry oil) _____	Cast Iron (black etch primer) _____	
	Other (specify) _____		
Bore			
Diameter	_____ mm		
Bearing requirements	Bearing _____	Bush _____	Brauer to define _____
Bearing type	Ball _____	Taper roller _____	Plain bore _____
	Sealed _____	Other (specify) _____	Spherical roller _____
Bush type	Plain bronze _____	Self lub. _____	Nylon _____
	Other (specify) _____		
Greasing requirement	Through wheel _____	Through axle _____	Sealed for life _____
	None _____		
Axle			
Are axle or axle brackets required?			
Axle type	'A' style _____	'BA' style _____	'CA' style _____
	'SFR' style _____	'Castor' style _____	Other (specify) _____
Axle material	Standard (En16 type) _____	Other (specify) _____	
Castor			
Is a castor assembly required?	_____		
Castor type? (specify)	_____		
Top plate flatness		_____	
Finish		Fabrication (black etch primer) _____	
High Temperature Application			
Where the working temperature is to exceed 110 deg C, the following data should be provided.			
Type of bearing required	Plain bearing (bush) _____	Flanged bush _____	Ball bearing _____
Maximum working temp		_____ deg C	
Is the wheel working (rotating) at this temperature under full load?			
Does the wheel work at a lower temperature, but remains static under load at max temperature?			
What period of time does the wheel remain under load at the maximum temperature?			
Maintenance Free?	_____	Grease Free? _____	

APPLICATION DATA FORM

Contents

1.0	Specification For Standard Wheels & Castors.....	21
2.0	Untyred Wheels.....	21
3.0	Rubber Tyred Wheels.....	21
3.1	Load Rating.....	21
3.2	Resistance to Chemicals.....	21
4.0	Cast Nylon Wheels.....	22
4.1	Resistance to Chemicals.....	22
5.0	Polyurethane Tyred Wheels.....	22
5.1	Load Rating.....	22
5.2	Resistance to Chemicals.....	23
6.0	Rail Wheels.....	23
6.1	Approximation of Allowable Load (catalogue items).....	23
6.2	Calculation of Allowable Load - Steel and S.G. Iron Rail Wheels.....	24-25
6.3	Calculation of Allowable Load - Cast Iron Rail Wheels.....	26
6.4	Surface Hardening.....	26
6.5	Flange Strength.....	26
7.0	Bearing and Seal Arrangements - Non Standard.....	26
7.1	Selection of Bearings.....	26
7.2	Bearing Seals.....	27
8.0	Inertial and Rolling Resistance.....	27
8.1	Rolling Friction.....	27
8.2	Bearing Friction.....	28
8.3	Inertial Resistance.....	28
9.0	Traction - Coefficients of Friction.....	28
10.0	Load Calculations for Wheels Supporting and/or Driving Drums.....	28
11.0	Keyway Dimensions.....	29
12.0	Reference Tables and Conversion Factors.....	29
12.1	Steel Hardness / Tensile Strength.....	29
12.2	Tensile Strength of Heat Treated Steels.....	29
12.3	Useful Conversion Factors.....	29
13.0	Castors.....	30
13.1	Castor Arrangement.....	30-31
13.2	Load Rating.....	31
13.3	Manual Propulsion.....	31
13.4	Power Towing.....	31

Important Note

Whilst due care has been taken in compiling the following information, Brauer cannot guarantee its detailed accuracy, and will not accept responsibility for the results of use of any data which is subsequently found to be inaccurate.

1.0 Specification For Standard Wheels & Castors

1. Plain bore tolerances are +0.05 / -0 mm.
2. Standard tolerances on width and diameter ± 0.25 mm except tyred wheels which are ± 1.00 mm.
3. Wheels are fitted with grease nipples, other than plain bore keywayed wheels, nylon centred wheels, or wheels of 75, 100 or 125 diameter. Wheels fitted with ball journal bearings up to 40 mm bore may be without grease nipples if fitted with double shielded bearings.
4. Wheels of 75, 100 or 125 diameter fitted with ball journal bearings have pre-lubricated shielded bearings.
5. All wheels supplied with ball journals, other than those of 75, 100 or 125 diameter, have bearings with a single shield fitted to the outer side unless otherwise stated. Wheels fitted with ball journal bearings up to 40 mm bore may be fitted with double shielded bearings.
6. All wheels with ball or roller bearings, other than those fitted with pre-lubricated double shielded ball journals, are supplied un-greased to avoid contamination during shipment.
7. All wheels fitted with ball journals have a central spacer between the bearings to allow them to be clamped to an axle abutment shoulder without pre-loading the bearings.
8. Taper roller bearings are supplied with the outer race (cup) press fitted, and the inner cone and roller assembly, together with metal shields, supplied loose.
9. All cast wheels are finished in one coat self-etching black primer paint.
10. Fully machined wheels or axles from billet, or barstock, are protected by a coat of air-drying oil.
11. Pressed steel castor brackets are finished in bright zinc electroplating to BS1706.
12. Fabricated castor brackets are finished in one coat of self-etching black primer paint.
13. Keyways are produced to Wheels in house standard tolerances.

2.0 Untyred Wheels

When less than the full tread width is used to carry the load, the allowable load can be determined as follows:-

$$\text{Allowable load} = \frac{\text{Load carrying width}}{\text{Full tread width (per catalogue)}} \times \text{'Maximum Load Rating' (per catalogue)}$$

3.0 Rubber Tyred Wheels

3.1 LOAD RATING.

The 'Maximum Load Rating' given for each rubber tyred wheel is the maximum load the wheel will carry in constant use under the following conditions:

- | | |
|---|--|
| a) the wheel is free-wheeling (not driving) | d) the surface on which the wheel runs is flat and smooth (i.e steel or smooth concrete) |
| b) the ambient temperature is below 30 degrees C. | e) that the wheel is not steering or subjected to axial loads |
| c) the surface speed does not exceed 6 kph | f) no chemical is present which will attack rubber (see 3.2) |

For more severe conditions than those described above refer to Brauer for the allowable load, or consider polyurethane tyred wheels.

3.2 RESISTANCE TO CHEMICALS

A = little or no effect
B = moderate effect
C = severe effect

Acetic Acid 20%	C	Formaldehyde	C	Mineral oils	C
Acetone	C	Formic acid	B	Naphtha	C
Ammonium hydroxide	C	Fuel oil	C	Naphthalene	C
Barium hydroxide	B	Gasoline	C	Nitric acid	C
Benzene	C	Glue	B	Oil - lubricating	C
Borax	A	Hydraulic oils	C	Palmic acid	C
Boric Acid	A	Hydrochloric acid - cold	A	Perchlorethylene	C
Butane	C	Hydrochloric acid - 10%	A	Phenol	C
Calcium bisulphite	C	Hydrochloric acid - hot	C	Phosphoric acid 85%	A
Calcium chloride	A	Hydrochloric acid - 30% +	C	Sodium hydroxide	C
Calcium hydroxide	B	Hydrogen	B	Soybean oil	C
Carbon dioxide	A	Isopropyl ether	C	Sulphuric acid 10%	A
Carbon monoxide	C	JP- 3	C	Sulphuric acid 50%	C
Carbon tetrachloride	C	JP -4	C	Tannic acid	A
Castor oil	B	Kerosene	C	Toluene	C
Chlorine	C	Linseed oil	C	Trichloroethylene	C
Chromic acid	C	Magnesium chloride	A	Turpentine	C
Cottonseed oil	C	Magnesium hydroxide	A	Water	A
Cyclohexane	C	Methyl alcohol	A	Xylene	C
Ethyl acetate	C	Methyl ethyl ketone	C	Zinc sulphate	A
Ethyl alcohol	A	Mercury	A		

4.0 Cast Nylon Wheels

4.1 RESISTANCE TO CHEMICALS

A = Excellent
 B = Good
 C = Fair
 D = Severe effect

Acetic Acid	D	Chromic Acid 10%	D	Naphtha	A
Acetone	A	Ethanol	A	Naphthalene	A
Acetyl Bromide	D	Ethyl Acetate	A	Nitric Acid (5-10%)	D
Alcohols:Butyl	D	Fluorine	D	Oils:Castor	A
Ammonium Hydroxide	A	Formaldehyde 100%	D	Oils:Creosote	D
Antifreeze	D	Formic Acid	D	Oils:Soybean	A
Asphalt	A	Fuel Oils	A	Ozone	D
Barium Hydroxide	A	Gasoline, leaded, ref.	A	Perchloroethylene	C
Beer	A	Glue, P.V.A.	A	Phenol (10%)	D
Benzene	A	Hydraulic Oil (Petro)	A	Sodium Hydroxide (50%)	A
Borax (Sodium Borate)	A	Hydrochloric Acid 20%	D	Sulfuric Acid (10-75%)	D
Boric Acid	B	Hydrogen Peroxide 10%	C	Tannic Acid	C
Butane	A	Jet Fuel (JP3, JP4, JP5)		Tetrachloroethylene	A
Calcium Chloride	A		C	Toluene (Toluol)	A
Calcium Hydroxide	A	Kerosene	A	Trichloroethylene	C
Calcium Sulfate	D	Lacquer Thinners	A	Water, Fresh	A
Carbon Dioxide (dry)	A	Magnesium Chloride	A	Water, Salt	A
Carbon Monoxide	A	Magnesium Hydroxide	B	Xylene	A
Chloric Acid	D	Methanol (Methyl Alcohol)	B	Zinc Sulfate	A
Chlorine Water	C	Motor oil	A		

5.0 Polyurethane (Vulkollan) Tyred Wheels

5.1 LOAD RATING AND FACTORS

The 'Maximum Load Rating' given for each polyurethane tyred wheel is the maximum load the wheel will carry in intermittent use (a maximum of 1 hour running followed by a minimum of 1 hour at rest) under the following conditions:

- a) the wheel is free-wheeling (not driving)
- b) the ambient temperature is below 45 degrees C
- c) the surface speed does not exceed 6 k.p.h.
- d) the surface on which the wheel runs is flat and smooth (i.e steel or smooth concrete)
- e) that the wheel is not steering or subjected to axial loads
- f) no chemical is present which will attack polyurethane (see 5.2)

For more severe conditions the 'Maximum Load Rating' must be multiplied by the 'Load factor' as follows:

Condition	Load Factor
Continuous running	0.75
Surface Speed 6-10 kph	0.8
Surface Speed 10-16 kph	0.7
Driving wheels	0.7

For speeds over 16 kph, for operating temperatures over 45 degrees C and below 20 degrees C, for humid conditions, and for curved running surfaces (i.e. in supporting rotating drums) refer to Brauer Ltd for the allowable load.

Load factors must cumulate, for example:

A wheel with a 'maximum load rating' of 1000kg is to be subjected to continuous running at 8kph in a driving application,

$$\text{allowable load} = 1000\text{kg} \times 0.75 \text{ (continuous running factor)} \times 0.8 \text{ (speed factor)} \times 0.7 \text{ (driving factor)}$$

$$= 420\text{kg.}$$

5.2 RESISTANCE TO CHEMICALS

A = little or no effect
B = moderate effect
C = severe effect

Acetic Acid 20% max	B	Formic acid	C	Palmitic acid	A
Acetone	C	Fuel oil	B	Perchloroethylene	C
Ammonia hydroxide	A	Gasoline	B	Phenol	C
Barium hydroxide	A	Glue	A	Phosphoric acid 70%	A
Benzene	C	Hydraulic oils	B	Phosphoric acid 80%+	C
Borax	A	Hydrochloric acid - 20% max.	B	Potassium hydroxide	B
Boric Acid	A	Hydrochloric acid - 30%+	C	SAE No. 10 Oil (70°C)	A
Butane	A	Hydrogen	A	Sea water	A
Calcium bisulphite	A	Isopropyl ether	B	Soap solutions	A
Calcium chloride	A	JP- 4	B	Sodium hydroxide - 20% max.	A
Calcium hydroxide	A	JP -5	C	Sodium hydroxide - 45% max.	B
Carbon dioxide	A	JP - 6	C	Sodium hypochlorite	C
Carbon monoxide	A	Kerosene	B	Soybean oil	B
Carbon tetrachloride	C	Ketone	C	Stearic acid	C
Castor oil	A	Linseed oil	B	Sulphuric acid 10% max.	A
Chlorine	C	Magnesium chloride	A	Sulphuric acid 10%+	B
Chromic acid	C	Magnesium hydroxide	A	Sulphuric acid 50%	C
Copper Chloride	A	Mercury	A	Tannic acid	A
Copper Sulphate	A	Methyl alcohol	C	Toluene	C
Cottonseed oil	A	Methyl ethyl	A	Trichloroethylene	C
Cyclohexane	A	Mineral oils	C	Turpentine	C
Ethyl acetate	C	Naphtha	B	Water (45°C)	A
Ethyl alcohol	C	Naphthalene	B	Water (100°C)	C
Ethylene glycol	B	Nitric acid	C	Xylene	C
Formaldehyde	C	Oils - lubricating	B		

6.0 Rail Wheels

6.1 APPROXIMATION OF ALLOWABLE LOAD FOR CATALOGUE ITEMS

The 'maximum Load Rating' given for each rail wheel (types CSF, SSF,CDF,CFT and SFT) is the maximum load the wheel can carry without permanent deformation and to give an acceptable service life when the full tread width is in contact with the rail.

In practice full contact with the rail across the tread width is rarely achieved due to

- Flange to rail clearance.
- Wheel overhang
- Rail corner radii

Allowable load capacities of catalogue items used on a given rail can be determined as follows:-

$$\text{Allowable Load} = \frac{\text{useable Rail width (per 6.2.4)}}{\text{full tread width (per catalogue)}} \times \text{maximum load rating (per catalogue)}$$

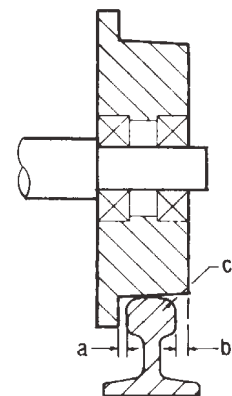

Note:

- The 'useable rail width' (per para 6.2.4) takes into account the profile of the rail head, whether convex or flat.
- The above applies to wheels with very light axial (flange) loads when fitted with bearings. Heavy axial loads will severely limit the radial load carrying capacity of the bearings – see 7.1
- 'Maximum Load Ratings' of catalogue items are based on $P_L = 0.52$, $C_1=1.1$, $C_2 = 0.9$ for steel wheels, and $P_L = 0.15$, $C_2 = 0.8$ for cast iron wheels - refer to 6.2 & 6.3 for relevant equations.

6.2 CALCULATION OF ALLOWABLE LOAD - STEEL OR S.G IRON RAIL WHEELS

The following equations can be used for wheels of up to 1.25m diameter of cast, rolled or forged steel, or S.G cast iron, to determine the relationship between:

- i) wheel diameter
- ii) ultimate strength of wheel material
- iii) load capacity
- iv) service life
- v) the useable width of the rail
- vi) speed of rotation of the wheel.

a) for the wheel to withstand the maximum static load to which it is subjected:

$$P_L \geq \frac{P_S \text{ mean}}{b \times D \times C_{1 \text{ max.}} \times C_{2 \text{ max.}}} = \frac{P_S \text{ mean}}{b \times D \times 1.38}$$

and

b) For the wheel to perform its specified duty without abnormal wear:

$$P_L \geq \frac{P_d \text{ mean}}{b \times D \times C_1 \times C_2}$$

- Where:
- D = wheel diameter (mm)
 - b = useable rail width (mm) – see 6.2.4
 - P_L = limiting pressure (kgf/mm²) – see 6.2.1
 - C_1 = a coefficient determined by r.p.m. – see 6.2.2
 - $C_{1 \text{ max.}}$ = 1.2
 - C_2 = a coefficient determined by ‘machine life and utilisation’ – see 6.2.3
 - $C_{2 \text{ max.}}$ = 1.15
 - $P_{S \text{ mean}}$ = the mean static load to be withstood by the wheel (kg)
 - = $\frac{2P_{S \text{ max.}} + P_{S \text{ min.}}}{3}$
 - $P_{d \text{ mean}}$ = the mean dynamic load to be withstood by the wheel (kg)
 - = $\frac{2P_{d \text{ max.}} + P_{d \text{ min.}}}{3}$

6.2.1 Determining the limited pressure P_L (as a function of the ultimate strength of the metal of which the rail wheel is made)

Notes:

- i) in the case of wheels heat treated to increase the surface hardness, the value of P_L is limited to that of the steel prior to surface treatment.
- ii) The ‘Limiting Pressure’ P_L is a notional pressure determined by supposing that the contact between wheel and rail takes place over a surface whose length is a diameter of the wheel, and width is the ‘useable rail width’ b.

P_L Kgf/mm ²	ULTIMATE STRENGTH OF METAL USED FOR RAIL WHEEL N/MM ² (SEE NOTE I)
0.50	500
0.56	600
0.65	700
0.72	800

6.2.2 Determining coefficient C_1

WHEEL ROTATIONAL SPEED, R.P.M.	C_1	WHEEL ROTATIONAL SPEED, R.P.M.	C_1	WHEEL ROTATIONAL SPEED, R.P.M.	C_1
5.0	1.17	20.0	1.06	63	0.91
5.6	1.16	22.4	1.04	71	0.89
6.3	1.15	25.0	1.03	80	0.87
8.0	1.14	28.0	1.02	90	0.84
10.0	1.13	31.5	1.00	100	0.82
11.2	1.12	35.5	0.99	112	0.79
12.5	1.11	40.0	0.97	125	0.77
14.0	1.10	45.0	0.96	160	0.72
16.0	1.09	50.0	0.94	200	0.66
18.0	1.07	56.0	0.92		

Design Data

BRAUER®

6.2.3 Determining coefficient C₂ (machine life and utilisation)

Should a longer service life be required for a given material whose load/life properties have been determined per paragraph 6.2 refer to paragraph 6.4 'Surface Hardening'.

UTILISATION	SERVICE LIFE – HOURS							
	400	800	1600	3200	6300	12000	25000	50000
Mechanisms subjected very rarely to their maximum load and, normally, to very light loads	1.12	1.12	1.12	1.12	1.12	1.00	0.90	0.80
Mechanisms occasionally subjected to their maximum load, but, normally, to rather lighter loads	1.12	1.12	1.12	1.12	1.00	0.90	0.80	0.80
Mechanisms frequently subjected to their maximum load and, normally, to loads of medium magnitude	1.12	1.12	1.12	1.00	0.90	0.80	0.80	0.80
Mechanisms frequently or constantly subjected to their maximum load	1.12	1.12	1.00	0.90	0.80	0.80	0.80	0.80

6.2.4 Determining the useable rail width, b

The useable rail width is determined by the following equations:

- i) for convex topped rails $b \text{ (mm)} = C - \frac{4}{3} r$ (these are generally flat bottom rails) ii) for flat topped rails $b \text{ (mm)} = C - 2r$ (these are generally bridge, crane and barstock rails)

Dimensions and Useable Widths of a selection of rails are given below. These are for illustration only and details may deviate. Brauer recommend consulting the rail supplier for detailed cross section of rail selected before finalising the design of the wheel tread.

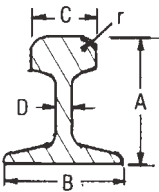
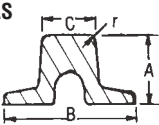
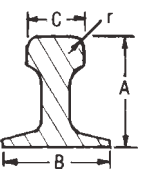
RAIL TYPE	RAIL SECTION IDENTITY	SECTION WEIGHT		PRINCIPAL DIMENSIONS (mm)					USABLE WIDTH b (mm)		
		kg/m	lb/yd	HEIGHT A	BASE B	HEAD WIDTH C	WEB D	RADIUS r			
FLAT BOTTOM RAILS 	British	X BS 20 'M'	9.881	20	65.09	55.56	30.96	6.76	6.35	22.49	
		X BS 30 'M'	14.785	30	75.41	69.85	38.10	9.13	7.92	27.54	
		BS 35 'M'	17.387	35	80.96	76.20	42.86	9.13	7.92	32.30	
		BS 35 'R'	17.360	35	85.73	82.55	44.45	8.33	7.92	33.89	
		X BSC 40	19.890	40	88.11	80.57	45.64	12.30	9.13	33.47	
		ACSE 40	20.09	40.5	88.9	88.9	42.60	9.9	7.94	32.02	
		X BS 50 'O'	24.833	50	100.01	100.01	52.39	10.32	8.73	40.75	
		BS 60 'R'	29.822	60	114.30	109.54	57.15	11.11	9.53	44.44	
		X BS 60 'A'	30.618	60	114.30	109.54	57.15	11.11	9.53	44.44	
		BS 70 'A'	34.807	70	123.82	111.12	60.32	12.30	9.53	47.61	
		BS 75 'R'	37.041	75	128.59	122.24	61.91	13.10	11.11	47.10	
		BS 75 'A'	37.455	75	128.59	114.30	61.91	12.70	11.11	47.10	
		BS 80 'O'	39.781	80	127.00	127.00	63.50	13.89	9.53	50.79	
		BS 80 'R'	39.674	80	133.35	127.00	63.50	13.49	11.11	48.69	
	BS 80 'A'	39.761	80	133.35	117.47	63.50	13.10	11.11	48.69		
	BS 90 'R'	44.506	90	142.88	136.53	66.67	13.89	12.70	49.74		
	BS 90 'A'	45.099	90	142.88	127.00	66.67	13.89	12.70	49.74		
	BS 95 'A'	47.142	95	147.64	141.29	68.26	14.29	12.70	51.33		
	BS 95 'N'	46.951	95	147.64	139.70	69.85	13.89	12.70	52.92		
	BS 113 'A'	56.398	113	158.75	139.70	69.85	20.00	12.70	52.92		
BRIDGE RAILS 	British	X BSC 13	13.306	26.77	48.0	92.0	36.00	–	11.00	14.00	
		X BSC 16	16.029	32.25	54.0	108.0	44.50	–	10.50	23.50	
		X BSC 20	19.861	39.95	55.5	127.0	50.00	–	9.53	30.94	
		X BSC 28	28.624	57.58	67.0	152.0	50.00	–	9.00	32.00	
		X BSC 35	35.375	71.16	76.0	160.0	58.00	–	10.00	38.00	
		X BSC 50	50.179	100.00	76.0	165.0	58.50	–	10.00	38.50	
	CRANE RAILS 	British	X BSC 56	58.806	114.27	101.5	171.0	–	9.53	56.94	
			X BSC 89	89.81	180.67	114.0	178.0	102.00	–	10.00	82.00
			X BSC 101	100.383	201.94	155.0	165.0	100.00	–	10.00	80.00
			X BSC 164	166.83	335.61	150.0	230.0	140.00	–	10.00	120.00
European	A45	22.1	–	55	125	45.00	24	4.00	37.00		
	A55	31.8	–	65	150	55.00	31	5.00	45.00		
	A65	43.1	–	75	175	65	38	6	53.00		
	A75	56.2	–	85	200	75	45	8	59.00		
	A100	74.3	–	95	200	100	60	10	80.00		
	A120	100	–	105	220	120	72	10	100.00		
	A150	150.3	–	150	220	150	80	–	–		

ITEMS SHOWN IN BOLD ARE NORMALLY AVAILABLE FOR NEW BUILD

NOTE: Items with X are not manufactured by steel mills now.
Items in bold are at time of printing still currently manufactured.

DESIGN DATA

6.3 CALCULATION OF ALLOWABLE LOAD - CAST IRON RAIL WHEELS

While grey cast iron wheels are the most economic for light to medium duty, they are not suitable for high rotational speeds or where substantial shock loadings are to be withstood. Their performance is not as predictable as that of steel or S.G. iron wheels due principally to the presence of flake graphite which encourages 'spalling' of the surface.

6.3.1 Allowable Load - grey iron as cast

The relationship between:

- i) Wheel diameter
- ii) Load capacity
- iii) Useable rail width

Where:- D = wheel diameter (mm)
 b = useable rail width (mm) – see 6.2.4
 P_L = 0.15 (a conservative value to provide an acceptable service life)
 $C_{2\max}$ = 0.8

but **not** service life, can be approximated by the equation $P_L = \frac{P_{\max}}{b \times D \times C_{2\max}}$ P_{\max} = maximum load to be withstood by the wheel (kg)

6.3.2 Allowable Load - chilled cast iron or surface hardened cast iron

Chilling or surface hardening of cast iron refines and hardens the surface to give an economic wheel capable of carrying moderate loads, with a service life similar to that of comparable steel wheels. For cast iron wheels having a hardened surface, the equation for steels wheels applies (para 6.2) with a value $P_L = 0.50$

6.4 SURFACE HARDENING

Surface hardening can extend service life beyond that given in para 6.2.3. a guide to the relationship between surface hardness and service life being:

Note: The surface hardness of the wheel must be taken into account when selecting the rail.

SURFACE HARDNESS (Hv)	LIFE FACTOR (240 HV = 1)
240	1.0
280	1.7
320	2.0
360	2.2
400	2.3

6.5. FLANGE STRENGTH

An approximation of rail wheel flange strength sufficient for most purposes can be determined as follows:

$$\text{Allowable flange bending moment } M \text{ (Nmm)} = \frac{\sigma_{tu} \times 1.5 \times t_f^3}{6 \times N \times K_m \times K_c}$$

$$\text{Allowable flange load due to bending } P \text{ (kg)} = \frac{M}{9.81 \times e}$$

Note: Moments about bearings and axial loads on bearings due to flange loads must be taken into account when selecting bearings and axle/bearing arrangements -see 7.1

Where:

σ_{tu} = tensile strength of the wheel material (N/mm²)
 t_f = Flange thickness (mm)
 N = Flange safety factor (2.0 minimum recommended)
 K_m = load factor = 1.0 for gradually applied loads
 = 1.5 for suddenly applied loads
 K_c = casting factor (for cast wheels only) = 1.5
 e = dimension (mm) from tread to point of application of load P as shown;

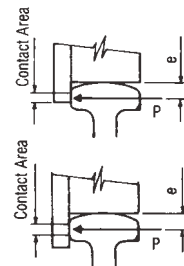

7.0 Bearing and Seal Arrangements – Non Standard Wheels

7.1 SELECTION OF BEARINGS

The main considerations in the selection of bearings are:

- i) radial load
- ii) axial load
- iii) speed of rotation
- iv) bearing friction

In selecting ball or roller bearings it is important that the static and/or dynamic radial load rating requirement for each bearing should be determined taking into account a) the radial load. b) the radial equivalent or any axial load (as given in the bearing manufacturer's catalogue), and c) the radial load resulting from the moment of the axial load acting about the bearings.

It should be noted that in most bearing arrangements axial loads are taken by only one bearing, and that loads caused by condition c) above usually act positively on one bearing (being added to the radial load) and negatively on the other bearing (being deducted from the radial load).

DESCRIPTION	GENERAL ARRANGEMENT	RADIAL LOAD	AXIAL LOAD	SPEED OF ROTATION	BEARING FRICTION
1. Plain bronze or self-lubricating bushing		Very High	Very Light	Low	Moderate/High
2. Flanged bronze or self-lubricating bushing		Very High	High	Low	Moderate/High
3. Ball bearings		Light/Moderate	Light	High	Low
4. Opposed taper roller bearings		Moderate	Moderate	High	Low
5. Spherical roller bearings		High	Light/Moderate	High	Low
6. Spherical roller or cylindrical roller bearings and thrust washers or thrust bearings		High	Very High	High	Low
7. Needle roller bearings and thrust washers or thrust bearings		Very High	Very High	High	Low

7.2 BEARING SEALS

Bearing seals perform two main functions:

- i) To prevent the ingress of material which will affect the life of performance of the bearing,

and/or

- ii) To retain lubricant, particularly in hot or hostile environment.

Some typical sealing arrangements are illustrated:

DESCRIPTION	GENERAL ARRANGEMENT	APPLICATION NOTES
1. Bearings with seals and/or metal shields		Seals can be on one (outer) side only for lubrication via a grease nipple, or sealed both sides in 'sealed for life' applications. Seals of this type are not generally available for roller bearings.
2. Metal external shields		The simplest way of shielding roller or taper roller bearings, but without providing a complete seal.
3. Spring loaded lip seals		Provides excellent sealing. Spring should face outwards for grease renewal via a nipple and to prevent ingress of material, and inwards to retain lubricant in 'sealed for life' applications. Normal temperature range -40°C to +100°C.
4. Felt seals		Useful in high temperature applications in conjunction with suitable lubricants. Provide effective sealing of split housings.
5. 'O' ring seals		Can provide complete sealing, particularly against external pressure such as in underwater applications. Suitable only for circumferential surface speeds of less than 30m/min and temperatures of -40°C to +110°C.
6. Pressed steel labyrinth		Suitable only for 'sealed for life' applications as regreasing via a nipple tends to force the labyrinth out of its housing. Extra sealing can be obtained by inserting greased felt washers within the labyrinth during assembly.
7. Machined labyrinth		Can be used in conjunction with spring-loaded lip seals to provide the most effective seal in hostile environments.

8.0 Inertial and Rolling Resistance

The main forces resisting initial movement and acceleration of a wheeled vehicle are :

- i) the rolling friction between the wheel and the surface on which it rests and in the case of tyred wheels, the rolling resistance of the flat area of tread caused by static loading.
- ii) the friction within the wheel or axle bearings.
- iii) the inertial resistance of vehicle and load.

The main forces resisting the maintenance of movement after acceleration from rest are i) and ii) above (excluding the effect of a tyre 'flat')

8.1 ROLLING FRICTION

8.1.1 Polyurethane tyred wheels

Guide figures for rolling resistance per wheel as a percentage of load per wheel.

- i) from rest , when the period of rest is 8 hours maximum = 5% of load.
- ii) from rest, when the period of rest is greater than 8 hours = 8% of load.
- iii) to maintain a constant speed = 3% of load.

Note: these figures are approximations as they are influenced by such factors as ambient temperatures, the track surface, the load/rest cycle timing, wheel diameter etc.

8.1.2 Rail wheels

When a body rolls on a surface, the force resisting the motion is termed rolling friction.

The force required to overcome rolling friction of a rail wheel in constant motion is determined by the equation: $F = \lambda \times P$

Where: F = Force required to overcome rolling friction(kgf) per wheel.
 λ = Lambda, the coefficient of rolling friction.
 P = Load per wheel (kg).

8.1.2.1 Determining the coefficient of rolling friction λ

Contact Pressure (Hertz) Between Wheel and Rail (Kgf/mm ²)	Coefficient of Rolling Friction λ
30	0.005
40	0.007
50	0.008
60	0.010
70	0.012
80	0.013

The contact pressure (Hertz) between wheel and rail being determined by the equation

$$P_a = \frac{2 \times P}{\pi \times a \times b}$$

Where: P_a = Contact pressure (Hertz) in Kgf/mm²
 P = Load on wheel (kg)
 b = Useable rail width (mm) – see 6.2.4
 a = half the width of the 'plane contact zone' between wheel and rail

$$a = \sqrt{\frac{4 \times P \times R}{\pi \times E' \times b}}$$

Where: P = Load on wheel (kg)
 R = Radius of wheel (mm)
 b = Useable rail width (mm)
 E' = Effective Youngs Modulus of elasticity
 = 7470 Kg/mm² for an iron wheel on a steel rail
 = 11200 Kg/mm² for a steel wheel on a steel rail

8.2 BEARING FRICTION

For the purpose of determining the force required to start or maintain a wheel in motion the frictional resistance of ball or roller bearings, with their coefficient in the region of 0.002, can be disregarded.

The force required to overcome bearing friction for plain bearings is determined by the equation: $F = \frac{\mu \times P \times d}{D}$

Where: F = force required to overcome bearing friction(kg)
 μ = The coefficient of friction
 P = load on wheel (kg)
 d = diameter of axle (mm)
 D = diameter of wheel (mm)

The table gives guide figures for the coefficient of friction μ for rolling bearings and for various plain bearing materials running on a smooth steel axle.

The lubricated coefficient should be used for wheels in motion, and the unlubricated coefficient for wheels starting from a period of rest under static load (which assumes the worst condition)

Bearing Material	Coefficient of Friction μ	
	Lubricated	Unlubricated
Cast iron	0.21	0.40
Bronze	0.16	0.35
Thin wall PTFE/Lead wrapped bushes	0.02 - 0.20	0.02 - 0.20

8.3 INERTIAL RESISTANCE

To calculate the force required to accelerate the mass of the vehicle and its load from rest with a uniform rate of acceleration on a level track:

i) when the time taken to achieve the final velocity is known $F = \frac{M \times V_f}{t \times g}$

or, ii) when the distance taken to achieve the final velocity is known $F = \frac{M \times V_f^2}{2 \times s \times g}$

Where: F = force required to overcome inertia (kg)
 M = total mass of vehicle and load (kg)
 V_f = final velocity (m/sec)
 t = time taken to achieve final velocity from rest (secs)
 s = distance taken to achieve final velocity from rest (m)
 g = force of gravity = 9.81 m/sec²

9.0 Traction – Coefficient of Friction

The traction of a driving wheel = $\mu \times P$

Where: μ = the coefficient of friction for a given wheel material and track surface.
 p = the load of the wheel.

Guides values for coefficients of friction μ , for wheel and tyre materials in contact with various surfaces are given:

Surface	Wheel or Tyre Material				
	Rubber	Polyurethane	Steel	Cast Iron	Nylon
Dry Steel	0.8	0.7	0.6	0.4	0.4
Wet Steel	0.5	0.4	0.4	0.3	0.15
Dry Smooth Concrete	0.8	0.7	–	–	–
Wet Smooth Concrete	0.5	0.6	–	–	–
Dry Rough Concrete	1.0	0.8	–	–	–
Wet Rough Concrete	0.9	0.6	–	–	–
Ice	0.1	0.1	0.02	0.02	–

10.0 Load Calculations For Wheels Supporting and/or Driving Rotating Drums.

In installations where support wheels drive the drum we recommend that the driving wheels be positioned on the upwardly rotating side of the drum (as shown below) which is the more heavily laden side.

To determine the required 'Maximum Load Rating' for wheels at each support position for the purpose of wheel selection:

$$\text{Maximum Load Rating – Drive Wheel} = \frac{(0.5P_1) + P_2}{\text{Cos } \alpha \times L \times L_S \times L_C}$$

$$\text{Maximum Load Rating – Idler Wheel 1} = \frac{0.5(P_1 + P_2)}{\text{Cos } \alpha \times L_S \times L_C}$$

$$\text{Maximum Load Rating – Idler Wheel 2} = \frac{(0.5P_1) + P_2}{\text{Cos } \alpha \times L_S \times L_C}$$

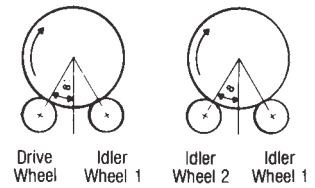
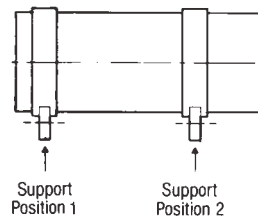

Where: P_1 = weight of the drum at the support position under consideration (kg)
 P_2 = weight of the contents at the support position under consideration (kg)
 L = 0.7 = Load factor for driving wheels (polyurethane tyred wheels only)
 L_S = Load factor according to drum surface speed – see 5.1 (polyurethane tyred wheels only)
 L_C = 0.75 = Load factor for continuous running - see 5.1 (polyurethane tyred wheels only)

11.0 Keyway Dimensions – Parallel Key

Generally - (to commercial tolerances – keyways to BS46: part 1: 1958 and BS4235: part 1: 1972 available to order)

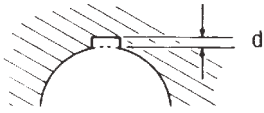

METRIC			
BORE Ø -0.00 +0.05	KEY SECTION		Keyway depth 'd' -0.0 +0.2
	WIDTH	HEIGHT	
12	4	4	1.8
20	6	6	2.8
25	8	7	3.3
30	8	7	3.3
35	10	8	3.3
40	12	8	3.3
50	14	9	3.8
60	18	11	4.4
75	20	12	4.9
100	28	16	6.4
150	36	20	8.4

INCH			
BORE Ø -0.000 +0.002	KEY SECTION		KEYWAY DEPTH 'd' -0.00 +0.006
	WIDTH	HEIGHT	
0.5	0.125	0.125	0.060
0.75	0.188	0.188	0.088
1.00	0.250	0.250	0.115
1.25	0.312	0.250	0.112
1.50	0.375	0.250	0.108
2.00	0.500	0.312	0.131
2.50	0.625	0.438	0.185
3.00	0.750	0.500	0.209
3.50	0.875	0.625	0.264
4.00	1.00	0.750	0.318

12.0 Reference Tables and Conversion Factors

12.1 HARDNESS CONVERSIONS AND EQUIVALENT TENSILE STRENGTH

VICKERS HARDNESS NUMBER HV	BRINELL HARDNESS NUMBER BHN	ROCKWELL C HRC	EQUIVALENT ULTIMATE TENSILE STRENGTH	
			N/mm ²	tons/in ²
500		49.7	1599	103
490		49.0	1568	101
480		48.2	1536	99
470	446.5	47.5	1504	97
460	437.0	46.7	1472	95
450	427.5	45.9	1441	93
440	418.0	45.1	1409	91
430	408.5	44.3	1377	89
420	399.0	43.5	1345	87
410	389.5	42.6	1314	85
400	380.0	41.7	1282	83
390	370.5	40.8	1250	81
380	361.0	39.8	1219	79
370	351.5	38.8	1188	77
360	342.0	37.8	1155	75
350	332.5	36.8	1124	73
340	323.0	35.7	1092	71
330	313.5	34.5	1059	69
320	304.0	33.5	1029	67
310	294.5	32.2	997	65
300	285.0	30.9	965	62
290	275.5	29.6	934	60
280	266.0	28.2	902	58
270	256.5	26.7	870	56
260	247.0	25.1	838	54
250	237.5	23.5	807	52
240	228.0	21.8	774	50
230	218.5	20.0	743	48
220	209.0		712	46
210	199.5		680	44
200	190.0		648	42
190	180.5		617	40
180	171.0		584	38
170	161.5		553	36
160	152.0		522	34
150	142.5		490	32
140	133.0		458	30
130	123.5		427	28

12.2 TENSILE STRENGTHS OF HEAT TREATED STEELS

HEAT TREATMENT CONDITION	TENSILE STRENGTH RANGE	
	N/mm ²	Tons/in ²
P	550 – 700	35 – 45
Q	625 – 775	40 – 50
R	700 – 850	45 – 55
S	775 – 925	50 – 60
T	850 – 1000	55 – 65
U	925 – 1075	60 – 70
V	1000 – 1150	65 – 75
W	1075 – 1225	70 – 80

12.3 USEFUL CONVERSION FACTORS

TO CONVERT	TO	MULTIPLY BY
Length: inch	(in) metre (m)	0.0254
foot	(ft) metre (m)	0.3048
Area: square inch	(in ²) square millimetre (mm ²)	645.16
Volume: cubic inch	(in ³) cubic metre (m ³)	16.39 x 10 ⁻⁶
cubic foot	(ft ³) cubic metre (m ³)	0.02832
Mass: kilogramme	(kg) newton (N)	9.807
pound	(lb) newton (N)	4.448
pound	(lb) kilogramme (kg)	0.4536
Torque: pound force inch	(lbf.in) kilogramme force metre (kgf.m)	0.0115
pound force inch	(lbf.in) newton millimetre (Nmm)	113.0
Pressure/ Stress: pound per square inch	(lb/in ²) newton per square millimetre (N/mm ²)	0.006895
ton per square inch	(ton/in ²) newton per square millimetre (N/mm ²)	15.445

13.0 Castors

13.1 EXAMPLES OF POSSIBLE CASTOR ARRANGEMENTS

2 Swivel Castors and 2 Fixed Castors

Providing good load capacity and manoeuvrability, this arrangement ensures accurate steering, even on long straight runs, making it the most practical arrangement for industrial use. Any trolley with this castor arrangement should be pushed with the fixed castors leading.

$$\text{Maximum loading for each castor} = \frac{\text{Gross load}}{3}$$

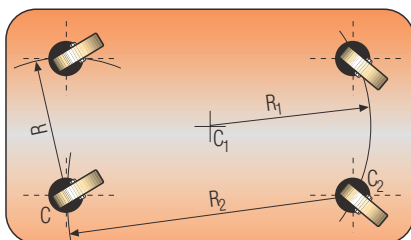
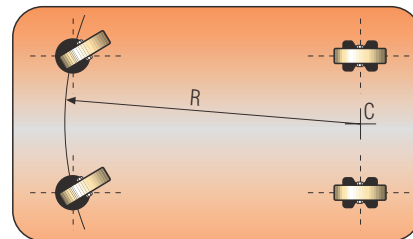

4 Swivel Castors

As this arrangement gives good load capacity with exceptional manoeuvrability, it is suitable for winding runs and where sideways action is required. It is not recommended for straight runs or ramps, as it may be hard to guide, especially over bumpy terrain and when heavily loaded. **However, equipping two castors with directional locks makes this arrangement very versatile and suitable for long straight runs.**

$$\text{Maximum loading for each castor} = \frac{\text{Gross load}}{3}$$

1 Swivel Castor and 2 Fixed Castors

This arrangement provides an economical solution for lightly loaded trolleys requiring good manoeuvrability. The trolley must be reasonably small in size and any load must be evenly distributed to ensure stability.

$$\text{Maximum loading for each castor} = \frac{\text{Gross load}}{2.5}$$

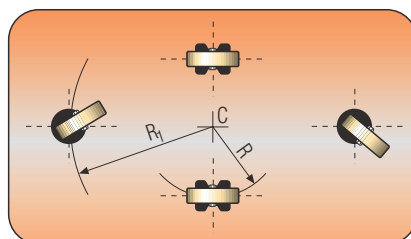
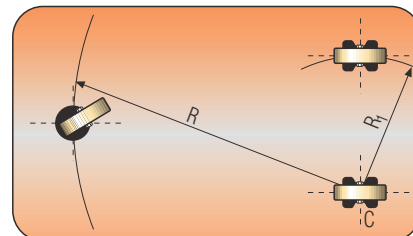

2 Swivel Castors and 2 Fixed Castors centrally pivoting

Ideal for confined spaces, this arrangement provides good load capacity with excellent manoeuvrability. The fixed castors can be replaced by an 'A' series axle assembly (see page 87) and wheels which pivot the trolley centrally. In this case, 25mm of packing is necessary above the two fixed castors (wheels) to give alternating load support. However if the trolley is tipped or the load is not evenly distributed, the swivel castors are subjected to shock loads.

The entire load rests on the two central, fixed castors/wheels.

$$\text{Maximum loading for each wheel/castor} = \frac{\text{Gross load}}{2}$$

4 Swivel Castors and 2 Fixed Castors centrally pivoting

This arrangement provides an extremely high load capacity, with great manoeuvrability and stability. This is ideal for very long trolleys designed to carry heavy loads – the fixed castors can be replaced by wheels mounted onto a central 'A' series axle (see page 87). The unit's base must be robust and the swivel castors are mounted to allow the trolley to pivot on the central wheels. Therefore, 25mm of packaging is required above the two fixed castors (wheels) to give alternating load support, depending on which pair of wheels is in contact with the floor. The entire load rests on 2 central, fixed castors/wheels.

Please note that the swivel castors are subjected to shock loads if the trolley is tipped or the load is not evenly distributed.

$$\text{Maximum loading for each wheel/castor} = \frac{\text{Gross load}}{2}$$

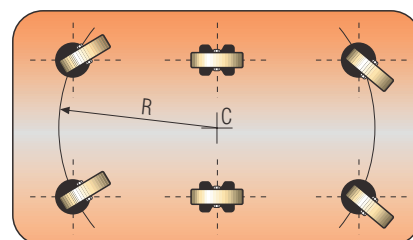

3 Swivel Castors

This provides good load capacity with excellent manoeuvrability. However, equipment with this arrangement will be difficult to guide on straight runs particularly over uneven ground.

This arrangement is ideal for barrel dollies and small portable machines.

$$\text{Maximum loading for each wheel} = \frac{\text{Gross load}}{2.5}$$

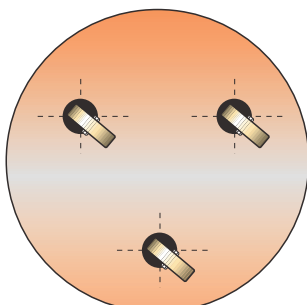

2 Fixed Castors and 2 Fixed Castors centrally pivoting.

Suitable for moderate loads and long, straight runs with occasional changes in direction.

The two central fixed castors can be replaced by wheels mounted onto a central 'A' series axle (see page 87). The two end castors are mounted as to pivot the trolley centrally.

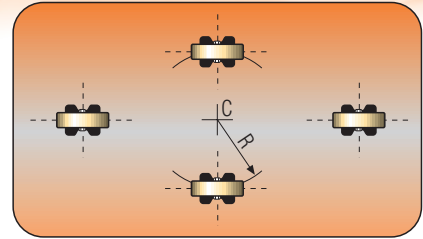
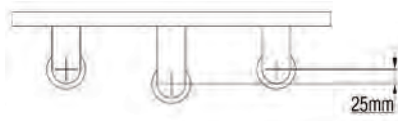

25mm of packing is necessary above the two central castors (wheels) to give alternating load support. However if the trolley is tipped or the load is not evenly distributed, the end castors are subject to shock loads. The entire load rests on the 2 central, fixed castors/wheels.

$$\text{Maximum loading for each wheel/castor} = \frac{\text{Gross load}}{2}$$

13.1.2 Correct alignment of castors

- Fixed and directional lock swivel castors - the mounting holes in the top plates are clearance holes and it is essential to align the castors correctly before the bolts are finally tightened.
- Swivel castors - it is essential they are mounted with the swivel axis vertical

13.1.3 Important Note The formulae above for the maximum loading for each castor is for an equally distributed load.

13.2 LOAD RATING

13.2.1 Limitations to stated maximum load rating for each model number:-

- Untyred wheels - refer to design data para 2.0
- rubber tyred wheels - refer to design data para 3.0
- Polyurethane tyred wheels - refer to design data para 5.0

13.2.2 Floor conditions

The stated maximum load rating for each model assumes that the floor is reasonably level and free from cracks, obstructions, guide rails, gullies etc.

If any of the above are present in the operating environment then a castor with a load rating several times greater than calculated must be used. In addition the wheel diameter must be large enough to easily pass over any cracks, ridges and other obstructions.

13.3 MANUAL PROPULSION

The generally accepted effort an average human is capable of exerting is:-

- 18 Kgf for moving from a standing start
- 12 Kgf for a short distance once in motion
- 6 Kgf for longer distances on travel

For inertial and rolling resistance, refer to design data para 8.0 and for traction design data para 9.0

13.4 POWER TOWING

Obstructions such as kerbs and gullies and even relatively small steps, can exert enormous impact loads which can damage a castor. Steps such as lift sills, drains covers and joints in concrete slabs, present a particular problem if they are not approached squarely and at low speeds. Approaching such obstacles obliquely makes the castor turn at right angles to the obstruction instead of turning in such a way that it can climb over it, this damages the castor.

Towing trailers in train increases the problem as only one castor may have to withstand the force generated by the mass of the whole train including the tractor.

When towing trailers in train the diagram below illustrates the position of the pin couplings relative to the rear fixed castors to ensure the weight of the trailer and its contents are evenly distributed between the front swivel castors and rear fixed castors as well as ensuring good tracking.

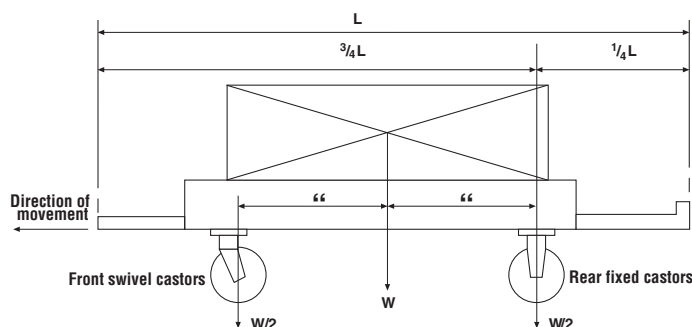

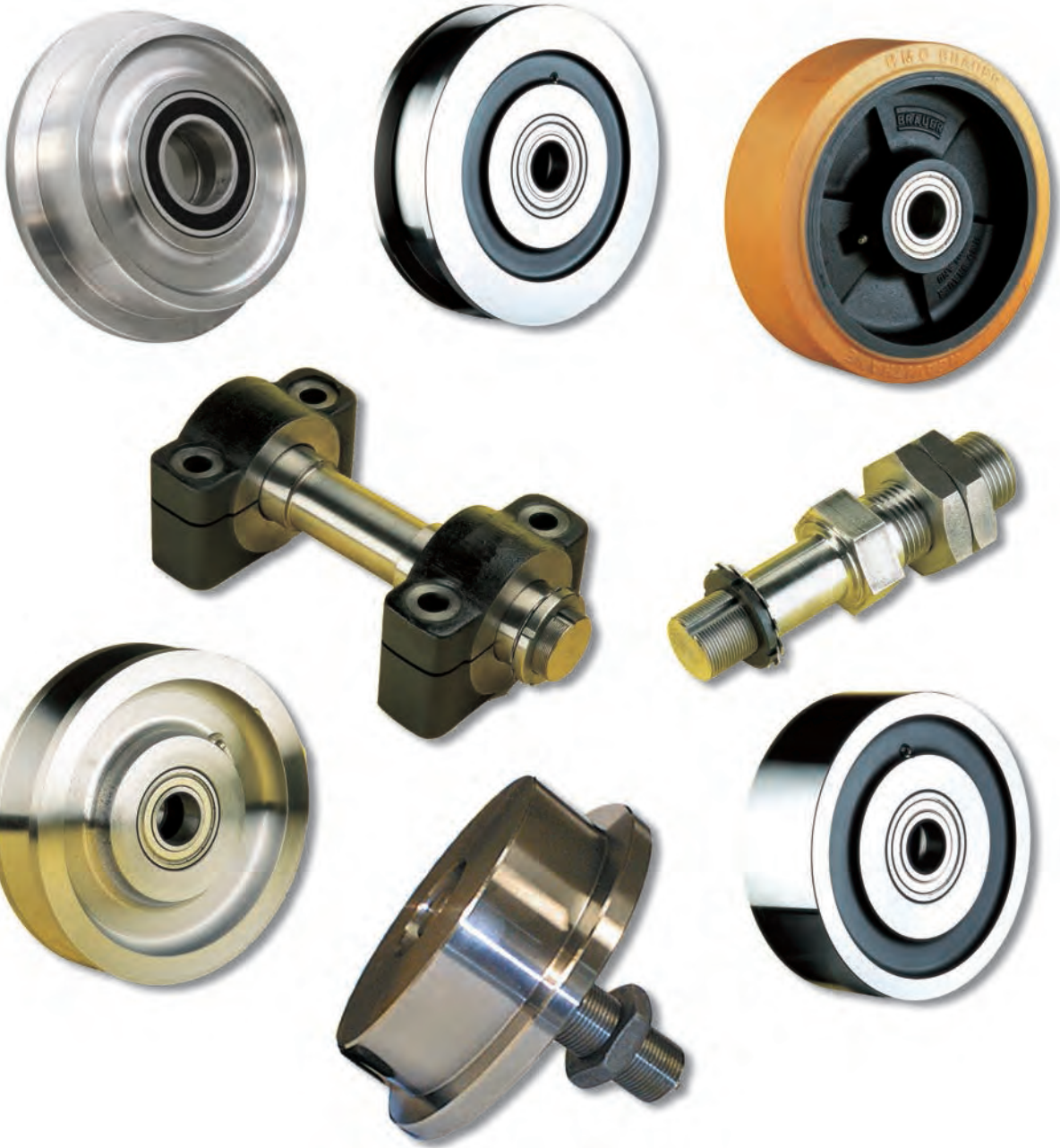

WHEELS AND AXLE ASSEMBLIES

Part Numbering Brauer wheels have descriptive part numbers as shown by the following example:

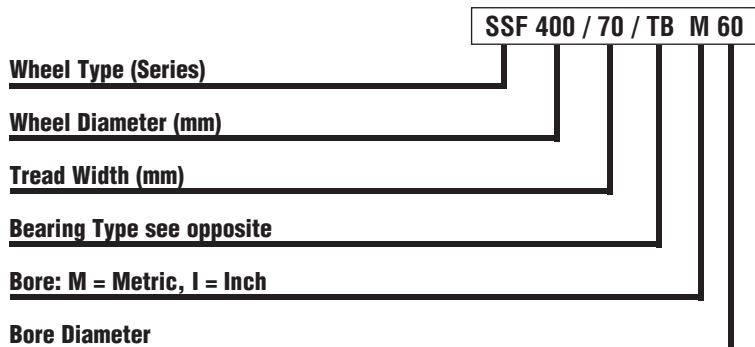

BEARING TYPES	
BJ	= Ball Journal
TB	= Taper Roller
CRB	= Cylindrical Roller
SPHBR	= Spherical Roller
PB	= Plain bore
K	= Keyway
SL	= Self lubricating bush

Non-catalogue items use the same descriptive part numbering system prefixed by the word specified, abbreviated as "spec".

Steel Single Flanged Rail Wheels



MATERIAL: Steel to BS970: Part 1: 1983: 080M40

OPERATING TEMPERATURE RANGE:

Plain bored or keywayed wheels – 30°C to 350°C

Ball or taper roller bearinged wheels – 40°C to 120°C

The 'maximum load rating' given for each wheel is based on the full tread width being in contact with the rail. Working loads must be calculated based on the useable rail width and operating conditions – see 'Design Data' paras. 6.1. and 6.2.

Standard wheel features a 3° tread angle to assist centering of pairs of wheels on common axles when used with convex crown rails. When single flanged wheels are to be used singly or on flat topped rails, 'flat treads', (which have the tread parallel to the wheel axis and flanges at a 5° angle) should be specified by adding suffix 'FT' to the part number. (Tread diameter may be reduced)

Alternative bore/bearing diameters and alternative bearing types (i.e. bronze bushes, self-lubricating bushes, roller bearings, spherical roller bearings, etc.) are available to order – see pages 26-27.

Plain bore wheels are not drilled and tapped for greasing unless requested at time of order.

For technical information covering load factors, inertial and rolling resistance, coefficients of friction between wheel and track, and keyway dimensions, see "Design Data" Index on page 20.

**WHEEL TYPE:
SSF75/25**

See table for full part number

**Maximum load rating:
975Kg**

See pages 23-26 for load factors

Approximate weight: 1.4Kg

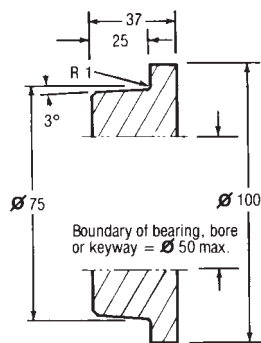

Wheels fitted with ball journals are pre-lubricated, double shielded

**WHEEL TYPE:
SSF100/25**

See table for full part number

**Maximum load rating:
1300Kg**

See pages 23-26 for load factors

Approximate weight: 2.5Kg

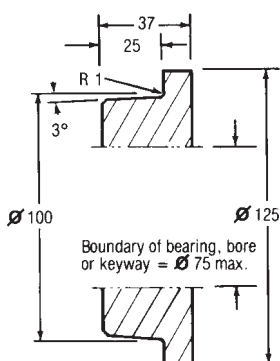

Wheels fitted with ball journals are pre-lubricated, double shielded

FULL PART NUMBER FOR ORDERING

Axle Ø	Plain Bore	Plain Bore Keywayed	Ball Bearing	Taper Roller Bearing
METRIC AXLE Ø				
20		SSF75/25/KM 20	SSF75/25/BJM 20	SSF75/25/TBM 20
25		SSF75/25/KM 25	SSF75/25/BJM 25	SSF75/25/TBM 25

LOAD LIMITED BY BEARINGS TO: (1) 900Kg

- TBM25 is actually Ø52mm recess, but considered acceptable
- Too small for grease nipples

Axle Ø	Plain Bore	Plain Bore Keywayed	Ball Bearing	Taper Roller Bearing
METRIC AXLE Ø				
20		SSF100/25/KM 20	SSF100/25/BJM 20	SSF100/25/TBM 20
25		SSF100/25/KM 25	SSF100/25/BJM 25	SSF100/25/TBM 25

LOAD LIMITED BY BEARINGS TO: (1) 900Kg (2) 1140Kg

- Too small for grease nipples

STEEL SINGLE FLANGED RAIL

Steel Single Flanged Rail Wheels

STEEL SINGLE FLANGED RAIL

WHEEL TYPE:

SSF150/40

See table for full part number

Maximum load rating:

3100Kg

See pages 23-26 for load factors

Approximate weight: **8.5Kg**

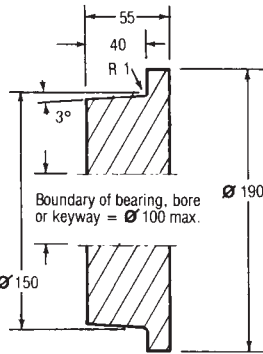

Wheels fitted with ball journals are pre-lubricated, double shielded

WHEEL TYPE:

SSF200/55

See table for full part number

Maximum load rating:

5700Kg

See pages 23-26 for load factors

Approximate weight: **18Kg**

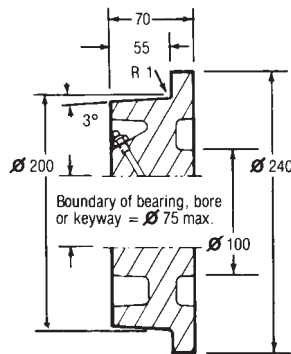

WHEEL TYPE:

SSF250/55

See table for full part number

Maximum load rating:

7100Kg

See pages 23-26 for load factors

Approximate weight: **29Kg**

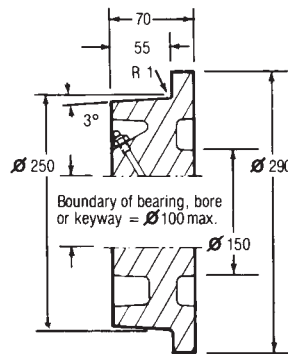

WHEEL TYPE:

SSF300/60

See table for full part number

Maximum load rating:

9300kg

See pages 23-26 for load factors

Approximate weight: **45Kg**

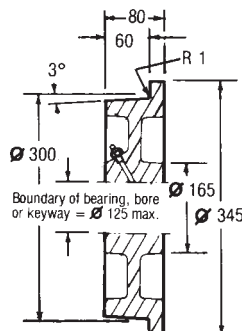

FULL PART NUMBER FOR ORDERING

Axle \varnothing	Plain Bore	Plain Bore Keywayed	Ball Bearing	Taper Roller Bearing
METRIC AXLE \varnothing				
25		SSF150/40/KM 25	SSF150/40/BJM 25 ⁽¹⁾	SSF150/40/TBM 25
30		SSF150/40/KM 30	SSF150/40/BJM 30 ⁽²⁾	SSF150/40/TBM 30
35		SSF150/40/KM 35		

LOAD LIMITED BY BEARINGS TO: (1) 1140Kg (2) 2040Kg

METRIC AXLE \varnothing				
30		SSF200/55/KM 30	SSF200/55/BJM 30 ⁽¹⁾	SSF200/55/TBM 30 ⁽⁴⁾
35		SSF200/55/KM 35	SSF200/55/BJM 35 ⁽²⁾	SSF200/55/TBM 35
40		SSF200/55/KM 40	SSF200/55/BJM 40 ⁽³⁾	SSF200/55/TBM 40

LOAD LIMITED BY BEARINGS TO: (1) 2040Kg (2) 2800Kg (3) 3384Kg (4) 5200Kg

METRIC AXLE \varnothing				
35		SSF250/55/KM 35	SSF250/55/BJM 35 ⁽¹⁾	SSF250/55/TBM 35 ⁽⁴⁾
40		SSF250/55/KM 40	SSF250/55/BJM 40 ⁽²⁾	SSF250/55/TBM 40
50		SSF250/55/KM 50	SSF250/55/BJM 50	SSF250/55/TBM 50

LOAD LIMITED BY BEARINGS TO: (1) 2800Kg (2) 3384Kg (4) 6625Kg

METRIC AXLE \varnothing				
40		SSF300/60/KM 40	SSF300/60/BJM 40 ⁽¹⁾	SSF300/60/TBM 40 ⁽³⁾
50		SSF300/60/KM 50	SSF300/60/BJM 50 ⁽²⁾	SSF300/60/TBM 50

LOAD LIMITED BY BEARINGS TO: (1) 4400Kg (2) 7340Kg (3) 8155Kg

Steel Single Flanged Rail Wheels

BRAUER[®]

FULL PART NUMBER FOR ORDERING

Axle Ø	Plain Bore	Plain Bore Keywayed	Ball Bearing	Taper Roller Bearing
METRIC AXLE Ø				
50		SSF350/60/KM 50	SSF350/60/BJM 50 ⁽¹⁾	SSF350/60/TBM 50 ⁽⁴⁾
60		SSF350/60/KM 60	SSF350/60/BJM 60 ⁽²⁾	SSF350/60/TBM 60
75		SSF350/60/KM 75	SSF350/60/BJM 75 ⁽³⁾	SSF350/60/TBM 75

LOAD LIMITED BY BEARINGS TO: (1) 7340Kg (2) 9785Kg (3) 9000Kg (4) 10600Kg

WHEEL TYPE: **SSF350/60**

See table for full part number

Maximum load rating:

10800Kg

See pages 23-26 for load factors

Approximate weight: **60Kg**

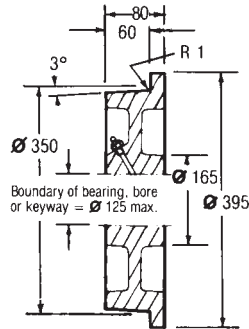

METRIC AXLE Ø

50		SSF400/70/KM 50		SSF400/70/TBM 50 ⁽¹⁾
60		SSF400/70/KM 60	SSF400/70/BJM 60 ⁽³⁾	SSF400/70/TBM 60 ⁽²⁾
75		SSF400/70/KM 75	SSF400/70/BJM 75 ⁽⁴⁾	SSF400/70/TBM 75

LOAD LIMITED BY BEARINGS TO: (1) 10600Kg (2) 13350Kg (3) 9785Kg (4) 9000Kg

WHEEL TYPE: **SSF400/70**

See table for full part number

Maximum load rating:

14400Kg

See pages 23-26 for load factors

Approximate weight: **100Kg**

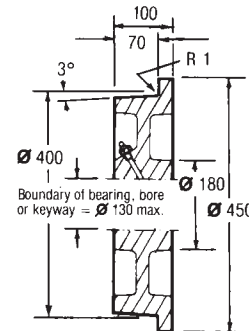

METRIC AXLE Ø

75		SSF450/95/KM 75		SSF450/95/TBM 75 ⁽¹⁾
100		SSF450/95/KM 100		SSF450/95/TBM 100

LOAD LIMITED BY BEARINGS TO: (1) 19400Kg

WHEEL TYPE: **SSF450/95**

See table for full part number

Maximum load rating:

22000Kg

See pages 23-26 for load factors

Approximate weight: **150Kg**

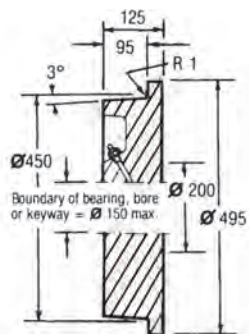

METRIC AXLE Ø

100		SSF600/100/KM 100		SSF600/100/TBM 100
150		SSF600/100/KM 150		SSF600/100/TBM 150

WHEEL TYPE: **SSF600/100**

See table for full part number

Maximum load rating:

30900Kg

See pages 23-26 for load factors

Approximate weight: **280Kg**

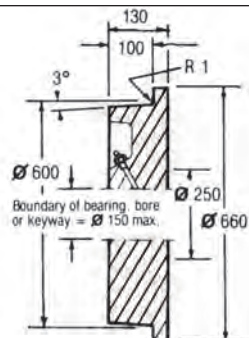

STEEL SINGLE FLANGED RAIL

Cast Iron Single Flanged Rail Wheels



Cast iron rail wheels are the most economic for light to medium duty, but they have a limited service life when compared to steel wheels, and are unsuitable for high rotational speeds or where substantial shock loads are to be withstood.

MATERIAL: Cast iron to BS1452: 1977: Grade 200

The 'maximum load rating' given for each wheel is based on the full tread width being in contact with the rail. Working loads must be calculated based on the useable rail width and operating conditions – see 'Design Data' paras. 5.1. and 5.3.

OPERATING TEMPERATURE RANGE:

- Plain bored or keywayed wheels – 30°C to 250°C
- Ball or taper roller bearing wheels – 30°C to 120°C

Standard wheel features a 3° tread angle to assist centering of pairs of wheels on common axles when used with convex crown rails. When single flanged wheels are to be used singly or on flat topped rails, 'flat treads', (which have the tread parallel to the wheel axis and flanges at a 5° angle) should be specified by adding suffix 'FT' to the part number. (Tread diameter may be required)

Alternative bore/bearing diameters and alternative bearing types (i.e. bronze bushes, self-lubricating bushes, roller bearings, spherical roller bearings, etc.) are available to order – see pages 26-27.

For technical information covering load factors, inertial and rolling resistance, coefficients of friction between wheel and track, and keyway dimensions, see "Design Data" Index on page 20.

CAST IRON SINGLE FLANGED RAIL

WHEEL TYPE:

CSF63/25

See table for full part number

Maximum load rating:

200Kg

See pages 23-26 for load factors

Approximate weight: 1Kg

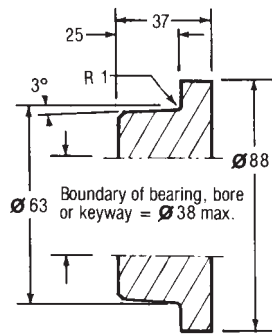

Wheels fitted with ball journals are pre-lubricated, double shielded

WHEEL TYPE:

CSF75/25

See table for full part number

Maximum load rating:

250Kg

See pages 23-26 for load factors

Approximate weight: 1.5Kg

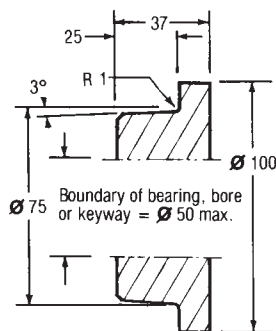

Wheels fitted with ball journals are pre-lubricated, double shielded

FULL PART NUMBER FOR ORDERING

Axle Ø	Plain Bore	Plain Bore Keywayed	Ball Bearing	Taper Roller Bearing
METRIC AXLE Ø				
20	CSF63/25/PBM 20	CSF63/25/KM 20	CSF63/25/BJM 20	
25	CSF63/25/PBM 25	CSF63/25/KM 25		

METRIC AXLE Ø				
20	CSF75/25/PBM 20	CSF75/25/KM 20	CSF75/25/BJM 20	
25	CSF75/25/PBM 25	CSF75/25/KM 25	CSF75/25/BJM 25	
30	CSF75/25/PBM 30	CSF75/25/KM 30		

Cast Iron Single Flanged Rail Wheels



WHEEL TYPE: CSF100/25

See table for full part number

Maximum load rating:

300Kg

See pages 23-26 for load factors

Approximate weight: **2.5Kg**

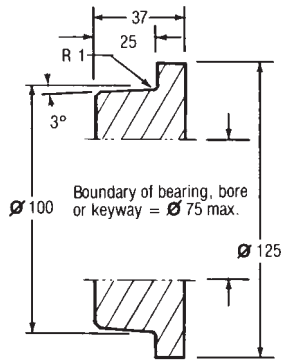

Wheels fitted with ball journals are pre-lubricated, double shielded

WHEEL TYPE: CSF133/35

See table for full part number

Maximum load rating:

600Kg

See pages 23-26 for load factors

Approximate weight: **4.5Kg**

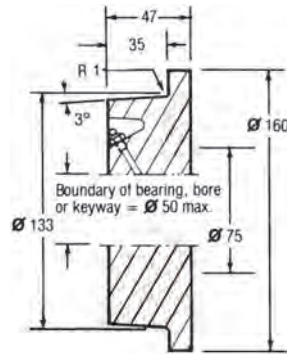

Wheels fitted with ball journals are pre-lubricated, double shielded

WHEEL TYPE: CSF150/40

See table for full part number

Maximum load rating:

800Kg

See pages 23-26 for load factors

Approximate weight: **4.5Kg**

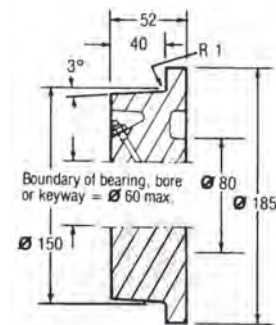

WHEEL TYPE: CSF200/40

See table for full part number

Maximum load rating:

1000Kg

See pages 23-26 for load factors

Approximate weight: **6.5Kg**

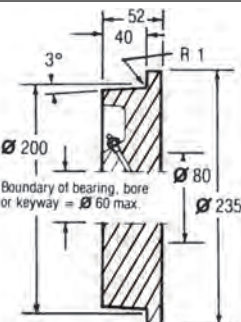

FULL PART NUMBER FOR ORDERING

Axle Ø	Plain Bore	Plain Bore Keywayed	Ball Bearing	Taper Roller Bearing
METRIC AXLE Ø				
20	CSF100/25/PBM 20	CSF100/25/KM 20	CSF100/25/BJM 20	
25	CSF100/25/PBM 25	CSF100/25/KM 25	CSF100/25/BJM 25	
30	CSF100/25/PBM 30	CSF100/25/KM 30		

METRIC AXLE Ø				
20	CSF133/35/PBM 20	CSF133/35/KM 20	CSF133/35/BJM 20	
25	CSF133/35/PBM 25	CSF133/35/KM 25	CSF133/35/BJM 25	
30	CSF133/35/PBM 30	CSF133/35/KM 30	CSF133/35/BJM 30	
35	CSF133/35/PBM 35	CSF133/35/KM 35		

METRIC AXLE Ø				
25	CSF150/40/PBM 25	CSF150/40/KM 25	CSF150/40/BJM 25	
30	CSF150/40/PBM 30	CSF150/40/KM 30	CSF150/40/BJM 30	
35	CSF150/40/PBM 35	CSF150/40/KM 35	CSF150/40/BJM 35	

METRIC AXLE Ø				
25	CSF200/40/PBM 25	CSF200/40/KM 25	CSF200/40/BJM 25	
30	CSF200/40/PBM 30	CSF200/40/KM 30	CSF200/40/BJM 30	
35	CSF200/40/PBM 35	CSF200/40/KM 35	CSF200/40/BJM 35	

CAST IRON SINGLE FLANGED RAIL

Cast Iron Single Flanged Rail Wheels

CAST IRON SINGLE FLANGED RAIL

WHEEL TYPE:

CSF225/55

See table for full part number

Maximum load rating:

1600Kg

See pages 23-26 for load factors

Approximate weight: 15Kg

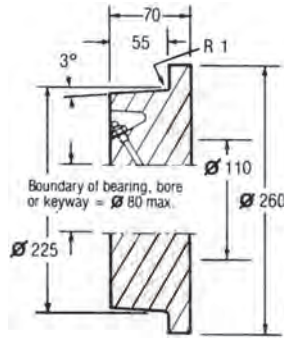

FULL PART NUMBER FOR ORDERING

Axle Ø	Plain Bore	Plain Bore Keywayed	Ball Bearing	Taper Roller Bearing
METRIC AXLE Ø				
30	CSF225/55/PBM 30	CSF225/55/KM 30	CSF225/55/BJM 30	
35	CSF225/55/PBM 35	CSF225/55/KM 35	CSF225/55/BJM 35	
40	CSF225/55/PBM 40	CSF225/55/KM 40		
50	CSF225/55/PBM 50	CSF225/55/KM 50		

WHEEL TYPE:

CSF250/50

See table for full part number

Maximum load rating:

1600Kg

See pages 23-26 for load factors

Approximate weight: 18Kg

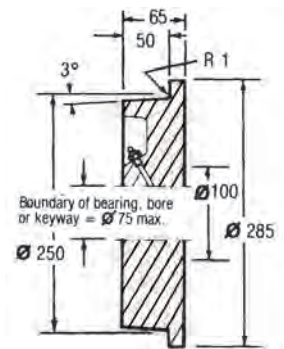

METRIC AXLE Ø				
30	CSF250/50/PBM 30	CSF250/50/KM 30	CSF250/50/BJM 30	
35	CSF250/50/PBM 35	CSF250/50/KM 35	CSF250/50/BJM 35	
40	CSF250/50/PBM 40	CSF250/50/KM 40		
50	CSF250/50/PBM 50	CSF250/50/KM 50		

WHEEL TYPE:

CSF300/60

See table for full part number

Maximum load rating:

2300Kg

See pages 23-26 for load factors

Approximate weight: 28Kg

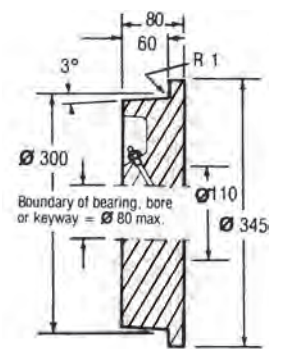

METRIC AXLE Ø				
35	CSF300/60/PBM 35	CSF300/60/KM 35	CSF300/60/BJM 35	
40	CSF300/60/PBM 40	CSF300/60/KM 40	CSF300/60/BJM 40	
50	CSF300/60/PBM 50	CSF300/60/KM 50		

Steel Double Flanged Rail Wheels

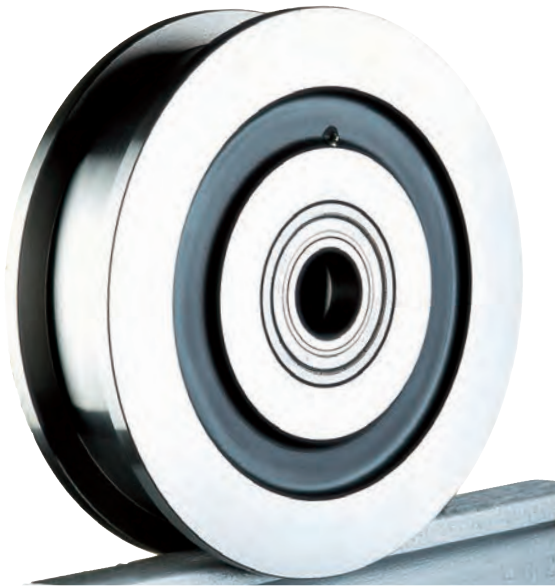

Flanged wheels can be used for guidance paired with an unflanged rail wheel to allow a wide tolerance in the pitch of the rails.

MATERIAL: Steel to BS970; Part I: 1983: 080M40

OPERATING TEMPERATURE RANGE:

- Plain bored or keywayed wheels – 30°C to 350°C
- Ball or taper roller bearinged wheels – 30°C to 120°C

The 'maximum load rating' given for each wheel is based on the full tread width being in contact with the rail. Working loads must be calculated based on the useable rail width and operating conditions – see 'Design Data' paras. 6.1. and 6.2.

Alternative bore/bearing diameters and alternative bearing types (i.e. bronze bushes, self-lubricating bushes, roller bearings, spherical roller bearings, etc.) are available to order – see pages 26-27.

Plain bore wheels are not drilled and taped for greasing unless requested at time of order.

For technical information covering load factors, inertial and rolling resistance, coefficients of friction between wheel and track, and keyway dimensions, see "Design Data" Index on page 20.

FULL PART NUMBER FOR ORDERING

Axle Ø	Plain Bore	Plain Bore Keywayed	Ball Bearing	Taper Roller Bearing
METRIC AXLE Ø				
25		SDF75/35/KM 25	SDF75/35/BJM 25	SDF75/35/TBM 25
30		SDF75/35/KM 30	SDF75/35/BJM 30	SDF75/35/TBM 30

LOAD LIMITED BY BEARINGS TO: (1) 1140Kg

**WHEEL TYPE:
SDF75/35**

See table for full part number

Maximum load rating:

1350Kg

See pages 23-26 for load factors

Approximate weight: **2.5Kg**

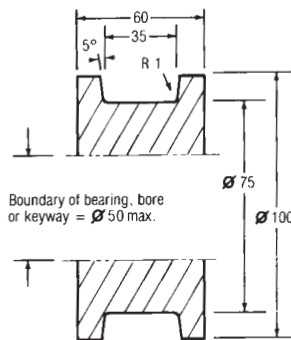

Boundary of bearing, bore or keyway = Ø 50 max.

Wheels fitted with ball journals are pre-lubricated, double shielded

**WHEEL TYPE:
SDF100/35**

See table for full part number

Maximum load rating:

1800Kg

See pages 23-26 for load factors

Approximate weight: **4Kg**

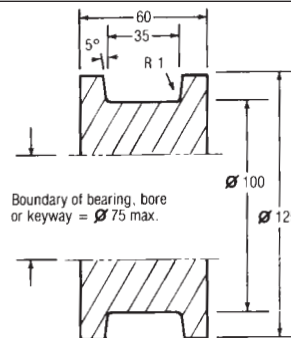

Boundary of bearing, bore or keyway = Ø 75 max.

METRIC AXLE Ø

25		SDF100/35/KM 25	SDF100/35/BJM 25	SDF100/35/TBM 25
30		SDF100/35/KM 30	SDF100/35/BJM 30	SDF100/35/TBM 30

LOAD LIMITED BY BEARINGS TO: (1) 1140Kg

Wheels fitted with ball journals are pre-lubricated, double shielded

STEEL DOUBLE FLANGED RAIL

Steel Double Flanged Rail Wheels

WHEEL TYPE:

SDF150/50

See table for full part number

Maximum load rating:

3900Kg

See pages 23-26 for load factors

Approximate weight: **13Kg**

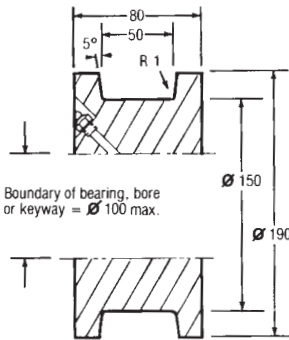

FULL PART NUMBER FOR ORDERING

Axle \varnothing	Plain Bore	Plain Bore Keywayed	Ball Bearing	Taper Roller Bearing
--------------------	------------	---------------------	--------------	----------------------

METRIC AXLE \varnothing				
30		SDF150/50/KM 30	SDF150/50/BJM 30 (1)	SDF150/50/TBM 30
35		SDF150/50/KM 35	SDF150/50/BJM 35 (2)	SDF150/50/TBM 35
40		SDF150/50/KM 40	SDF150/50/BJM 40 (3)	SDF150/50/TBM 40

LOAD LIMITED BY BEARINGS TO: (1) 2040Kg (2) 2800Kg (3) 3384Kg

WHEEL TYPE:

SDF200/50

See table for full part number

Maximum load rating:

5100Kg

See pages 23-26 for load factors

Approximate weight: **25kg**

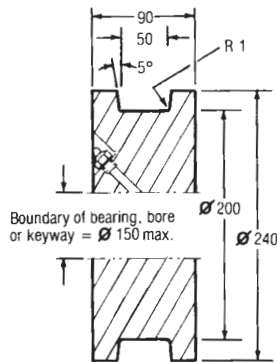

METRIC AXLE \varnothing				
40		SDF200/50/KM 40	SDF200/50/BJM 40 (1)	SDF200/50/TBM 40
50		SDF200/50/KM 50	SDF200/50/BJM 50	SDF200/50/TBM 50

LOAD LIMITED BY BEARINGS TO: (1) 3384Kg

WHEEL TYPE:

SDF225/50

See table for full part number

Maximum load rating:

5800Kg

See pages 23-26 for load factors

Approximate weight: **36Kg**

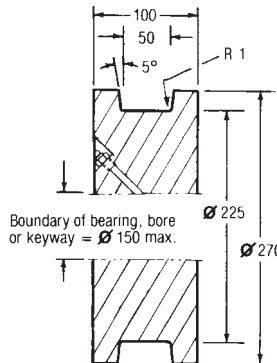

METRIC AXLE \varnothing				
50		SDF225/50/KM 50	SDF225/50/BJM 50	SDF225/50/TBM 50
60		SDF225/50/KM 60	SDF225/50/BJM 60	SDF225/50/TBM 60

WHEEL TYPE:

SDF225/60

See table for full part number

Maximum load rating:

7000Kg

See pages 23-26 for load factors

Approximate weight: **35Kg**

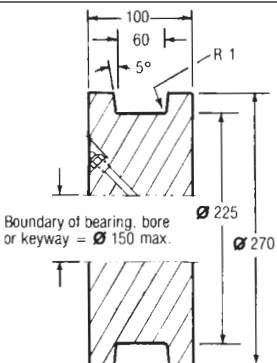

METRIC AXLE \varnothing				
50		SDF225/60/KM 50	SDF225/60/BJM 50	SDF225/60/TBM 50
60		SDF225/60/KM 60	SDF225/60/BJM 60	SDF225/60/TBM 60

Steel Double Flanged Rail Wheels



WHEEL TYPE:
SDF250/60
See table for full part number

Maximum load rating:
7700Kg
See pages 23-26 for load factors
Approximate weight: 44Kg

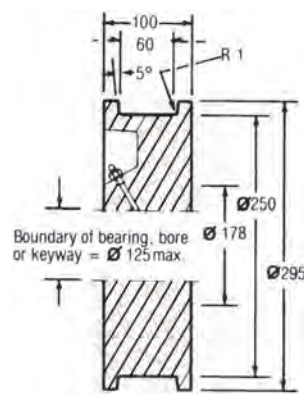

FULL PART NUMBER FOR ORDERING

Axle Ø	Plain Bore	Plain Bore Keywayed	Ball Bearing	Taper Roller Bearing
METRIC AXLE Ø				
50		SDF250/60/KM 50	SDF250/60/BJM 50 (1)	SDF250/60/TBM 50
60		SDF250/60/KM 60	SDF250/60/BJM 60	SDF250/60/TBM 60

LOAD LIMITED BY BEARINGS TO: (1) 7340Kg

WHEEL TYPE:
SDF300/55
See table for full part number

Maximum load rating:
8500Kg
See pages 23-26 for load factors
Approximate weight: 60Kg

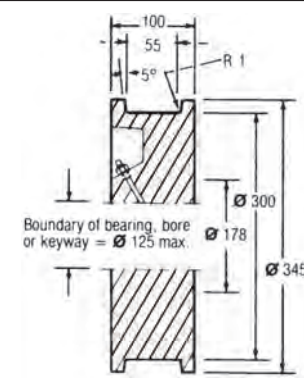

Axle Ø	Plain Bore	Plain Bore Keywayed	Ball Bearing	Taper Roller Bearing
METRIC AXLE Ø				
50		SDF300/55/KM 50	SDF300/55/BJM 50 (1)	SDF300/55/TBM 50
60		SDF300/55/KM 60	SDF300/55/BJM 60	SDF300/55/TBM 60
75		SDF300/55/KM 75	SDF300/55/BJM 75	SDF300/55/TBM 75

LOAD LIMITED BY BEARINGS TO: (1) 7340Kg

WHEEL TYPE:
SDF300/65
See table for full part number

Maximum load rating:
10000Kg
See pages 23-26 for load factors
Approximate weight: 59Kg

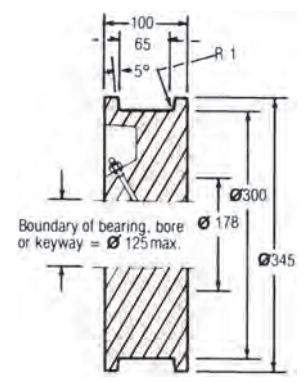

Axle Ø	Plain Bore	Plain Bore Keywayed	Ball Bearing	Taper Roller Bearing
METRIC AXLE Ø				
50		SDF300/65/KM 50		SDF300/65/TBM 50
60		SDF300/65/KM 60	SDF300/65/BJM 60 (1)	SDF300/65/TBM 60
75		SDF300/65/KM 75	SDF300/65/BJM 75 (2)	SDF300/55/TBM 75

LOAD LIMITED BY BEARINGS TO: (1) 9785Kg (2) 9000Kg

WHEEL TYPE:
SDF350/60
See table for full part number

Maximum load rating:
10800Kg
See pages 23-26 for load factors
Approximate weight: 90Kg

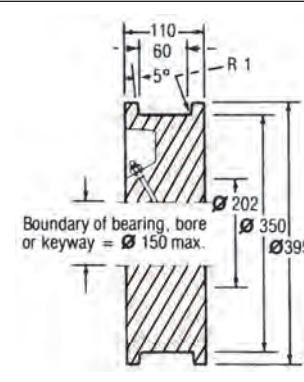

Axle Ø	Plain Bore	Plain Bore Keywayed	Ball Bearing	Taper Roller Bearing
METRIC AXLE Ø				
50		SDF350/60/KM 50		SDF350/60/TBM 50 (3)
60		SDF350/60/KM 60	SDF350/60/BJM 60 (1)	SDF350/60/TBM 60
75		SDF350/60/KM 75	SDF350/60/BJM 75 (2)	SDF350/60/TBM 75

LOAD LIMITED BY BEARINGS TO: (1) 9785Kg (2) 9000Kg (3) 10600Kg

STEEL DOUBLE FLANGED RAIL

Steel Double Flanged Rail Wheels

STEEL DOUBLE FLANGED RAIL

WHEEL TYPE:
SDF350/75

See table for full part number

Maximum load rating:
13500Kg

See pages 23-26 for load factors

Approximate weight: **90Kg**

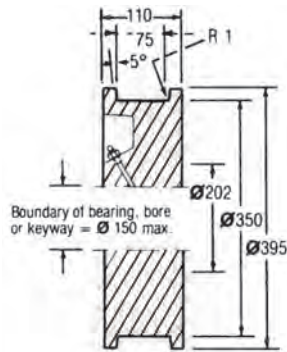

FULL PART NUMBER FOR ORDERING

Axle Ø	Plain Bore	Plain Bore Keywayed	Ball Bearing	Taper Roller Bearing
METRIC AXLE Ø				
60		SDF350/75/KM 60		SDF350/75/TBM 60
75		SDF350/75/KM 75		SDF350/75/TBM 75
100		SDF350/75/KM 100		SDF350/75/TBM 100

LOAD LIMITED BY BEARINGS TO: (1) 13350Kg

WHEEL TYPE:
SDF450/70

See table for full part number

Maximum load rating:
16200Kg

See pages 23-26 for load factors

Approximate weight: **160Kg**

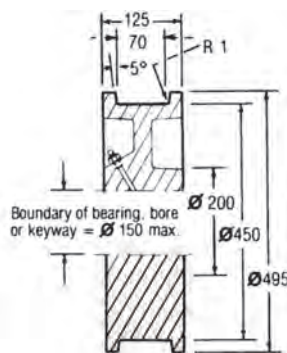

METRIC AXLE Ø				
75		SDF450/70/KM 75		SDF450/70/TBM 75
100		SDF450/70/KM 100		SDF450/70/TBM 100

WHEEL TYPE:
SDF450/80

See table for full part number

Maximum load rating:
18500Kg

See pages 23-26 for load factors

Approximate weight: **160Kg**

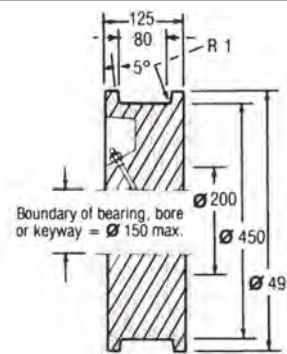

METRIC AXLE Ø				
75		SDF450/80/KM 75		SDF450/80/TBM 75
100		SDF450/80/KM 100		SDF450/80/TBM 100

WHEEL TYPE:
SDF600/100

See table for full part number

Maximum load rating:
30900Kg

See pages 23-26 for load factors

Approximate weight: **350Kg**

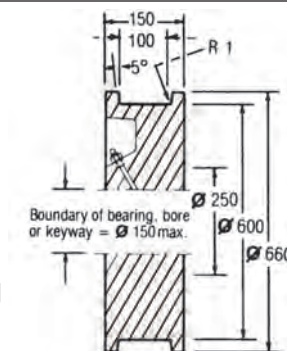

METRIC AXLE Ø				
100		SDF600/100/KM 100		SDF600/100/TBM 100
150		SDF600/100/KM 150		SDF600/100/TBM 150

Cast Iron Double Flanged Rail Wheels



Cast iron rail wheels are the most economic for light to medium duty, but they have a limited service life when compared to steel wheels, and are unsuitable for high rotational speeds or where substantial shock loads are to be withstood.

Flanged wheels can be used for guidance paired with an unflanged rail wheel to allow a wide tolerance in the pitch of the rails.

MATERIAL: Cast iron to BS1452: 1977: Grade 200.

OPERATING TEMPERATURE RANGE:

- Plain bored or keywayed wheels – 30°C to 250°C
- Ball or taper roller bearinged wheels – 30°C to 120°C

The 'maximum load rating' given for each wheel is based on the full tread width being in contact with the rail. Working loads must be calculated based on the useable rail width and operating conditions – see 'Design Data' paras. 6.1. and 6.3.

Alternative bore/bearing diameters and alternative bearing types (i.e. bronze bushes, self-lubricating bushes, roller bearings, spherical roller bearings, etc.) are available to order – see pages 26-27.

For technical information covering load factors, inertial and rolling resistance, coefficients of friction between wheel and track, and keyway dimensions, see "Design Data" Index on page 20.

FULL PART NUMBER FOR ORDERING

Axle Ø	Plain Bore	Plain Bore Keywayed	Ball Bearing	Taper Roller Bearing
METRIC AXLE Ø				
25	CDF130/40/PBM 25	CDF130/40/KM 25	CDF130/40/BJM 25	
30	CDF130/40/PBM 30	CDF130/40/KM 30	CDF130/40/BJM 30	
35	CDF130/40/PBM 35	CDF130/40/KM 35	CDF130/40/BJM 35	

WHEEL TYPE:
CDF130/40
See table for full part number

Maximum load rating:
650Kg
See pages 23-26 for load factors
Approximate weight: 8Kg

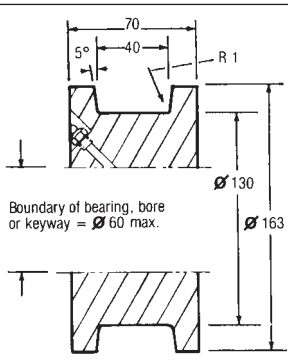

WHEEL TYPE:
CDF150/50
See table for full part number

Maximum load rating:
1000Kg
See pages 23-26 for load factors
Approximate weight: 12Kg

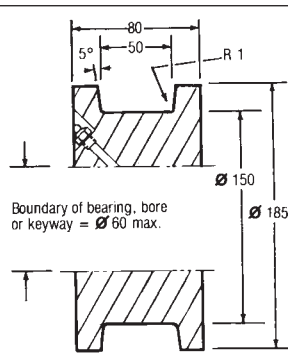

METRIC AXLE Ø				
30	CDF150/50/PBM 30	CDF150/50/KM 30	CDF150/50/BJM 30	
35	CDF150/50/PBM 35	CDF150/50/KM 35	CDF150/50/BJM 35	
40	CDF150/50/PBM 40	CDF150/50/KM 40		

CAST IRON DOUBLE FLANGED RAIL

Cast Iron Double Flanged Rail Wheels

CAST IRON DOUBLE FLANGED RAIL

WHEEL TYPE:

CDF200/45

See table for full part number

Maximum load rating:

1200Kg

See pages 23-26 for load factors

Approximate weight: **16Kg**

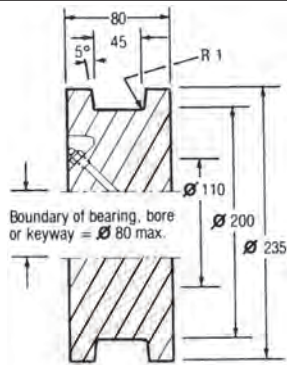

FULL PART NUMBER FOR ORDERING

Axle Ø	Plain Bore	Plain Bore Keywayed	Ball Bearing	Taper Roller Bearing
METRIC AXLE Ø				
30	CDF200/45/PBM 30	CDF200/45/KM 30		
35	CDF200/45/PBM 35	CDF200/45/KM 35	CDF200/45/BJM 35	
40	CDF200/45/PBM 40	CDF200/45/KM 40	CDF200/45/BJM 40	

WHEEL TYPE:

CDF200/55

See table for full part number

Maximum load rating:

1450Kg

See pages 23-26 for load factors

Approximate weight: **18Kg**

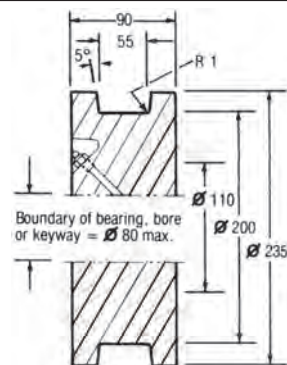

METRIC AXLE Ø				
30	CDF200/55/PBM 30	CDF200/55/KM 30		
35	CDF200/55/PBM 35	CDF200/55/KM 35	CDF200/55/BJM 35	
40	CDF200/55/PBM 40	CDF200/55/KM 40	CDF200/55/BJM 40	

WHEEL TYPE:

CDF250/50

See table for full part number

Maximum load rating:

1650Kg

See pages 23-26 for load factors

Approximate weight: **21Kg**

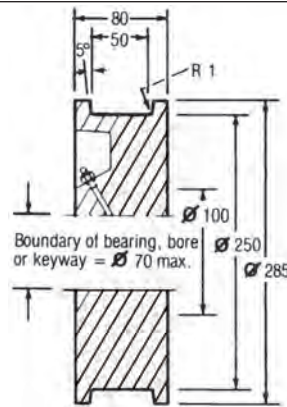

METRIC AXLE Ø				
35	CDF250/50/PBM 35	CDF250/50/KM 35	CDF250/50/BJM 35	
40	CDF250/50/PBM 40	CDF250/50/KM 40	CDF250/50/BJM 40	

WHEEL TYPE:

CDF300/60

See table for full part number

Maximum load rating:

2300Kg

See pages 23-26 for load factors

Approximate weight: **32Kg**

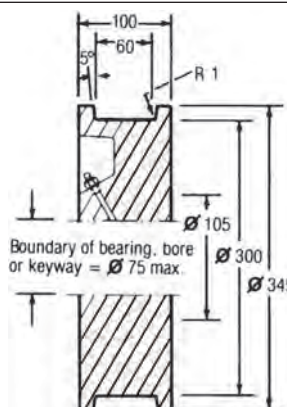

METRIC AXLE Ø				
40	CDF300/60/PBM 40	CDF300/60/KM 40	CDF300/60/BJM 40	
50	CDF300/60/PBM 50	CDF300/60/KM 50		

Steel Flat Tread Rail Wheels

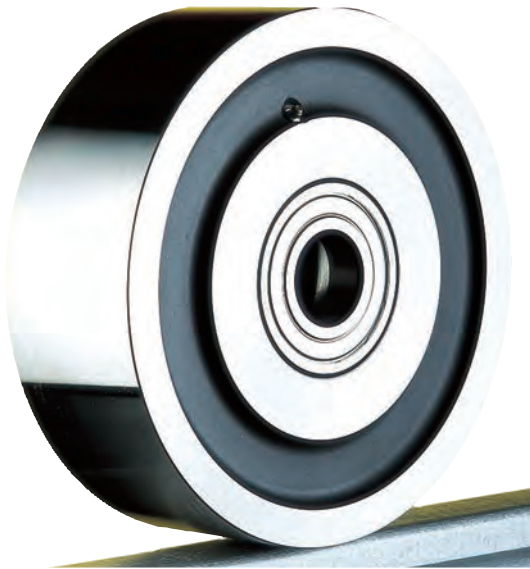

While unflanged wheels can be used to run on surfaces such as concrete or steel plate, their most common application is paired with a double flanged wheel, the flanged wheel providing guidance and the unflanged wheel allowing a wide tolerance in the pitch of the rails.

MATERIAL: Steel to BS970: 1983: 080M40

OPERATING TEMPERATURE RANGE:

- Plain bored or keywayed wheels – 30°C to 350°C
- Ball or taper roller bearinged wheels – 30°C to 120°C

The 'maximum load rating' given for each wheel is based on the full tread width being in contact with the rail. Working loads must be calculated based on the useable rail width and operating conditions – see 'Design Data' paras. 6.1. and 6.2.

Alternative bore/bearing diameters and alternative bearing types (i.e. bronze bushes, self-lubricating bushes, roller bearings, spherical roller bearings, etc.) are available to order – see pages 26-27.

Plain bore wheels are not drilled and tapped for greasing unless requested at time of order.

For technical information covering load factors, inertial and rolling resistance, coefficients of friction between wheel and track, and keyway dimensions, see "Design Data" Index on page 20.

FULL PART NUMBER FOR ORDERING

Axle Ø	Plain Bore	Plain Bore Keywayed	Ball Bearing	Taper Roller Bearing
METRIC AXLE Ø				
25		SFT75/60/KM 25	SFT75/60/BJM 25 ⁽¹⁾	SFT75/60/TBM 25
30		SFT75/60/KM 30	SFT75/60/BJM 30 ⁽²⁾	SFT75/60/TBM 30

LOAD LIMITED BY BEARINGS TO: (1) 1140Kg (2) 2040Kg

WHEEL TYPE:

SFT75/60

See table for full part number

Maximum load rating:
2300Kg

See pages 23-26 for load factors

Approximate weight: 2Kg

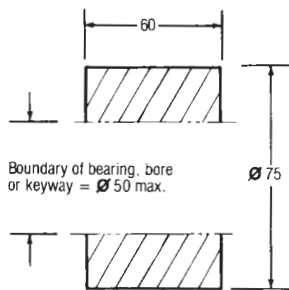

Wheels fitted with ball journals are pre-lubricated, double shielded

WHEEL TYPE:

SFT100/60

See table for full part number

Maximum load rating:
3100Kg

See pages 23-26 for load factors

Approximate weight: 3.5Kg

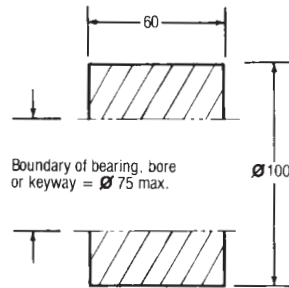

Wheels fitted with ball journals are pre-lubricated, double shielded

METRIC AXLE Ø				
25		SFT100/60/KM 25	SFT100/60/BJM 25 ⁽¹⁾	SFT100/60/TBM 25
30		SFT100/60/KM 30	SFT100/60/BJM 30 ⁽²⁾	SFT100/60/TBM 30

LOAD LIMITED BY BEARINGS TO: (1) 1140Kg (2) 2040Kg

STEEL FLAT TREAD RAIL

Steel Flat Tread Rail Wheels

STEEL FLAT TREAD RAIL

WHEEL TYPE:
SFT150/80

See table for full part number

Maximum load rating:
6200Kg

See pages 23-26 for load factors

Approximate weight: 10Kg

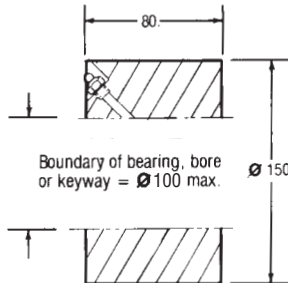

FULL PART NUMBER FOR ORDERING

Axle Ø	Plain Bore	Plain Bore Keywayed	Ball Bearing	Taper Roller Bearing
METRIC AXLE Ø				
30		SFT150/80/KM 30	SFT150/80/BJM 30 (1)	SFT150/80/TBM 30 (4)
35		SFT150/80/KM 35	SFT150/80/BJM 35 (2)	SFT150/80/TBM 35
40		SFT150/80/KM 40	SFT150/80/BJM 40 (3)	SFT150/80/TBM 40

LOAD LIMITED BY BEARINGS TO: (1) 2040Kg (2) 2800Kg (3) 3384Kg (4) 5200Kg

WHEEL TYPE:
SFT200/90

See table for full part number

Maximum load rating:
9300Kg

See pages 23-26 for load factors

Approximate weight: 22Kg

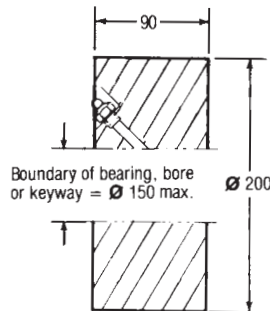

METRIC AXLE Ø				
40		SFT200/90/KM 40	SFT200/90/BJM 40 (1)	SFT200/90/TBM 40 (3)
50		SFT200/90/KM 50	SFT200/90/BJM 50 (2)	SFT200/90/TBM 50

LOAD LIMITED BY BEARINGS TO: (1) 3384Kg (2) 7340Kg (3) 8155Kg

WHEEL TYPE:
SFT225/100

See table for full part number

Maximum load rating:
11600Kg

See pages 23-26 for load factors

Approximate weight: 30Kg

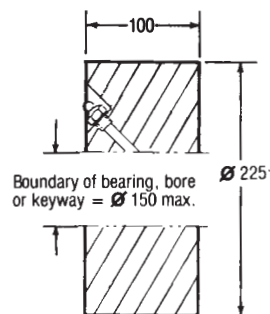

METRIC AXLE Ø				
50		SFT225/100/KM 50	SFT225/100/BJM 50 (1)	SFT225/100/TBM 50 (3)
60		SFT225/100/KM 60	SFT225/100/BJM 60 (2)	SFT225/100/TBM 60

LOAD LIMITED BY BEARINGS TO: (1) 7340Kg (2) 9785Kg (3) 10600Kg

WHEEL TYPE:
SFT250/100

See table for full part number

Maximum load rating:
12900Kg

See pages 23-26 for load factors

Approximate weight: 37Kg

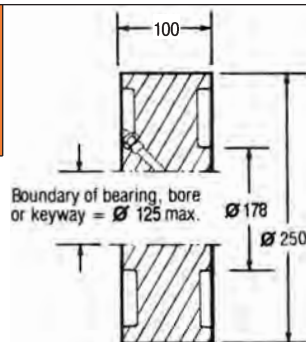

METRIC AXLE Ø				
50		SFT250/100/KM 50	SFT250/100/BJM 50 (1)	SFT250/100/TBM 50 (4)
60		SFT250/100/KM 60	SFT250/100/BJM 60 (2)	SFT250/100/TBM 60
75		SFT250/100/KM 75	SFT250/100/BJM 75 (3)	SFT250/100/TBM 75

LOAD LIMITED BY BEARINGS TO: (1) 7340Kg (2) 9785Kg (3) 9000Kg (4) 10600Kg

Steel Flat Tread Rail Wheels



WHEEL TYPE: SFT300/100

See table for full part number

Maximum load rating:
15400Kg

See pages 23-26 for load factors

Approximate weight: **54Kg**

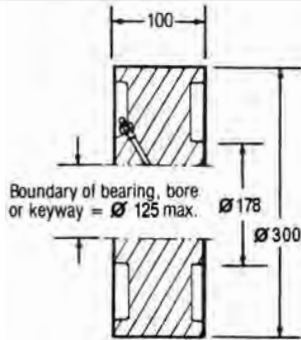

FULL PART NUMBER FOR ORDERING

Axle Ø	Plain Bore	Plain Bore Keywayed	Ball Bearing	Taper Roller Bearing
--------	------------	---------------------	--------------	----------------------

METRIC AXLE Ø				
50		SFT300/100/KM 50	SFT300/100/BJM 50 (1)	SFT300/100/TBM 50 (4)
60		SFT300/100/KM 60	SFT300/100/BJM 60 (2)	SFT300/100/TBM 60 (5)
75		SFT300/100/KM 75	SFT300/100/BJM 75 (3)	SFT300/100/TBM 75

LOAD LIMITED BY BEARINGS TO: (1) 7340Kg (2) 9785Kg (3) 9000Kg (4) 10600Kg
(5) 13350Kg

WHEEL TYPE: SFT350/110

See table for full part number

Maximum load rating:
19900Kg

See pages 23-26 for load factors

Approximate weight: **80Kg**

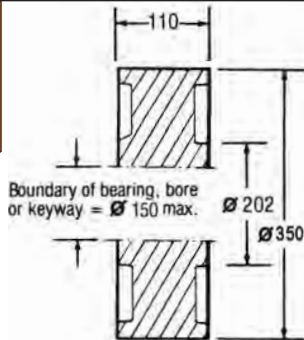

METRIC AXLE Ø				
50		SFT350/110/KM 50	SFT350/110/BJM 50 (1)	SFT350/110/TBM 50 (4)
60		SFT350/110/KM 60	SFT350/110/BJM 60 (2)	SFT350/110/TBM 60 (5)
75		SFT350/110/KM 75	SFT350/110/BJM 75 (3)	SFT350/110/TBM 75 (6)

LOAD LIMITED BY BEARINGS TO: (1) 7340Kg (2) 9785Kg (3) 9000Kg (4) 10600Kg
(5) 13350Kg (6) 19400Kg

WHEEL TYPE: SFT450/125

See table for full part number

Maximum load rating:
29000Kg

See pages 23-26 for load factors

Approximate weight: **150Kg**

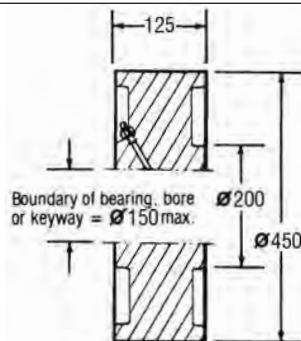

METRIC AXLE Ø				
75		SFT450/125/KM 75		SFT450/125/TBM 75 (1)
100		SFT450/125/KM 100		SFT450/125/TBM 100

LOAD LIMITED BY BEARINGS TO: (1) 19400Kg

WHEEL TYPE: SFT600/150

See table for full part number

Maximum load rating:
46300Kg

See pages 23-26 for load factors

Approximate weight: **325Kg**

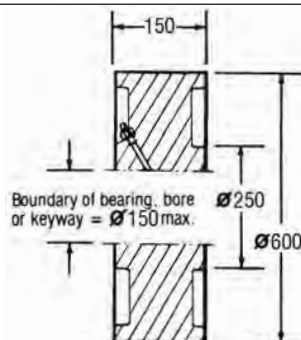

METRIC AXLE Ø				
100		SFT600/150/KM 100		SFT600/150/TBM 100 (1)
150		SFT600/150/KM 150		SFT600/150/TBM 150

LOAD LIMITED BY BEARINGS TO: (1) 31000Kg

Cast Iron Flat Tread Rail Wheels

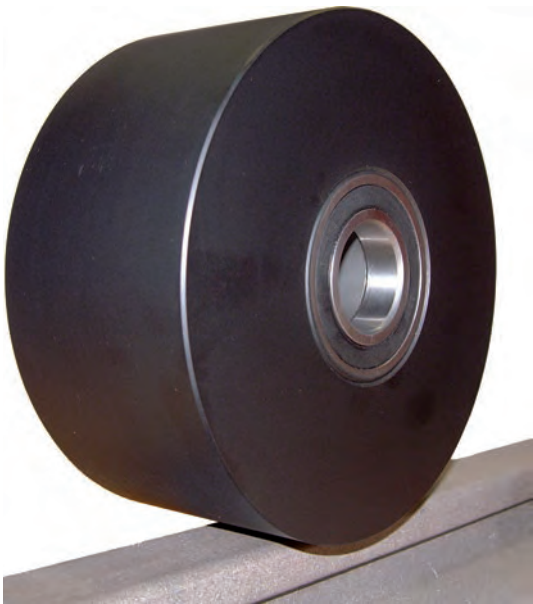

While unflanged wheels can be used to run on surfaces such as concrete or steel plate, their most common application is paired with a double flanged wheel.

Cast iron rail wheels are the most economic for light to medium duty, but they have a limited service life when compared to steel wheels, and are unsuitable for high rotational speeds or where substantial shock loads are to be withstood.

MATERIAL: Cast iron to BS1452: 1977: Grade 200.

OPERATING TEMPERATURE RANGE:

Plain bored or keywayed wheels – 30°C to 250°C

Ball or taper roller bearinged wheels – 30°C to 120°C

The 'maximum load rating' given for each wheel is based on the full tread width being in contact with the rail. Working loads must be calculated based on the useable rail width and operating conditions – see 'Design Data' paras. 6.1. and 6.3.

Alternative bore/bearing diameters and alternative bearing types (i.e. bronze bushes, self-lubricating bushes, roller bearings, spherical roller bearings, etc.) are available to order – see page 26-27.

For technical information covering load factors, inertial and rolling resistance, coefficients of friction between wheel and track, and keyway dimensions, see "Design Data" Index on page 20.

CAST IRON FLAT TREAD RAIL

WHEEL TYPE:
CFT130/70
See table for full part number

Maximum load rating:
1200Kg

See pages 23-26 for load factors

Approximate weight: 7Kg

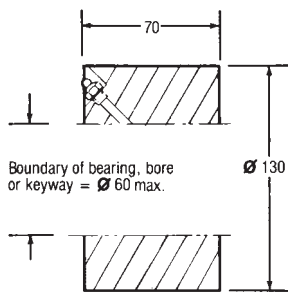

Wheels fitted with 35mm ball journals are pre-lubricated, double shielded

WHEEL TYPE:
CFT150/80
See table for full part number

Maximum load rating:
1500Kg

See pages 23-26 for load factors

Approximate weight: 10Kg

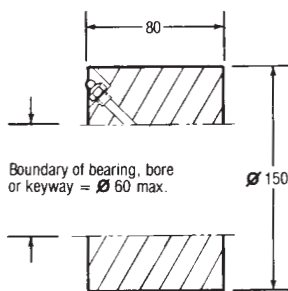

FULL PART NUMBER FOR ORDERING

Axle Ø	Plain Bore	Plain Bore Keywayed	Ball Bearing	Taper Roller Bearing
METRIC AXLE Ø				
25	CFT130/70/PBM 25	CFT130/70/KM 25	CFT130/70/BJM 25	
30	CFT130/70/PBM 30	CFT130/70/KM 30	CFT130/70/BJM 30	
35	CFT130/70/PBM 35	CFT130/70/KM 35	CFT130/70/BJM 35	

LOAD LIMITED BY BEARINGS TO: (1) 1140Kg

METRIC AXLE Ø				
30	CFT150/80/PBM 30	CFT150/80/KM 30	CFT150/80/BJM 30	
35	CFT150/80/PBM 35	CFT150/80/KM 35	CFT150/80/BJM 35	
40	CFT150/80/PBM 40	CFT150/80/KM 40	CFT150/80/BJM 40	

Cast Iron Flat Tread Rail Wheels



WHEEL TYPE:
CFT200/90
See table for full part number

Maximum load rating:
2300Kg
See pages 23-26 for load factors
Approximate weight: 14Kg

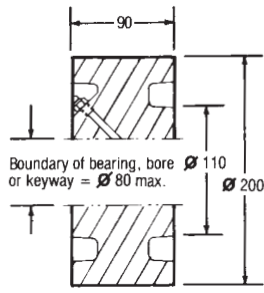

FULL PART NUMBER FOR ORDERING

Axle Ø	Plain Bore	Plain Bore Keywayed	Ball Bearing	Taper Roller Bearing
METRIC AXLE Ø				
30	CFT200/90/PBM 30	CFT200/90/KM 30	CFT200/90/BJM 30	
35	CFT200/90/PBM 35	CFT200/90/KM 35	CFT200/90/BJM 35	
40	CFT200/90/PBM 40	CFT200/90/KM 40	CFT200/90/BJM 40	

LOAD LIMITED BY BEARINGS TO: (1) 2040Kg

WHEEL TYPE:
CFT250/80
See table for full part number

Maximum load rating:
2600Kg
See pages 23-26 for load factors
Approximate weight: 18Kg

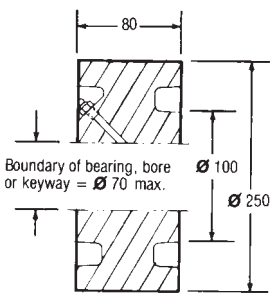

METRIC AXLE Ø

35	CFT250/80/PBM 35	CFT250/80/KM 35	CFT250/80/BJM 35	
40	CFT250/80/PBM 40	CFT250/80/KM 40	CFT250/80/BJM 40	

WHEEL TYPE:
CFT300/100
See table for full part number

Maximum load rating:
4000Kg
See pages 23-26 for load factors
Approximate weight: 27Kg

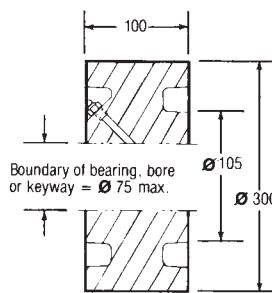

METRIC AXLE Ø

40	CFT300/100/PBM 40	CFT300/100/KM 40	CFT300/100/BJM 40	
50	CFT300/100/PBM 50	CFT300/100/KM 50		

LOAD LIMITED BY BEARINGS TO: (1) 3384Kg

CAST IRON FLAT TREAD RAIL

Cast Nylon Flat Tread Rail Wheels



Nylon wheels are light in weight and are resistant to impact, abrasion, corrosion and the effect of many chemicals.

While unflanged wheels can be used to run on surfaces such as concrete or steel plate, their most common application is paired with a double flanged wheel, the flanged wheel providing guidance and the unflanged wheel allowing a wide tolerance in the pitch of the rails.

MATERIAL: Cast Nylon 6

OPERATING TEMPERATURE RANGE:

Plain bored or keywayed wheels – 30°C to 80°C

Ball or taper roller bearinged wheels – 30°C to 80°C

The 'maximum load rating' given for each wheel is based on the full tread width being in contact with the rail. Working loads must be calculated based on the useable rail width and operating conditions – see 'Design Data' paras. 6.1. and 6.2.

Alternative bore/bearing diameters and alternative bearing types (i.e. bronze bushes, self-lubricating bushes, roller bearings, spherical roller bearings, etc.) are available to order – see pages 26-27.

Plain bore wheels are not drilled and tapped for greasing unless requested at time of order.

For technical information covering load factors, inertial and rolling resistance, coefficients of friction between wheel and track, and keyway dimensions, see "Design Data" Index on page 20.

WHEEL TYPE:
NFT200/60

See table for full part number

Maximum load rating:

2350Kg

See page 21 for load factors

Approximate weight: **2Kg**

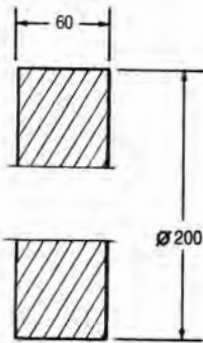

FULL PART NUMBER FOR ORDERING

Axle Ø	Plain Bore	Ball Bearing
METRIC AXLE Ø		
30	NFT200/60/PBM30	NFT200/60/BJM30
35	NFT200/60/PBM35	

LOAD LIMITED BY BEARINGS TO: (1) 2040Kg

WHEEL TYPE:
NFT250/60

See table for full part number

Maximum load rating:

2950Kg

See page 21 for load factors

Approximate weight: **3.2Kg**

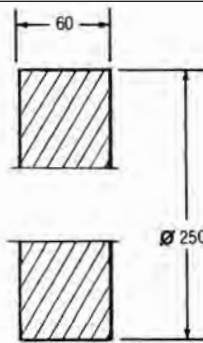

METRIC AXLE Ø		
35	NFT250/60/PBM35	
40	NFT250/60/PBM40	NFT250/60/BJM40
50	NFT250/60/PBM50	

LOAD LIMITED BY BEARINGS TO: (1) 3384Kg

WHEEL TYPE:
NFT250/75

See table for full part number

Maximum load rating:

3680Kg

See page 21 for load factors

Approximate weight: **4Kg**

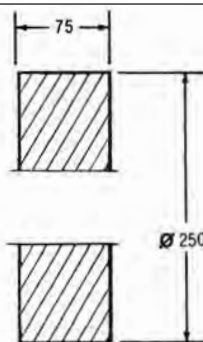

METRIC AXLE Ø		
35	NFT250/75/PBM35	
40	NFT250/75/PBM40	NFT250/75/BJM40
50	NFT250/75/PBM50	

LOAD LIMITED BY BEARINGS TO: (1) 3384Kg

Cast Nylon Flat Tread Rail Wheels

BRAUER[®]

**WHEEL TYPE:
NFT250/100**

See table for full part number

Maximum load rating:
4900Kg

See page 21 for load factors

Approximate weight: **5.5Kg**

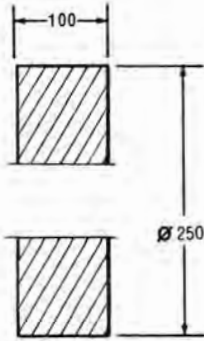

FULL PART NUMBER FOR ORDERING

Axle Ø	Plain Bore	Ball Bearing
METRIC AXLE Ø		
35	NFT250/100/PBM35	
40	NFT250/100/PBM40	
50	NFT250/100/PBM50	NFT250/100/BJM50

LOAD LIMITED BY BEARINGS TO: (1) 4729Kg

**WHEEL TYPE:
NFT300/100**

See table for full part number

Maximum load rating:
5880Kg

See page 21 for load factors

Approximate weight: **8Kg**

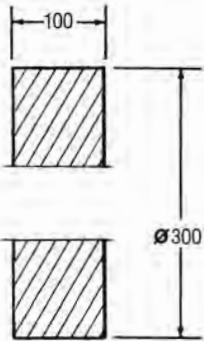

METRIC AXLE Ø		
50	NFT300/100/PBM50	
60	NFT300/100/PBM60	NFT300/100/BJM60

**WHEEL TYPE:
NFT350/100**

See table for full part number

Maximum load rating:
6870Kg

See page 21 for load factors

Approximate weight: **10.5Kg**

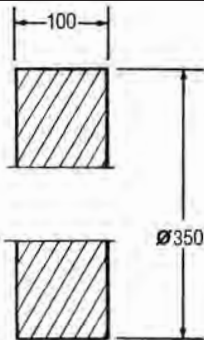

METRIC AXLE Ø		
60	NFT350/100/PBM60	NFT350/100/BJM60
75	NFT350/100/PBM75	

**WHEEL TYPE:
NFT400/100**

See table for full part number

Maximum load rating:
7850Kg

See page 21 for load factors

Approximate weight: **14Kg**

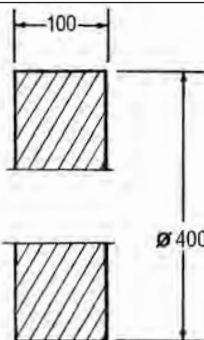

METRIC AXLE Ø		
75	NFT400/100/PBM75	NFT400/100/BJM75

CAST NYLON RANGE

Cast Nylon Double Flanged Rail Wheels



Nylon wheels are light in weight and are resistant to impact, abrasion, corrosion and the effect of many chemicals.

Flanged wheels can be used for guidance paired with an unflanged rail wheel to allow a wide tolerance in the pitch of the rails.

MATERIAL: Cast Nylon 6

OPERATING TEMPERATURE RANGE:

Plain bored or keywayed wheels – 30°C to 80°C

Ball or taper roller bearinged wheels – 30°C to 80°C

The 'maximum load rating' given for each wheel is based on the full tread width being in contact with the rail. Working loads must be calculated based on the useable rail width and operating conditions – see 'Design Data' paras. 6.1. and 6.2.

Alternative bore/bearing diameters and alternative bearing types (i.e. bronze bushes, self-lubricating bushes, roller bearings, spherical roller bearings, etc.) are available to order – see pages 23-28.

Plain bore wheels are not drilled and taped for greasing unless requested at time of order.

For technical information covering load factors, inertial and rolling resistance, coefficients of friction between wheel and track, and keyway dimensions, see "Design Data" Index on page 20.

CAST NYLON RANGE

WHEEL TYPE:
NDF200/60
See table for full part number

Maximum load rating:
1960Kg
See page 21 for load factors
Approximate weight: 4Kg

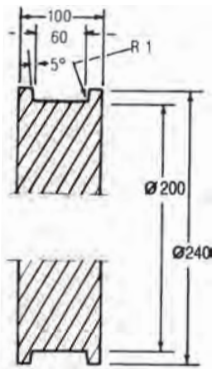

FULL PART NUMBER FOR ORDERING

Axle Ø	Plain Bore	Ball Bearing
METRIC AXLE Ø		
25	NDF200/60/PBM25	NDF200/60/BJM25
30	NDF200/60/PBM30	

LOAD LIMITED BY BEARINGS TO: (1) 1140Kg

WHEEL TYPE:
NDF250/60
See table for full part number

Maximum load rating:
2453Kg
See page 21 for load factors
Approximate weight: 5.5Kg

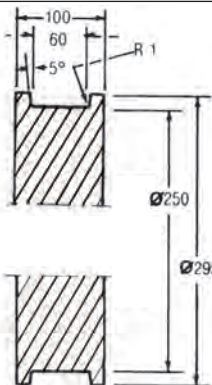

METRIC AXLE Ø		
30	NDF250/60/PBM30	NDF250/60/BJM30
35	NDF250/60/PBM35	

LOAD LIMITED BY BEARINGS TO: (1) 2040Kg

Cast Nylon Double Flanged Rail Wheels



WHEEL TYPE:
NDF300/60

See table for full part number

Maximum load rating:
3530Kg

See page 21 for load factors

Approximate weight: 8Kg

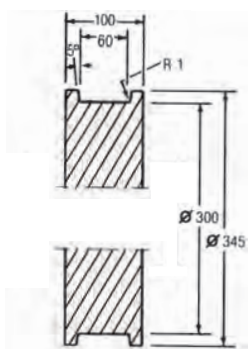

FULL PART NUMBER FOR ORDERING

Axle Ø	Plain Bore	Ball Bearing
METRIC AXLE Ø		
40	NDF300/60/PBM40	NDF300/60/BJM40
50	NDF300/60/PBM50	

LOAD LIMITED BY BEARINGS TO: (1) 3384Kg

WHEEL TYPE:
NDF350/60

See table for full part number

Maximum load rating:
4120Kg

See page 21 for load factors

Approximate weight: 11Kg

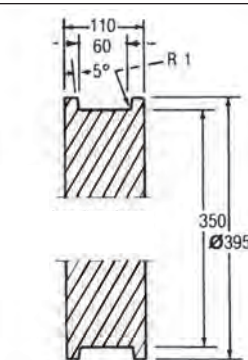

METRIC AXLE Ø		
50	NDF350/60/PBM50	NDF350/60/BJM50
60	NDF350/60/PBM60	

WHEEL TYPE:
NDF400/60

See table for full part number

Maximum load rating:
4770Kg

See page 21 for load factors

Approximate weight: 14Kg

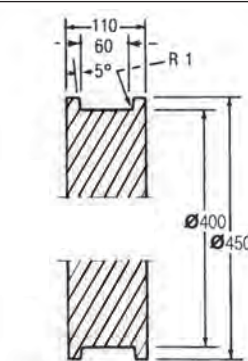

METRIC AXLE Ø		
50	NDF400/60/PBM50	NDF400/60/BJM50
60	NDF400/60/PBM60	

LOAD LIMITED BY BEARINGS TO: (1) 4729Kg

CAST NYLON RANGE



Steel 90° 'V' grooved wheels offer an economic form of rail guidance being suitable for running on inverted angle iron rail.

MATERIAL: Steel to BS970: Part 1: 1983: 080 M40

Alternative bore/bearing diameters and alternative bearing types (i.e. bronze bushers, self-lubricating bushes, high temperature bearings, spherical roller bearings, etc.) are available to order. See page 26-27.

For technical information covering load factors, inertial and rolling resistance, coefficients of friction between wheel and track and keyway dimensions, see "Design Data" Index on page 20.

FULL PART NUMBER FOR ORDERING

Axle Ø	Plain Bore	Plain Bore Keywayed	Ball Bearing	Taper Roller Bearing
METRIC AXLE Ø				
12		SVT75/35/KM 12	SVT75/35/BJM 12	
20		SVT75/35/KM 20	SVT75/35/BJM 20	

LOAD LIMITED BY BEARINGS TO: (1) 570Kg

WHEEL TYPE:

SVT75/35

See table for full part number

Maximum load rating:

800Kg

See pages 23-26 for load factors

Approximate weight: **1Kg**

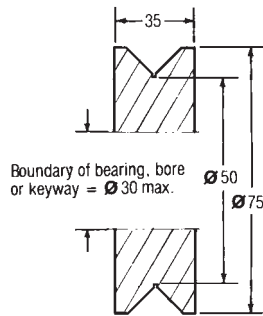

Wheels fitted with ball journals are pre-lubricated, double shielded

WHEEL TYPE:

SVT100/40

See table for full part number

Maximum load rating:

1100Kg

See pages 23-26 for load factors

Approximate weight: **2Kg**

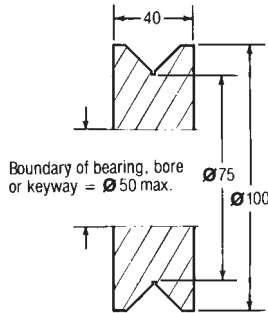

Wheels fitted with ball journals are pre-lubricated, double shielded

WHEEL TYPE:

SVT125/40

See table for full part number

Maximum load rating:

1500Kg

See pages 23-26 for load factors

Approximate weight: **3.4Kg**

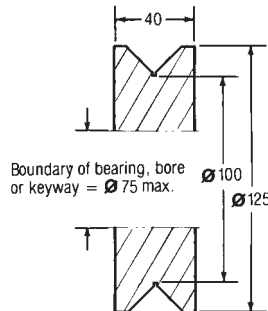

Wheels fitted with ball journals are pre-lubricated, double shielded

METRIC AXLE Ø

20		SVT100/40/KM 20	SVT100/40/BJM 20	
25		SVT100/40/KM 25	SVT100/40/BJM 25	

LOAD LIMITED BY BEARINGS TO: (1) 900Kg

METRIC AXLE Ø

20		SVT125/40/KM 20	SVT125/40/BJM 20	
25		SVT125/40/KM 25	SVT125/40/BJM 25	
30		SVT125/40/KM 30	SVT125/40/BJM 30	

LOAD LIMITED BY BEARINGS TO: (1) 900Kg (2) 1140Kg

Steel 'V' Grooved Wheels



FULL PART NUMBER FOR ORDERING

Axle Ø	Plain Bore	Plain Bore Keywayed	Ball Bearing	Taper Roller Bearing
--------	------------	---------------------	--------------	----------------------

WHEEL TYPE:
SVT150/45
See table for full part number

Maximum load rating:
2200Kg
See pages 23-26 for load factors
Approximate weight: 5.2kg

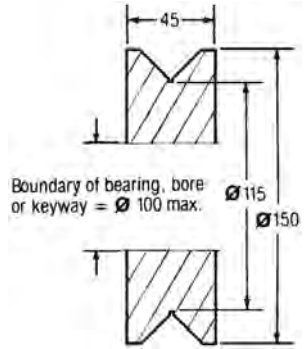

METRIC AXLE Ø				
25		SVT150/45/KM 25	SVT150/45/BJM 25	
30		SVT150/45/KM 30	SVT150/45/BJM 30	
35		SVT150/45/KM 35	SVT150/45/BJM 35	

LOAD LIMITED BY BEARINGS TO: (1) 1140Kg (2) 2040Kg

WHEEL TYPE:
SVT200/50
See table for full part number

Maximum load rating:
3000Kg
See pages 23-26 for load factors
Approximate weight: 11Kg

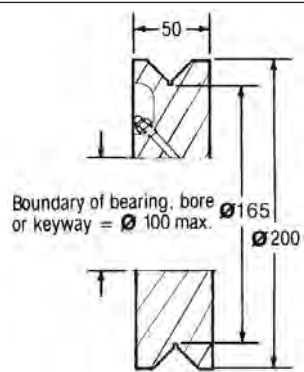

METRIC AXLE Ø				
30		SVT200/50/KM 30	SVT200/50/BJM 30	
35		SVT200/50/KM 35	SVT200/50/BJM 35	
40		SVT200/50/KM 40	SVT200/50/BJM 40	

LOAD LIMITED BY BEARINGS TO: (1) 2040Kg (2) 2800Kg

WHEEL TYPE:
SVT250/60
See table for full part number

Maximum load rating:
4750Kg
See pages 23-26 for load factors
Approximate weight: 23Kg

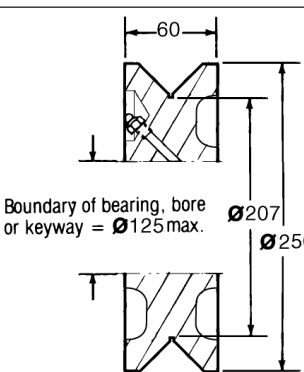

METRIC AXLE Ø				
35		SVT250/60/KM 35	SVT250/60/BJM 35	
40		SVT250/60/KM 40	SVT250/60/BJM 40	
50		SVT250/60/KM 50	SVT250/60/BJM 50	

LOAD LIMITED BY BEARINGS TO: (1) 2800Kg (2) 3384Kg

WHEEL TYPE:
SVT300/70
See table for full part number

Maximum load rating:
7100Kg
See pages 23-26 for load factors
Approximate weight: 38Kg

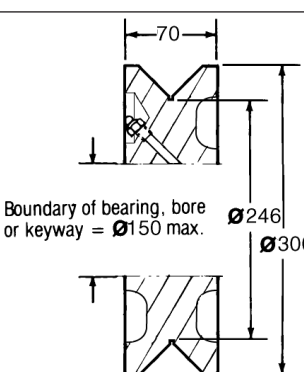

METRIC AXLE Ø				
40		SVT300/70/KM 40	SVT300/70/BJM 40	
50		SVT300/70/KM 50	SVT300/70/BJM 50	
60		SVT300/70/KM 60	SVT300/70/BJM 60	

LOAD LIMITED BY BEARINGS TO: (1) 3384Kg

STEEL 'V' GROOVED

Polyurethane Tyred Single Flanged Rail Wheels



Standard wheel features flanges with a 5° angle and a 'flat tread' (ie tread parallel to the wheel axis) for running on flat top rail. Polyurethane is resilient, durable material, resistant to abrasion and to many common chemicals. Polyurethane tyred wheels are capable of carrying heavy loads and of transmitting driving forces.

MATERIAL: Wheel Centre - Steel to BS970: Part 1: 1983: 080M40
Tyre - Polyester Based Polymer of 92° ± 3° Shore A Hardness

OPERATING TEMPERATURE RANGE:
-20°C to + 60°C (115°C for limited use)

PLEASE SPECIFY IF OPERATING IN HIGH HUMIDITY.

Anti-hydrolysis polyurethane is recommended for use in an operating environment of high humidity.

Polyurethane to the above hardness used on these wheels is Vulkollan, a high quality material that provides superior performance in most applications.

Should the mechanical properties of Vulkollan be inappropriate for the application, alternative grades of Polyurethane can be produced to meet the requirements. Polyurethane can be bonded onto most metal centres including aluminium, titanium, stainless steel and various ferrous and non-ferrous alloys.

The 'Maximum Load Rating' given for each wheel assumes the full tread width is in contact with the rail. In practice full contact with the rail across the tread width is rarely achieved due to:-

- a) Flange to rail clearance
- b) Wheel Overhang
- c) Rail Corner Radii

For calculation of the 'Maximum Allowable Load' see 'Design Data' Para 6.1

In addition the 'Maximum Load Rating' given for each wheel is for operation under ideal conditions.

Load factors must be applied according to the anticipated working conditions - see 'Design Data' Para 5.1

Alternative Bore/Bearing diameters and alternative bearing types (i.e) bronze bushes, self lubricating bushes, etc.) are available to order - see page 26-27.

For technical information covering load factors, inertial and rolling resistance, chemical resistance, coefficients of friction between wheel and track and keyway dimensions, see 'Data Design' index on page 20.

POLYURETHANE TYRED SINGLE-FLANGED

WHEEL TYPE:
SFH100/40
See table for full part number

Maximum load rating:
450Kg
See 'Design Data' paras 5.1 and 6.1 for 'Maximum Allowable Load'.

Approximate weight: 2.7Kg

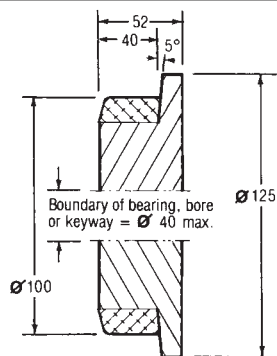

FULL PART NUMBER FOR ORDERING				
Axle Ø	Plain Bore	Plain Bore Keywayed	Ball Bearing	Taper Roller Bearing
METRIC AXLE Ø				
12		SFH100/40/KM 12	SFH100/40/BJM 12	
20		SFH100/40/KM 20	SFH100/40/BJM 20	
25		SFH100/40/KM 25	SFH100/40/BJM 25	
30		SFH100/40/KM 30		

Wheels fitted with ball journals are pre-lubricated, double shielded. Alternatively greasing can be through the axle – state if this option is required when ordering.

Polyurethane Tyred Single Flanged Rail Wheels



WHEEL TYPE: SFH125/45

See table for full part number

**Maximum load rating:
650Kg**

See 'Design Data' paras 5.1 and 6.1 for 'Maximum Allowable Load'.

Approximate weight: 4.7Kg

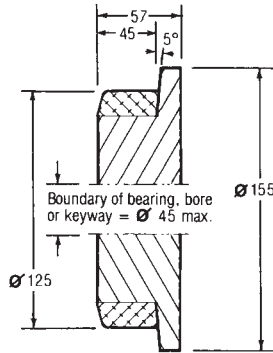

Wheels fitted with ball journals are pre-lubricated, double shielded. Alternatively greasing can be through the axle – state if this option is required when ordering.

WHEEL TYPE: SFH150/50

See table for full part number

**Maximum load rating:
850Kg**

See 'Design Data' paras 5.1 and 6.1 for 'Maximum Allowable Load'.

Approximate weight: 7.6Kg

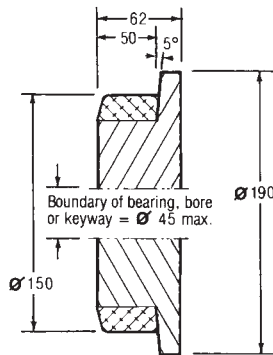

Wheels fitted with ball journals are pre-lubricated, double shielded. Alternatively greasing can be through the axle – state if this option is required when ordering.

WHEEL TYPE: SFH200/60

See table for full part number

**Maximum load rating:
1400Kg**

See 'Design Data' paras 5.1 and 6.1 for 'Maximum Allowable Load'.

Approximate weight: 17Kg

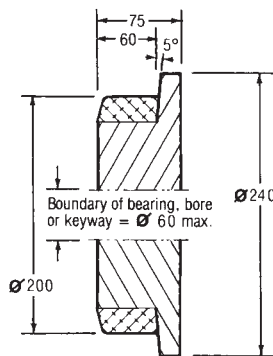

Wheels fitted with ball journals are pre-lubricated, double shielded. Alternatively greasing can be through the axle – state if this option is required when ordering.

FULL PART NUMBER FOR ORDERING

Axle Ø	Plain Bore	Plain Bore Keywayed	Ball Bearing	Taper Roller Bearing
METRIC AXLE Ø				
12		SFH125/45/KM 12	SFH125/45/BJM 12	
20		SFH125/45/KM 20	SFH125/45/BJM 20	
25		SFH125/45/KM 25	SFH125/45/BJM 25	
30		SFH125/45/KM 30	SFH125/45/BJM 30	

LOAD LIMITED BY BEARINGS TO: (1) 570Kg

METRIC AXLE Ø				
20		SFH150/50/KM 20	SFH150/50/BJM 20	
25		SFH150/50/KM 25	SFH150/50/BJM 25	
30		SFH150/50/KM 30	SFH150/50/BJM 30	
35		SFH150/50/KM 35	SFH150/50/BJM 35	

METRIC AXLE Ø				
25		SFH200/60/KM 25	SFH200/60/BJM 25	
30		SFH200/60/KM 30	SFH200/60/BJM 30	
35		SFH200/60/KM 35	SFH200/60/BJM 35	
40		SFH200/60/KM 40	SFH200/60/BJM 40	

LOAD LIMITED BY BEARINGS TO: (1) 1140Kg

POLYURETHANE TYRED SINGLE-FLANGED

Single Flanged 'I' Beam & Channel Wheels - Flat Tread



Brauer has added a flat version to its popular "I" beam and channel radiused tread and wheel range. The new steel, **flat tread**, single flanged range is designed to suit parallel flanged channels and universal beams (to BS4, Part I 1993). The axles have been significantly upgraded to increase the load carrying capacity of the assembly.

MATERIAL: Steel to BS970: Part 1: 1983: 080M40

OPERATING TEMPERATURE RANGE:

-30°C to 120°C.

When shock loadings are to be withstood the 'maximum load rating' should be reduced by multiplying by a shock loading factor of 0.65.

SINGLE FLANGED 'I' BEAM & CHANNEL

PART NUMBER:
SSFF55/25/BJA

Maximum load rating:
370Kg

See pages 23-26 for load factors
Approximate weight: 1.1Kg

PART NUMBER:
SSFF150/35/BJA

Maximum load rating:
1500Kg

See pages 23-26 for load factors
Approximate weight: 7.5Kg

PART NUMBER:
SSFF80/25/BJA

Maximum load rating:
700Kg

See pages 23-26 for load factors
Approximate weight: 2Kg

PART NUMBER:
SSFF200/35/BJA

Maximum load rating:
2000Kg

See pages 23-26 for load factors
Approximate weight: 12Kg

PART NUMBER:
SSFF100/25/BJA

Maximum load rating:
1000Kg

See pages 23-26 for load factors
Approximate weight: 4Kg

Single Flanged 'I' Beam & Channel Wheels - Radius Tread

BRAUER[®]



The SFR (cast iron) and SSFR (Steel) ranges of wheel assemblies have been designed to fit within standard sections of channel and 'I' beams. The radiused tread accommodates the angle of the section and improves the wear and tracking characteristics.

MATERIAL: SFR series – Cast iron to BS1452: 1977: Grade 200
 SSFR series – Steel to BS970: Part 1: 1983: 080M40
 Axles – Steel to BS970: Part 1: 1983: 606M36 or 605M36

OPERATING TEMPERATURE RANGE:
 -30°C to 120°C.

SFR (cast iron) wheels are not suitable where substantial shock loads are to be withstood, and they have a limited service life in comparison with the equivalent SSFR wheel.

When shock loadings are to be withstood by either the SFR or SSFR ranges the 'maximum load rating' should be reduced by multiplying by a shock loading factor of 0.65.

SFR CAST-IRON SERIES

PART NUMBER:
SFR133/35/BJA

Maximum load rating:
600Kg

See pages 23-26 for load factors
Approximate weight: 5Kg

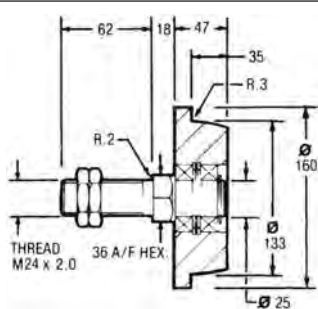

PART NUMBER:
SFR175/35/BJA

Maximum load rating:
800Kg

See pages 23-26 for load factors
Approximate weight: 8Kg

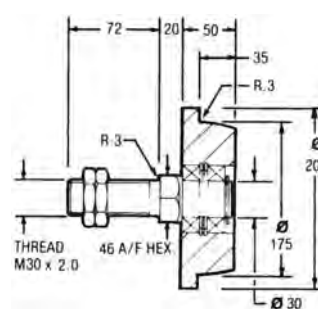

SSFR STEEL SERIES

PART NUMBER:
SSFR55/25/BJA

Maximum load rating:
160Kg

See pages 23-26 for load factors
Approximate weight: 1Kg

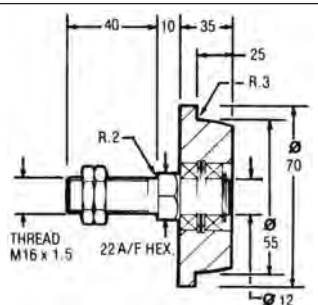

PART NUMBER:
SSFR85/25/BJA

Maximum load rating:
370Kg

See pages 23-26 for load factors
Approximate weight: 2.5Kg

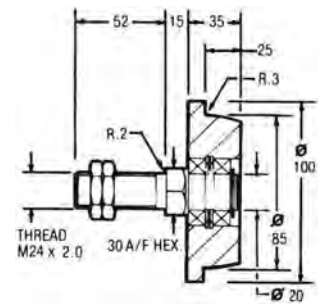

PART NUMBER:
SSFR105/25/BJA

Maximum load rating:
700Kg

See pages 23-26 for load factors
Approximate weight: 4kg

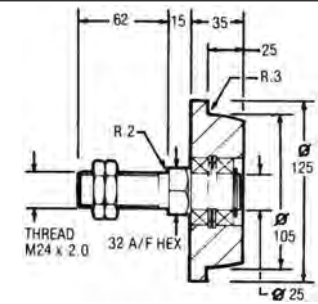

PART NUMBER:
SSFR133/35/BJA

Maximum load rating:
1000Kg

See pages 23-26 for load factors
Approximate weight: 7Kg

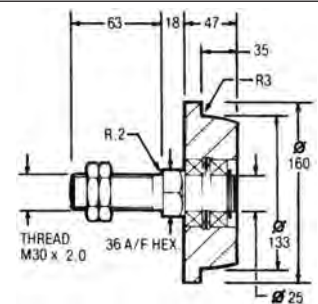

PART NUMBER:
SSFR175/35/BJA

Maximum load rating:
1500Kg

See pages 23-26 for load factors
Approximate weight: 11.5Kg

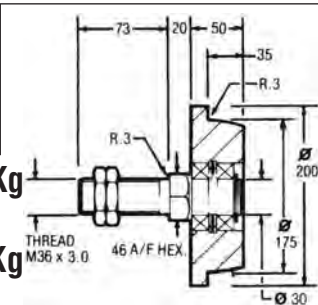

SINGLE FLANGED 'I' BEAM & CHANNEL

RAIL SECTION



RAIL

- For correct selection of rail-clips, please contact Brauer Sales department.
- Conventional rail section can be 'fish-plated' or welded. Bridge & Crane rail, welded, butted or 45° taper (joined) then clipped.
- Gauge tolerance is not set to a standard but $\pm 3.00\text{mm}$ should be considered.
- Do not drill foot of rail as it weakens the section: use the correct rail-clips specified by Brauer.
- CES2:1987; is the British steel rail standard.
- Gauge means distance between (G) "Gauge"

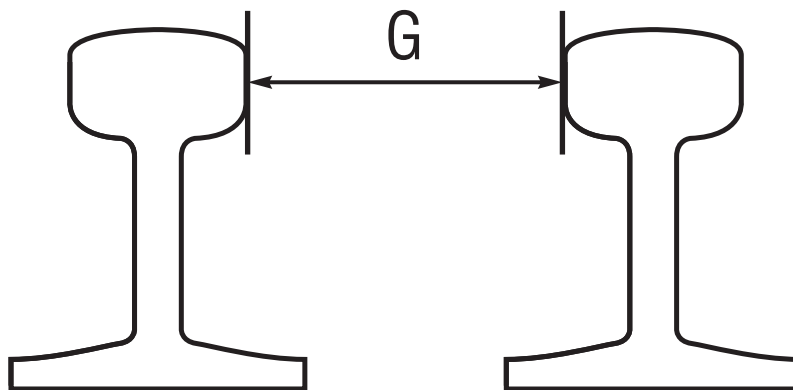

- Clips should normally be set approximately 60-70 cm pitch as a recommendation

Rail sections are now available to offer complete solutions for customer requirements. Advice on fixing components and matching rail to wheels are available on request.



Section	Weight kg/m	A Head mm	B Height mm	C Base mm	D Web mm	Type	Shape
X BSC 13	13.306	36	48	92	0	BRIDGE	
X BSC 16	16.029	44.5	54	108	0	BRIDGE	
X BSC 20	19.861	50	55.5	127	0	BRIDGE	
X BSC 50	50.175	58.5	76	165	0	BRIDGE	
A45	22.1	45	55	125	24	CRANE	
A55	31.8	55	65	150	31	CRANE	
A65	43.1	65	75	175	38	CRANE	
A75	56.2	75	85	200	45	CRANE	
A100	74.3	100	95	200	60	CRANE	
A120	100	120	105	220	72	CRANE	
X BSC 56	56.806	76	101.5	171	35	CRANE	
X BSC 89	89.81	102	114	178	51	CRANE	
X BSC101	100.383	100	155	165	45	CRANE	

NOTE: Items with **X** are not manufactured by steel mills now. Items in **bold** are at time of printing still currently manufactured.



Section	Weight kg/m	A Head mm	B Height mm	C Base mm	D Web mm	Type	Shape
X BS20 'M'	9.881	30.96	65.09	55.56	6.76	FLAT BOTTOM	
X BS30 'M'	14.785	38.10	75.41	69.85	9.13	FLAT BOTTOM	
BS35 'M'	17.387	42.86	80.96	76.20	9.13	FLAT BOTTOM	
X BSC 40	20.09	45.64	88.10	80.57	12.3	FLAT BOTTOM	
ASCE 40	20.09	42.60	88.9	88.9	9.9	MINE	
X BS50 'O'	24.833	52.39	100.01	100.01	10.32	FLAT BOTTOM	
BS60 'A'	30.618	57.15	114.3	109.54	11.11	FLAT	
BS80 'A'	39.761	63.5	133.35	117.47	13.1	L/MAIN	
X BS80 'O'	39.781	63.5	127	127	13.59	L/MAIN	
ASCE 80	39.86	68.5	127	127	13.89	MAIN	
BS113A (56 E1)	56.398	69.85	158.75	139.70	20	MAIN	
S41-R10 (41 E1)	41.38	67	138	125	12	MAIN	
UIC54 (54 E1)	54.43	70	159	140	16	MAIN	
UIC60 (41 E1)	60.34	72	172	150	16.5	MAIN	
S10	10	70	58	32	6	EUROPEAN FLAT BOTTOM	
S14	14	80	70	38	9	EUROPEAN FLAT BOTTOM	
S30	30.03	108	108	60.30	12.3	EUROPEAN FLAT BOTTOM	

NOTE: Items with X are not manufactured by steel mills now. Items in bold are at time of printing still currently manufactured.



Untyred wheels can carry high loads with low rolling resistance when used on a hard surface such as flat steel. On softer surfaces, such as concrete or tarmac, the surface is likely to be worn or indented by the use of an untyred wheel. Untyred wheels are noisier in operation than tyred wheels, but noise is unlikely to be a problem at walking speeds.

MATERIAL: Cast iron to BS1452: 1977: Grade 200.

OPERATING TEMPERATURE RANGE:

- Plain bored or keywayed wheels – 30°C to 250°C
- Ball or taper roller bearinged wheels – 30°C to 120°C

Alternative bore/bearing diameters and alternative bearing types (i.e. bronze bushes, self-lubricating bushes, roller bearings, spherical roller bearings, etc.) are available to order – see page 26-27.

For wheels of larger diameter or greater load capacity see the CFT series (pages 48 & 49) and SFT series (pages 45-47).

For technical information covering load factors, inertial and rolling resistance, coefficients of friction between wheel and track, and keyway dimensions, see “Design Data” Index on page 20.

Drawings show grease nipple but standard wheels do not come with grease nipple unless specifically requested.

CAST IRON UNTYRED

WHEEL TYPE:
C75/40

See table for full part number

Maximum load rating:
400Kg

See page 23-26 for load factors

Approximate weight: 0.75Kg

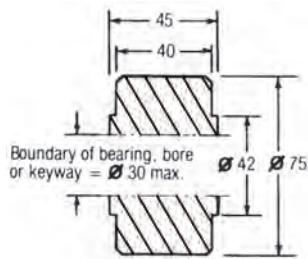

Wheels fitted with ball journals are pre-lubricated, double shielded

WHEEL TYPE:
C100/30

See table for full part number

Maximum load rating:
400Kg

See page 23-26 for load factors

Approximate weight: 1Kg

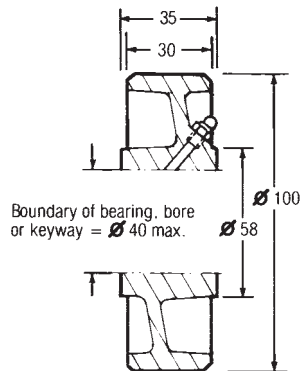

FULL PART NUMBER FOR ORDERING

Axle Ø	Plain Bore	Plain Bore Keywayed	Ball Bearing	Taper Roller Bearing
METRIC AXLE Ø				
12	C75/40/PBM 12	C75/40/KM 12	C75/40/BJM 12	
20	C75/40/PBM 20	C75/40/KM 20		
25	C75/40/PBM 25	C75/40/KM 25		

METRIC AXLE Ø				
20	C100/30/PBM 20	C100/30/KM 20	C100/30/BJM 20	
25	C100/30/PBM 25	C100/30/KM 25		
30	C100/30/PBM 30	C100/30/KM 30		

Cast Iron Untyred Wheels



WHEEL TYPE: C100/45

See table for full part number

Maximum load rating:
600Kg

See page 23-26 for load factors

Approximate weight: **1.5Kg**

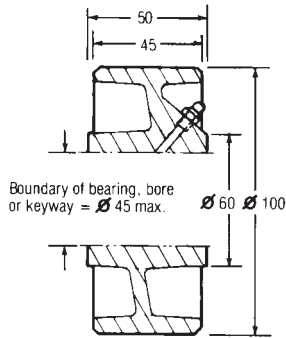

FULL PART NUMBER FOR ORDERING

Axle Ø	Plain Bore	Plain Bore Keywayed	Ball Bearing	Taper Roller Bearing
METRIC AXLE Ø				
25	C100/45/PBM 25	C100/45/KM 25	C100/45/BJM 25	
30	C100/45/PBM 30	C100/45/KM 30		

WHEEL TYPE: C125/35

See table for full part number

Maximum load rating:
550Kg

See page 23-26 for load factors

Approximate weight: **1.5Kg**

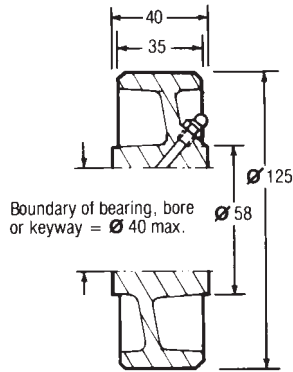

METRIC AXLE Ø

20	C125/35/PBM 20	C125/35/KM 20	C125/35/BJM 20	
25	C125/35/PBM 25	C125/35/KM 25		
30	C125/35/PBM 30	C125/35/KM 30		

WHEEL TYPE: C125/50

See table for full part number

Maximum load rating:
800Kg

See page 23-26 for load factors

Approximate weight: **2.5Kg**

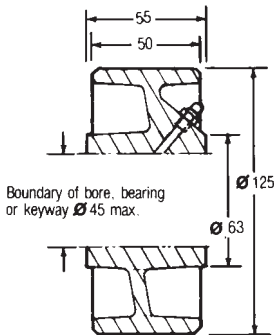

METRIC AXLE Ø

25	C125/50/PBM 25	C125/50/KM 25	C125/50/BJM 25	
30	C125/50/PBM 30	C125/50/KM 30		

WHEEL TYPE: C150/40

See table for full part number

Maximum load rating:
800Kg

See page 23-26 for load factors

Approximate weight: **2.5Kg**

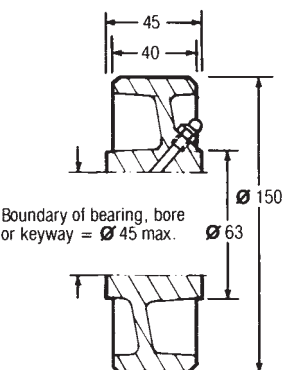

METRIC AXLE Ø

25	C150/40/PBM 25	C150/40/KM 25	C150/40/BJM 25	
30	C150/40/PBM 30	C150/40/KM 30		

CAST IRON UNTYRED

WHEEL TYPE:
C150/60
See table for full part number

Maximum load rating:
1200Kg
See page 23-26 for load factors
Approximate weight: 3.5Kg

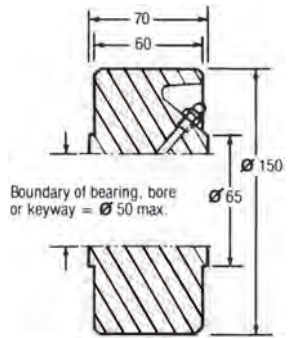

FULL PART NUMBER FOR ORDERING				
Axle Ø	Plain Bore	Plain Bore Keywayed	Ball Bearing	Taper Roller Bearing
METRIC AXLE Ø				
25	C150/60/PBM 25	C150/60/KM 25	C150/60/BJM 25	
30	C150/60/PBM 30	C150/60/KM 30		
35	C150/60/PBM 35	C150/60/KM 35		

LOAD LIMITED BY BEARINGS TO: (1) 1140Kg

WHEEL TYPE:
C200/45
See table for full part number

Maximum load rating:
1200Kg
See page 23-26 for load factors
Approximate weight: 4.5Kg

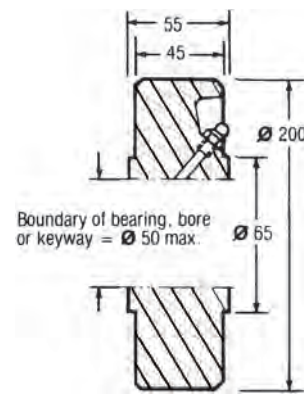

METRIC AXLE Ø				
25	C200/45/PBM 25	C200/45/KM 25	C200/45/BJM 25	
30	C200/45/PBM 30	C200/45/KM 30		
35	C200/45/PBM 35	C200/45/KM 35		

LOAD LIMITED BY BEARINGS TO: (1) 1140Kg

WHEEL TYPE:
C200/70
See table for full part number

Maximum load rating:
1800Kg
See page 23-26 for load factors
Approximate weight: 8Kg

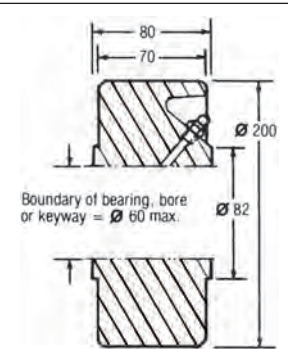

METRIC AXLE Ø				
30	C200/70/PBM 30	C200/70/KM 30	C200/70/BJM 30	
35	C200/70/PBM 35	C200/70/KM 35		
40	C200/70/PBM 40	C200/70/KM 40		
50	C200/70/PBM 50	C200/70/KM 50		

WHEEL TYPE:
C250/50
See table for full part number

Maximum load rating:
1600Kg
See page 23-26 for load factors
Approximate weight: 9Kg

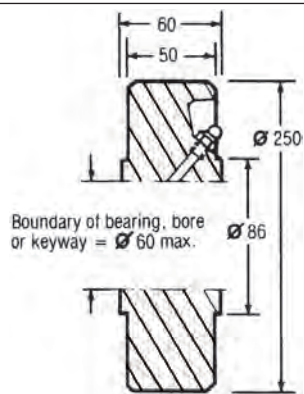

METRIC AXLE Ø				
30	C250/50/PBM 30	C250/50/KM 30	C250/50/BJM 30	
35	C250/50/PBM 35	C250/50/KM 35		
40	C250/50/PBM 40	C250/50/KM 40		
50	C250/50/PBM 50	C250/50/KM 50		

Cast Iron Untyred Wheels



WHEEL TYPE: C250/75

See table for full part number

Maximum load rating:
2500Kg

See page 23-26 for load factors

Approximate weight: **14Kg**

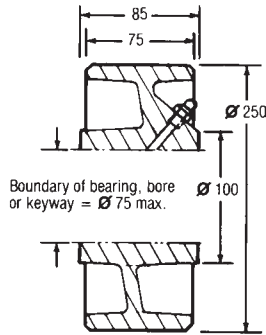

FULL PART NUMBER FOR ORDERING

Axle Ø	Plain Bore	Plain Bore Keywayed	Ball Bearing	Taper Roller Bearing
METRIC AXLE Ø				
30	C250/75/PBM 30	C250/75/KM 30	(1) C250/75/BJM 30	
35	C250/75/PBM 35	C250/75/KM 35	C250/75/BJM 35	
40	C250/75/PBM 40	C250/75/KM 40		
50	C250/75/PBM 50	C250/75/KM 50		

LOAD LIMITED BY BEARINGS TO: (1) 2040Kg

WHEEL TYPE: C250/100

See table for full part number

Maximum load rating:
3300Kg

See page 23-26 for load factors

Approximate weight: **17Kg**

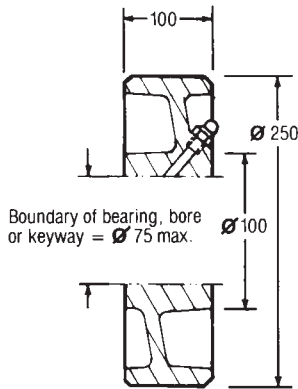

METRIC AXLE Ø				
35	C250/100/PBM 35	C250/100/KM 35	(1) C250/100/BJM 35	
40	C250/100/PBM 40	C250/100/KM 40	C250/100/BJM 40	
50	C250/100/PBM 50	C250/100/KM 50		
60	C250/100/PBM 60	C250/100/KM 60		

LOAD LIMITED BY BEARINGS TO: (1) 2800Kg

WHEEL TYPE: C350/100

See table for full part number

Maximum load rating:
4600Kg

See page 23-26 for load factors

Approximate weight: **36Kg**

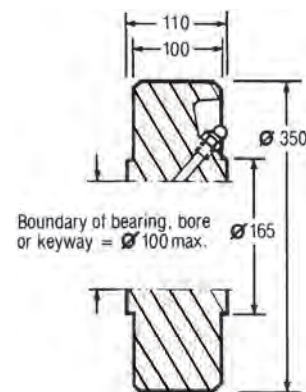

METRIC AXLE Ø				
35	C350/100/PBM 35	C350/100/KM 35	(1) C350/100/BJM 35	
40	C350/100/PBM 40	C350/100/KM 40	(2) C350/100/BJM 40	
50	C350/100/PBM 50	C350/100/KM 50	C350/100/BJM 50	
60	C350/100/PBM 60	C350/100/KM 60		

LOAD LIMITED BY BEARINGS TO: (1) 2800Kg (2) 3384Kg

WHEEL TYPE: C350/125

See table for full part number

Maximum load rating:
5700Kg

See page 23-26 for load factors

Approximate weight: **44Kg**

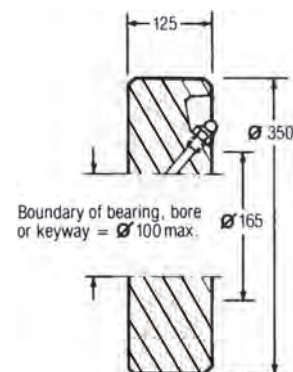

METRIC AXLE Ø				
40	C350/125/PBM 40	C350/125/KM 40	(1) C350/125/BJM 40	
50	C350/125/PBM 50	C350/125/KM 50	C350/125/BJM 50	
60	C350/125/PBM 60	C350/125/KM 60		

LOAD LIMITED BY BEARINGS TO: (1) 3384Kg

CAST IRON UNTYRED



Brauer HEAVITHANE™ Polyurethane is resilient, durable material, resistant to abrasion and to many common chemicals. Polyurethane tyred wheels are capable of carrying heavy loads and of transmitting driving forces.

MATERIAL: Wheel centre – cast iron to BS1452: 1977: Grade 200 or steel to BS970: Part 1: 1983: 080M40.
Tyre – Polyester based polymer of 92± 3° A Shore hardness.

OPERATING TEMPERATURE RANGE:
-20°C to +60°C (115°C for limited use)

PLEASE SPECIFY IF OPERATING IN HIGH HUMIDITY.

Anti-hydrolysis polyurethane is recommended for use in an operating environment of high humidity.

Polyurethane to the above hardness used on these wheels is Vulkollan, a high quality material that provides superior performance in most applications.

Should the mechanical properties of standard Vulkollan be inappropriate for the application, alternative grades of Polyurethane can be produced to meet the requirements. Polyurethane can be bonded onto most metal centres including aluminium, titanium, stainless steel and various ferrous and non-ferrous alloys.

The 'maximum load rating' given for each wheel is for operation under ideal conditions. Load factors must be applied according to the anticipated working conditions – see 'Design Data' para. 5.1.

For wheels of larger diameter or greater load capacity see the PH series on pages 78-81. Alternative bore/bearing diameters and alternative bearing types (i.e. bronze bushes, self-lubricating bushes, roller bearings, spherical roller bearings, etc.) are available to order – see page 26-27.

For technical information covering load factors, chemical resistance, inertial and rolling resistance, coefficients of friction between wheel and surface, and keyway dimensions, see "Design Data" Index on page 20.

Drawings show grease nipple but standard wheels do not come with grease nipple unless specifically requested.

Tyres can be produced with crown/dome treads to suit specific applications.

ALLOWABLE LOADS @ 6KPH

WHEEL TYPE:

H75/35

See table for full part number

Maximum load rating:
300Kg

See page 22 for load factors

Approximate weight: 0.5Kg

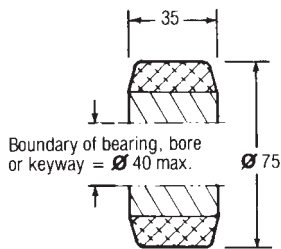

Wheels fitted with ball journals are pre-lubricated, double shielded

WHEEL TYPE:

H85/75

See table for full part number

Maximum load rating:
700Kg

See page 22 for load factors

Approximate weight: 0.6Kg

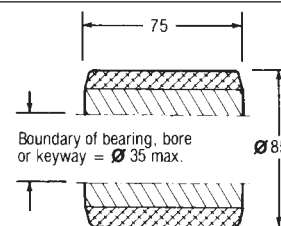

Wheels fitted with ball journals are pre-lubricated, double shielded

FULL PART NUMBER FOR ORDERING

Axle Ø	Plain Bore	Plain Bore Keywayed	Ball Bearing	Taper Roller Bearing
METRIC AXLE Ø				
12	H75/35/PBM 12	H75/35/KM 12	H75/35/BJM 12	
20	H75/35/PBM 20	H75/35/KM 20	H75/35/BJM 20	
25	H75/35/PBM 25	H75/35/KM 25		
30	H75/35/PBM 30	H75/35/KM 30		

METRIC AXLE Ø				
20	N/A		H85/75/BJM 20	

Polyurethane Tyred Wheels



Drawings show grease nipple but standard wheels do not come with grease nipple unless specifically requested.

FULL PART NUMBER FOR ORDERING

Axle Ø	Plain Bore	Plain Bore Keywayed	Ball Bearing	Taper Roller Bearing
METRIC AXLE Ø				
12	H100/40/PBM 12	H100/40/KM 12	H100/40/BJM 12	
20	H100/40/PBM 20	H100/40/KM 20	H100/40/BJM 20	
25	H100/40/PBM 25	H100/40/KM 25	H100/40/BJM 25	
30	H100/40/PBM 30	H100/40/KM 30		
35	H100/40/PBM 35	H100/40/KM 35		

WHEEL TYPE: H100/40

See table for full part number

Maximum load rating:
450Kg

See page 22 for load factors

Approximate weight: **1.5Kg**

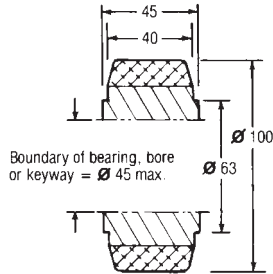

Wheels fitted with ball journals are pre-lubricated, double shielded

WHEEL TYPE: H100/100

See table for full part number

Maximum load rating:
1100Kg

See page 22 for load factors

Approximate weight: **5Kg**

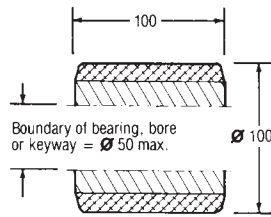

Wheels fitted with ball journals are pre-lubricated, double shielded

METRIC AXLE Ø

20	N/A		H100/100/BJM 20	H100/100/TBM 20
25	N/A		H100/100/BJM 25	H100/100/TBM 25
30	N/A		H100/100/BJM 30	H100/100/TBM 30
35	N/A	H100/100/KM 35		

LOAD LIMITED BY BEARINGS TO: (1) 900Kg

WHEEL TYPE: H125/30

See table for full part number

Maximum load rating:
400Kg

See page 22 for load factors

Approximate weight: **1.5Kg**

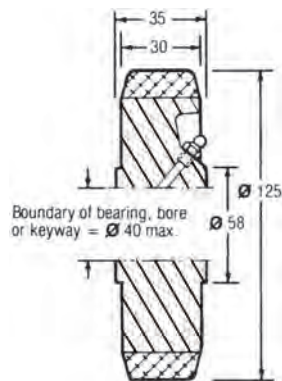

METRIC AXLE Ø

20	H125/30/PBM 20	H125/30/KM 20	H125/30/BJM 20	
25	H125/30/PBM 25	H125/30/KM 25	H125/30/BJM 25	
30	H125/30/PBM 30	H125/30/KM 30		
35	H125/30/PBM 35	H125/30/KM 35		

WHEEL TYPE: H125/45

See table for full part number

Maximum load rating:
600Kg

See page 22 for load factors

Approximate weight: **2Kg**

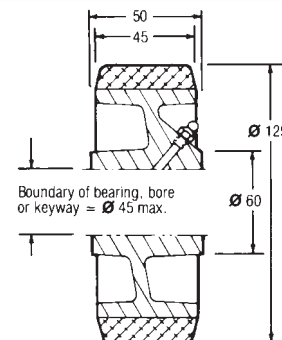

METRIC AXLE Ø

25	H125/45/PBM 25	H125/45/KM 25	H125/45/BJM 25	
30	H125/45/PBM 30	H125/45/KM 30		
35	H125/45/PBM 35	H125/45/KM 35		

POLYURETHANE TYRED

WHEEL TYPE:
H150/35
See table for full part number

Maximum load rating:
600Kg
See page 22 for load factors
Approximate weight: 2Kg

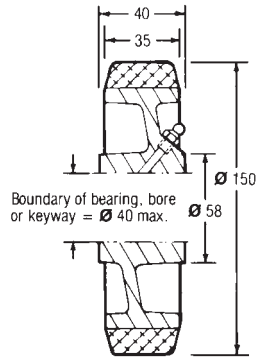

FULL PART NUMBER FOR ORDERING				
Axle Ø	Plain Bore	Plain Bore Keywayed	Ball Bearing	Taper Roller Bearing
METRIC AXLE Ø				
20	H150/35/PBM 20	H150/35/KM 20	H150/35/BJM 20	
25	H150/35/PBM 25	H150/35/KM 25	H150/35/BJM 25	
30	H150/35/PBM 30	H150/35/KM 30		

WHEEL TYPE:
H150/50
See table for full part number

Maximum load rating:
900Kg
See page 22 for load factors
Approximate weight: 3Kg

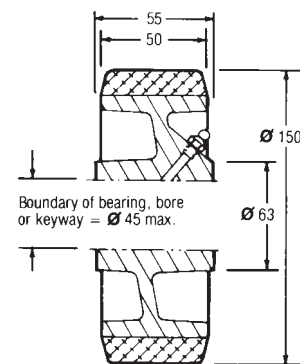

METRIC AXLE Ø				
25	H150/50/PBM 25	H150/50/KM 25	H150/50/BJM 25	H150/50/TBM 25
30	H150/50/PBM 30	H150/50/KM 30		
35	H150/50/PBM 35	H150/50/KM 35		

WHEEL TYPE:
H150/150
See table for full part number

Maximum load rating:
2300Kg
See page 22 for load factors
Approximate weight: 7Kg

Wheels fitted with ball journals are pre-lubricated, double shielded

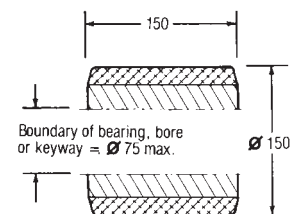

METRIC AXLE Ø				
25	N/A		H150/150/BJM 25 ⁽¹⁾	H150/150/TBM 25
30	N/A		H150/150/BJM 30 ⁽²⁾	H150/150/TBM 30
35	N/A	H150/150/KM 35	H150/150/BJM 35	H150/150/TBM 35

LOAD LIMITED BY BEARINGS TO: (1) 1140kg (2) 2040Kg

WHEEL TYPE:
H200/40
See table for full part number

Maximum load rating:
900Kg
See page 22 for load factors
Approximate weight: 4Kg

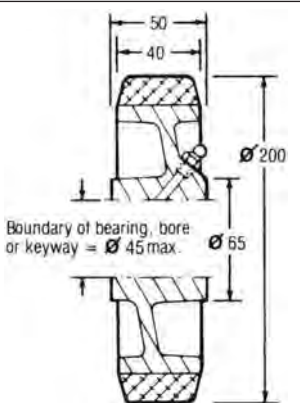

METRIC AXLE Ø				
25	H200/40/PBM 25	H200/40/KM 25	H200/40/BJM 25	H200/40/TBM 25
30	H200/40/PBM 30	H200/40/KM 30	H200/40/BJM 30	
35	H200/40/PBM 35	H200/40/KM 35		
40	H200/40/PBM 40	H200/40/KM 40		

Polyurethane Tyred Wheels



WHEEL TYPE:
H200/60
See table for full part number

Maximum load rating:
1400Kg
See page 22 for load factors

Approximate weight: 7Kg

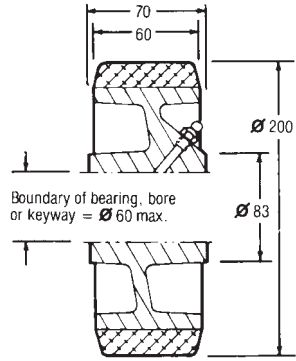

FULL PART NUMBER FOR ORDERING				
Axle Ø	Plain Bore	Plain Bore Keywayed	Ball Bearing	Taper Roller Bearing
METRIC AXLE Ø				
30	H200/60/PBM 30	H200/60/KM 30	H200/60/BJM 30	H200/60/TBM 30
35	H200/60/PBM 35	H200/60/KM 35		H200/60/TBM 35
40	H200/60/PBM 40	H200/60/KM 40		

WHEEL TYPE:
H200/75
See table for full part number

Maximum load rating:
1750Kg
See page 22 for load factors

Approximate weight: 14.4Kg

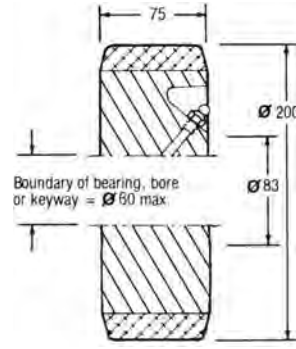

METRIC AXLE Ø				
25		H200/75/KM 25	H200/75/BJM 25	H200/75/TBM 25
30		H200/75/KM 30	H200/75/BJM 30	H200/75/TBM 30
35		H200/75/KM 35		
40		H200/75/KM 40		

LOAD LIMITED BY BEARINGS TO: (1) 1140Kg

WHEEL TYPE:
H250/45
See table for full part number

Maximum load rating:
1300Kg
See page 22 for load factors

Approximate weight: 7Kg

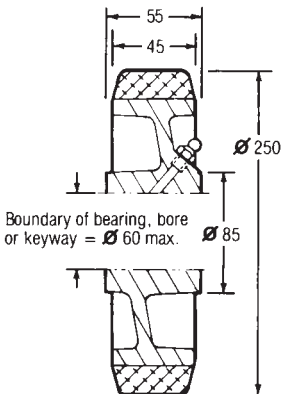

METRIC AXLE Ø				
30	H250/45/PBM 30	H250/45/KM 30	H250/45/BJM 30	H250/45/TBM 30
35	H250/45/PBM 35	H250/45/KM 35		H250/45/TBM 35
40	H250/45/PBM 40	H250/45/KM 40		

WHEEL TYPE:
H250/70
See table for full part number

Maximum load rating:
2000Kg
See page 22 for load factors

Approximate weight: 12Kg

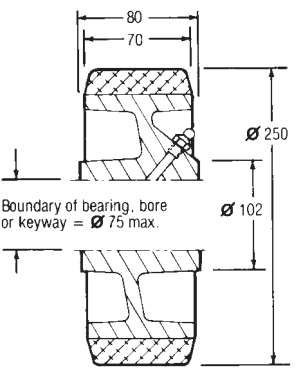

METRIC AXLE Ø				
30	H250/70/PBM 30	H250/70/KM 30	H250/70/BJM 30	H250/70/TBM 30
35	H250/70/PBM 35	H250/70/KM 35	H250/70/BJM 35	H250/70/TBM 35
40	H250/70/PBM 40	H250/70/KM 40		
50	H250/70/PBM 50	H250/70/KM 50		

POLYURETHANE TYRED

WHEEL TYPE:
H250/97.5

See table for full part number

Maximum load rating:

2700Kg

See page 22 for load factors

Approximate weight: 19.5Kg

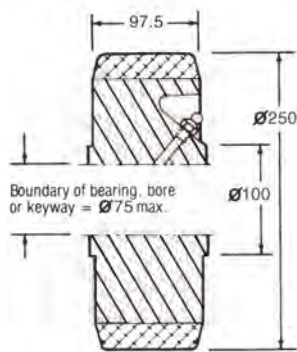

Wheels fitted with ball journals are pre-lubricated, double shielded

FULL PART NUMBER FOR ORDERING

Axle Ø	Plain Bore	Plain Bore Keywayed	Ball Bearing	Taper Roller Bearing
METRIC AXLE Ø				
40	H250/97.5/PBM 40	H250/97.5/KM 40	H250/97.5/BJM 40	H250/97.5/TBM 40
50	H250/97.5/PBM 50	H250/97.5/KM 50	H250/97.5/BJM 50	H250/97.5/TBM 50

WHEEL TYPE:
H300/50

See table for full part number

Maximum load rating:

1500Kg

See page 22 for load factors

Approximate weight: 10Kg

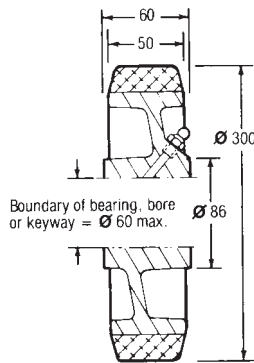

METRIC AXLE Ø				
30	H300/50/PBM 30	H300/50/KM 30	H300/50/BJM 30	H300/50/TBM 30
35	H300/50/PBM 35	H300/50/KM 35	H300/50/BJM 35	H300/50/TBM 35
40	H300/50/PBM 40	H300/50/KM 40		
50	H300/50/PBM 50	H300/50/KM 50		

WHEEL TYPE:
H300/75

See table for full part number

Maximum load rating:

2300Kg

See page 22 for load factors

Approximate weight: 16Kg

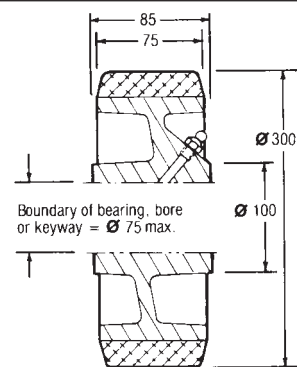

METRIC AXLE Ø				
35	H300/75/PBM 35	H300/75/KM 35	H300/75/BJM 35	H300/75/TBM 35
40	H300/75/PBM 40	H300/75/KM 40	H300/75/BJM 40	H300/75/TBM 40
50	H300/75/PBM 50	H300/75/KM 50		
60	H300/75/PBM 60	H300/75/KM 60		

WHEEL TYPE:
H300/100

See table for full part number

Maximum load rating:

3100Kg

See page 22 for load factors

Approximate weight: 18Kg

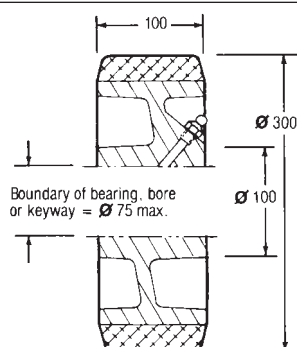

METRIC AXLE Ø				
40	H300/100/PBM 40	H300/100/KM 40	H300/100/BJM 40	H300/100/TBM 40
50	H300/100/PBM 50	H300/100/KM 50	H300/100/BJM 50	H300/100/TBM 50
60	H300/100/PBM 60	H300/100/KM 60		

Polyurethane Tyred Wheels



WHEEL TYPE:
H350/100

See table for full part number

Maximum load rating:

3600Kg

See page 22 for load factors

Approximate weight: **52Kg**

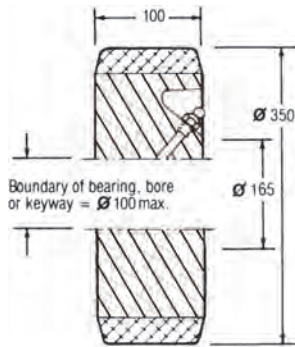

FULL PART NUMBER FOR ORDERING

Axle Ø	Plain Bore	Plain Bore Keywayed	Ball Bearing	Taper Roller Bearing
METRIC AXLE Ø				
40		H350/100/KM 40	H350/100/BJM 40	H350/100/TBM 40
50		H350/100/KM 50	H350/100/BJM 50	H350/100/TBM 50
60		H350/100/KM 60	H350/100/BJM 60	H350/100/TBM 60

LOAD LIMITED BY BEARINGS TO: (1) 3384Kg

WHEEL TYPE:
H400/100

See table for full part number

Maximum load rating:

4200Kg

See page 22 for load factors

Approximate weight: **65Kg**

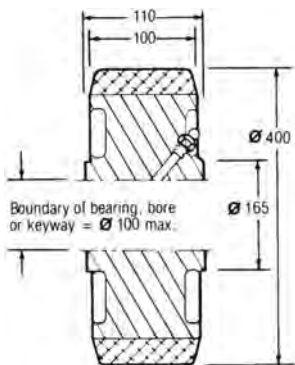

METRIC AXLE Ø

50	H400/100/PBM 50	H400/100/KM 50	H400/100/BJM 50	H400/100/TBM 50
60	H400/100/PBM 60	H400/100/KM 60	H400/100/BJM 60	H400/100/TBM 60
75	H400/100/PBM 75	H400/100/KM 75	H400/100/BJM 75	H400/100/TBM 75

WHEEL TYPE:
H400/125

See table for full part number

Maximum load rating:

5200Kg

See page 22 for load factors

Approximate weight: **80Kg**

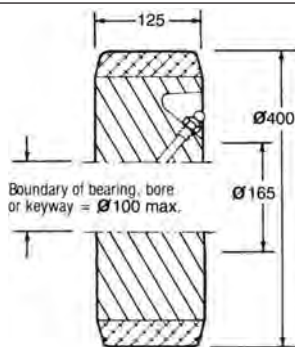

METRIC AXLE Ø

50	H400/125/PBM 50	H400/125/KM 50	H400/125/BJM 50	H400/125/TBM 50
60	H400/125/PBM 60	H400/125/KM 60	H400/125/BJM 60	H400/125/TBM 60
75	H400/125/PBM 75	H400/125/KM 75	H400/125/BJM 75	H400/125/TBM 75

WHEEL TYPE:
H460/75

See table for full part number

Maximum load rating:

3500Kg

See page 22 for load factors

Approximate weight: **80Kg**

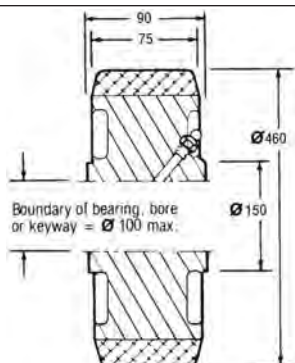

METRIC AXLE Ø

50	H460/75/PBM 50	H460/75/KM 50	H460/75/BJM 50	
60	H460/75/PBM 60	H460/75/KM 60	H460/75/BJM 60	H460/75/TBM 60
75			H460/75/BJM 75	H460/75/TBM 75

POLYURETHANE TYRED

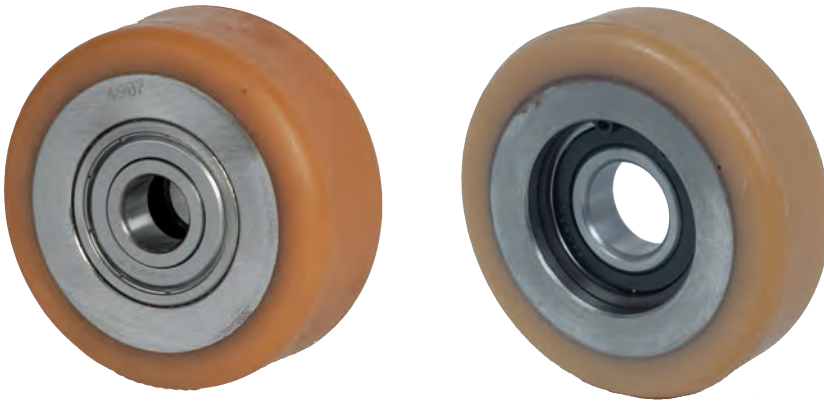

Temperature range of operation -40° to +85°C. The polyurethane is non-marking, with high resistance to axial loading, and runs quietly. Used in conveyor applications, systems of transporting products along material handling systems or in areas of support for hanging structures or components, as found in;

- escalators
- sorting
- overhead conveyors
- conveyors for letter & mail
- baggage handling airport equipment

Higher load capacity than Vulkopan, due to the chemical bonding and therefore far more resistant to axial forces. 92° shore hardness guarantees higher levels of elasticity and damping & improved traction. Finally, Vulkollan unlike Vulkopan can be machined after setting for specific tolerancing.

NAME		VULKOLLAN 90	
ABBREVIATION		VK90	
COLOUR		NATURAL	
HARDNESS	SHORE A/D	92/37	DIN 53505
STRESS AT 100% STRAIN	MPa	8.6	DIN 53504
STRESS AT 300% STRAIN	MPa	18.8	DIN 53504
TENSILE STRENGTH	MPa	42	DIN 53504
ELONGATION AT BREAK	%	650	DIN 53504
TEAR PROPAGATION RESISTANCE	kN/m	58	DIN 53515
REBOUND	%	55	DIN 53512
ABRASION RESISTANCE	mm ³	42	DIN 53516
DENSITY	g/cm ³	1.26	DIN 53479
COMPRESSION SET %	70 h / 23°C 70 h / 73.5°F	12	DIN 53517
	24 h / 70°C 24 h / 158°F	20	

Vulkollan 90 Guide Rollers



'VK' GUIDE ROLLER TECHNICAL INFORMATION

Polyurethane 92° Shore A: Hardness

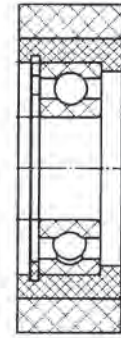
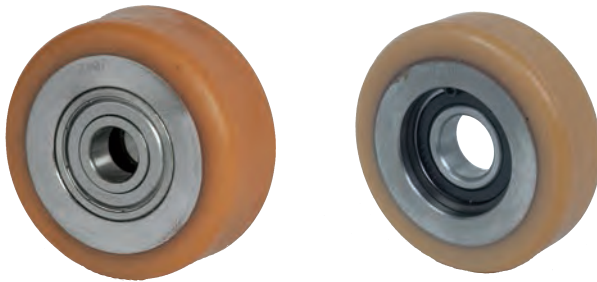

VK RK 035 011 008 S	35	11	8	608-2RS	50	
VK RK 040 012 010 Z	40	12	10	6000-ZZ	60	
VK RK 040 015 010 S	40	15	10	6000-2RS	60	
VK RK 040 015 010 Z	40	15	10	6000-ZZ	60	
VK RK 040 016 012 Z	40	16	12	6001-ZZ	60	
VK RK 040 025 010 Z	40	25	10	6000-ZZ	60	
VK RK 045 015 015	45	15	15	61902-ZZ	70	
VK RK 045 038 010 S	45	38	10	6200-2RS	70	
VK RK 050 015 010 S	50	15	10	6000-2RS	85	
VK RK 050 015 012 SA	50	15	12	6001-2RS	85	
VK RK 050 015 012 Z	50	15	12	6001-ZZ	85	
VK RK 050 015 015 Z	50	15	15	6001-ZZ	85	
VK RK 050 018 012 Z	50	18	12	6201-ZZ	95	
VK RK 050 018 017 S	50	18	17	6003-2RS	95	
VK RK 050 018 020 Z	50	18	20	61804-ZZ	95	
VK RK 050 020 010 SB	50	20	10	6200-2RS	100	
VK RK 050 020 012 S	50	20	12	6201-2RS	100	
VK RK 050 020 012 ZB	50	20	12	6201-ZZ	100	
VK RK 050 020 017 Z	50	20	17	6003-ZZ	100	
VK RK 050 025 010 Z	50	25	10	6200-ZZ	105	
VK RK 050 025 012 S	50	25	12	6201-2RS	105	
VK RK 055 020 012 S	55	20	12	6201-2RS	105	
VK RK 055 020 015 S	55	20	15	6002-2RS	105	
VK RK 060 014 010 ZB	60	14	10	6200-ZZ	110	
VK RK 060 016 015 ZB	60	16	15	6202-ZZ	110	
VK RK 060 017 012 SB	60	17	12	6201-2RS	110	
VK RK 060 018 017 SA	60	18	17	6003-2RS	110	
VK RK 060 018 017 ZA	60	18	17	6003-ZZ	110	
VK RK 060 020 017 SA	60	20	17	6003-2RS	120	
VK RK 060 020 017 SB	60	20	17	6203-2RS	120	
VK RK 060 020 017 SK	60	20	17	6203-2RS	120	
VK RK 060 020 017 ZB	60	20	17	6203-ZZ	120	
VK RK 060 020 020 SA	60	20	20	6004-2RS	120	
VK RK 060 020 017 ZA	60	20	20	6004-ZZ	120	
VK RK 060 025 015 ZD	60	25	15	6002-ZZ	125	
VK RK 060 025 017 Z	60	25	17	6003-ZZ	125	
VK RK 060 025 020	60	25	20	6004-ZZ	125	

VK RK 065 016 020 S	65	16	20	6004-2RS	125	
VK RK 070 020 020 SB	70	20	20	6204-2RS	130	
VK RK 070 020 020 ZB	70	20	20	6204-ZZ	130	
VK RK 070 020 020 ZC	70	25	17	6303-ZZ	150	
VK RK 070 025 020 S	70	25	20	6204-2RS	150	
VK RK 070 025 020 Z	70	25	20	6204-ZZ	150	
VK RK 070 025 020 ZC	70	25	20	6304-ZZ	150	
VK RK 070 025 025 S	70	25	25	6205-2RS	150	
VK RK 070 025 025 Z	70	25	25	6005-ZZ	150	
VK RK 080 020 017 Z	80	20	17	6303-ZZ	150	
VK RK 080 020 020 Z	80	20	20	6304-ZZ	150	
VK RK 080 020 025 ZB	80	20	25	6205-ZZ	150	
VK RK 080 025 020 SA	80	25	20	6004-2RS	170	
VK RK 080 025 025 S	80	25	25	6205-2RS	170	
VK RK 080 025 025 Z	80	25	25	6205-ZZ	170	
VK RK 080 030 020 S	80	30	20	6204-2RS	180	
VK RK 080 030 020 Z	80	30	20	6204-ZZ	180	
VK RK 090 020 025 SB	90	20	25	6205-2RS	170	
VK RK 090 025 025 Z	90	25	25	6005-ZZ	190	
VK RK 090 035 020 Z	90	35	20	6304-ZZ	200	
VK RK 100 020 025 S	100	20	25	6205-2RS	190	
VK RK 100 020 025 ZB	100	20	25	6205-ZZ	190	
VK RK 100 025 020 Z	100	20	20	6204-ZZ	210	
VK RK 100 025 025 ZB	100	25	25	6205-ZZ	210	
VK RK 100 028 020 S	100	28	20	6204-2RS	215	
VK RK 100 030 020 ZC	100	30	20	6304-ZZ	220	
VK RK 100 030 025 S	100	30	25	6205-2RS	220	
VK RK 100 030 025 ZB	100	30	25	6205-ZZ	220	
VK RK 120 025 025 Z	120	25	25	6205-ZZ	250	
VK RK 120 030 030 S	120	30	30	6206-2RS	260	
VK RK 125 025 025 Z	125	25	25	6205-ZZ	260	
VK RK 125 030 025 S	125	30	25	6205-2RS	260	
VK RK 125 030 025 ZB	125	30	25	6205-ZZ	260	
VK RK 125 030 030 R	125	30	30	6206-2RS	260	
VK RK 125 030 030 Z	125	30	30	6306-ZZ	260	

VULKOLLAN 90 GUIDE ROLLERS



Temperature range of operation -40° to +85°C. The polyurethane is non-marking, with high resistance to axial loading, and runs quietly. Used in conveyor applications, systems of transporting products along material handling systems or in areas of support for hanging structures or components, as found in;

- escalators
- overhead conveyors
- conveyors for letter & mail sorting
- baggage handling airport equipment

NAME		Vulkopan 59	
ABBREVIATION		WUPD	
COLOUR		LIGHT BROWN	
HARDNESS	SHORE D	59°	DIN 53505
TENSILE STRENGTH	MPa	50	DIN 53504
ELONGATION AT BREAK	%	500	DIN 53504
ABRASION RESISTANCE	mm ³	20	DIN 53516
COMPRESSION SET %	70 h / 23°C 70 h / 73.5°F	30	DIN 53517
	24 h / 70°C 24 h / 158°F	50	

'WU' GUIDE ROLLER TECHNICAL INFORMATION

Polyurethane 59° Shore D: Hardness

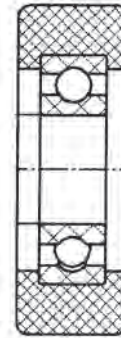

WU DP 018 006 004	18	6	4	684 ZZ	10	
WU DP 022 010 004	22	10	4	684 ZZ	20	
WU DP 025 010 006 S	25	10	6	626 2RS	20	
WU DP 025 010 006 Z	25	10	6	626 ZZ	20	
WU DP 026 012 006 Z	26	12	6	626 ZZ	25	
WU DP 030 011 008 S	30	11	8	608 2RS	30	
WU DP 030 011 008 Z	30	11	8	608 ZZ	30	
WU DP 030 011 009 S	30	11	9	609 2RS	20	
WU DP 030 011 009 Z	30	11	9	609 ZZ	20	
WU DP 032 016 008 S	32	16	8	608 2RS	45	
WU DP 032 016 008 Z	32	16	8	608 ZZ	45	
WU DP 035 009 006 S	35	9	6	626 2RS	40	
WU DP 035 011 008 S	35	11	8	608 2RS	40	
WU DP 035 011 008 Z	35	11	8	608 ZZ	40	
WU DP 035 015 010 Z	35	15	10	6000 ZZ	60	
WU DP 040 014 010 S	40	14	10	6200 2RS	70	
WU DP 040 014 010 Z	40	14	10	6200 ZZ	70	
WU DP 040 014 012 Z	40	14	12	6001 ZZ	70	
WU DP 040 020 010 S	40	20	10	6200 2RS	90	
WU DP 040 020 010 Z	40	20	10	6200 ZZ	90	
WU DP 040 025 010 Z	40	25	10	2X6000 ZZ	110	
WU DP 042 014 015 S	42	14	15	6002 2RS	80	
WU DP 044 012 012 Z	44	12	12	6001 ZZ	60	
WU DP 044 016 012 Z	44	16	12	6001 ZZ	80	
WU DP 045 013 012 Z	45	13	12	6001 ZZ	80	
WU DP 045 012 012 Z	45	15	12	6001 ZZ	80	
WU DP 047 013 012 Z	48	13	12	6001 ZZ	80	
WU DP 049 015 010 Z	49	15	10	6200 ZZ	80	
WU DP 050 012 015 Z	50	12	15	6002 ZZ	70	
WU DP 050 015 008 S	50	15	8	608 2RS	80	
WU DP 050 015 008 Z	50	15	8	608 ZZ	80	
WU DP 050 015 010 S	50	15	10	6200 2RS	100	
WU DP 050 015 010 Z	50	15	10	6200 ZZ	100	
WU DP 050 015 012 S	50	15	12	6201 2RS	100	
WU DP 050 015 012 Z	50	15	12	6201 ZZ	100	
WU DP 050 018 010 Z	50	18	10	6200 ZZ	100	
WU DP 050 018 012 S	50	18	12	6201 2RS	100	
WU DP 050 018 012 Z	50	18	12	6201 ZZ	100	
WU DP 050 018 015 S	50	18	15	6202 2RS	110	
WU DP 050 018 015 Z	50	18	15	6202 ZZ	110	
WU DP 050 018 017 S	50	18	17	6003 2RS	110	
WU DP 050 018 017 Z	50	18	17	6003 ZZ	110	
WU DP 050 025 012 S	50	25	12	6201 2RS	125	
WU DP 050 025 012 Z	50	25	12	6201 ZZ	125	
WU DP 050 025 015 Z	50	25	15	6202 ZZ	115	

WU DP 053 020 017 S	53	20	17	6203 2RS	75	
WU DP 055 020 012 Z	55	20	12	6201 ZZ	115	
WU DP 055 024 020 S	55	24	20	6204 2RS	80	
WU DP 055 024 020 Z	55	24	20	6204 ZZ	80	
WU DP 057 020 017 S	57	20	17	6203 2RS	135	
WU DP 057 020 017 Z	57	20	17	6203 ZZ	135	
WU DP 060 020 017 S	60	20	17	6203 2RS	150	
WU DP 060 020 017 Z	60	20	17	6203 ZZ	150	
WU DP 060 020 020 S	60	20	20	6004 2RS	150	
WU DP 060 020 020 Z	60	20	20	6004 ZZ	150	
WU DP 060 025 015 S	60	25	15	6202 SRS	150	
WU DP 060 025 015 Z	60	25	15	6202 ZZ	150	
WU DP 060 025 020 Z	60	25	20	6004 ZZ	150	
WU DP 062 020 017 Z	62	20	17	6203 ZZ	160	
WU DP 062 021 025 Z	62	21	25	6205 ZZ	180	
WU DP 063 020 017 Z	63	20	17	6203 ZZ	160	
WU DP 064 018 017 Z	64	18	17	6203 ZZ	150	
WU DP 064 020 017 Z	64	20	17	6203 ZZ	150	
WU DP 065 025 020 S	65	25	20	6204 2RS	150	
WU DP 065 025 020 Z	65	25	20	6204 ZZ	150	
WU DP 070 017 017 Z	70	17	17	6203 ZZ	100	
WU DP 070 025 020 S	70	25	20	6204 2RS	200	
WU DP 070 025 020 Z	70	25	20	6204 ZZ	200	
WU DP 070 035 020 Z	70	35	20	6204 ZZ	220	
WU DP 073 025 020 S	73	25	20	6204 2RS	210	
WU DP 073 025 020 Z	73	25	20	6204 ZZ	210	
WU DP 075 020 017 S	75	20	17	6303 2RS	160	
WU DP 075 020 017 Z	75	20	17	6303 ZZ	160	
WU DP 075 021 020 S	75	21	20	6204 2RS	160	
WU DP 075 021 020 Z	75	21	20	6204 ZZ	160	
WU DP 080 020 017 Z	80	20	17	6303 ZZ	175	
WU DP 080 025 025 S	80	25	25	6205 2RS	215	
WU DP 080 025 025 Z	80	25	25	6205 ZZ	215	
WU DP 085 025 020 Z	85	25	20	6304 ZZ	175	
WU DP 090 020 017 Z	90	20	17	6303 ZZ	195	
WU DP 090 020 025 Z	90	20	25	6205 ZZ	190	
WU DP 095 020 017 Z	95	20	17	6303 ZZ	170	
WU DP 100 025 025 Z	100	25	25	6205 ZZ	260	

Polyurethane 'Press-on Band' Tyred Wheels

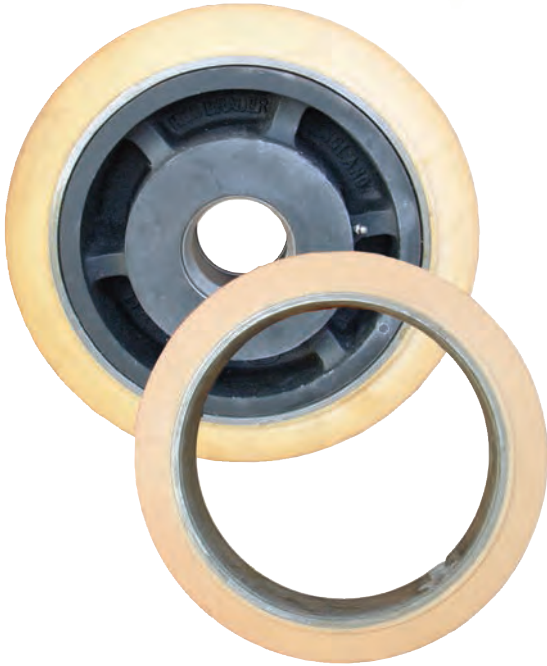

Unlike the less expensive polyurethane tyred wheels shown on pages 68-73 which have the tyre bonded directly to the wheel centre, 'Press-on Band' wheels have the tyre bonded to a thin steel band which is press-fitted to the wheel centre allowing the tyre to be replaced when worn.

MATERIAL: Wheel centre – cast iron to BS1452: 1977: Grade 200 or steel to BS970: Part 1: 1983: 080M40
Tyre – Polyester based polymer of $92 \pm 3^\circ\text{A}$ Shore hardness.

OPERATING TEMPERATURE RANGE:
-20°C to +60°C (115°C for limited intermittent use).

PLEASE SPECIFY IF OPERATING IN HIGH HUMIDITY.
Anti-hydrolysis polyurethane is recommended for use in an operating environment of high humidity.

Polyurethane to the above hardness used on these wheels is Vulkollan, a high quality material that provides superior performance in most applications.

Should the mechanical properties of Vulkollan be inappropriate for the application, alternative grades of Polyurethane can be produced to meet the requirements. Polyurethane can be bonded onto most metal centres including aluminium, titanium, stainless steel and various ferrous and non-ferrous alloys.

The 'maximum load rating' given for each wheel is for operation under ideal conditions. Load factors must be applied according to the anticipated working conditions – see 'Design Data' para. 5.1.

Alternative bore/bearing diameters and alternative bearing types (i.e. bronze bushes, self-lubricating bushes, roller bearings, spherical roller bearings, etc.) are available to order – see page 26-27.

For technical information covering load factors, chemical resistance, inertial and rolling resistance, coefficients of friction between wheel and track, and keyway dimensions, see "Design Data" Index on page 20.

Drawings show grease nipple but standard wheels do not come with grease nipple unless specifically requested.

Tyres can be produced with crown/dome treads to suit specific applications.

ALLOWABLE LOADS @ 6KPH

WHEEL TYPE:

PH250/75

See table for full part number

Maximum load rating:

2000Kg

See page 22-23 for load factors

Approximate weight: **20Kg**

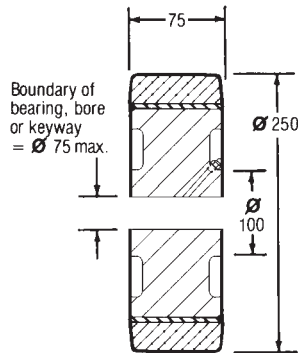

WHEEL TYPE:

PH250/125

See table for full part number

Maximum load rating:

3400Kg

See page 22-23 for load factors

Approximate weight: **33Kg**

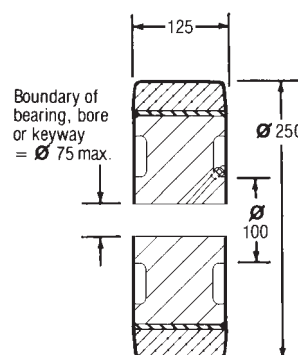

FULL PART NUMBER FOR ORDERING

Axle Ø	Plain Bore	Plain Bore Keywayed	Ball Bearing	Taper Roller Bearing
METRIC AXLE Ø				
35		PH250/75/KM 35	PH250/75/BJM 35	PH250/75/TBM 35
40		PH250/75/KM 40	PH250/75/BJM 40	PH250/75/TBM 40
50		PH250/75/KM 50	PH250/75/BJM 50	PH250/75/TBM 50

BAND ONLY PART NUMBER

PH250/3

Axle Ø	Plain Bore	Plain Bore Keywayed	Ball Bearing	Taper Roller Bearing
METRIC AXLE Ø				
35		PH250/125/KM 35	PH250/125/BJM 35	PH250/125/TBM 35
40		PH250/125/KM 40	PH250/125/BJM 40	PH250/125/TBM 40
50		PH250/125/KM 50	PH250/125/BJM 50	PH250/125/TBM 50

LOAD LIMITED BY BEARINGS TO: (1) 2800Kg (2) 3384Kg

BAND ONLY PART NUMBER

PH250/5

Polyurethane 'Press-on Band' Tyred Wheels



WHEEL TYPE:
PH300/75
See table for full part number

Maximum load rating:
2550kg
See page 22-23 for load factors
Approximate weight: 28kg

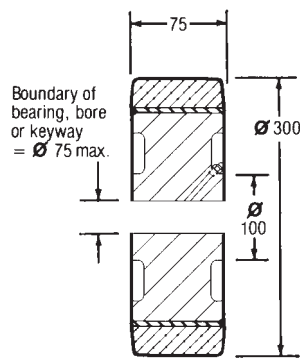

FULL PART NUMBER FOR ORDERING

Axle \varnothing	Plain Bore	Plain Bore Keywayed	Ball Bearing	Taper Roller Bearing
--------------------	------------	---------------------	--------------	----------------------

METRIC AXLE \varnothing				
40		PH300/75/KM 40	PH300/75/BJM 40	PH300/75/TBM 40
50		PH300/75/KM 50	PH300/75/BJM 50	PH300/75/TBM 50
60		PH300/75/KM 60	PH300/75/BJM 60	PH300/75/TBM 60

BAND ONLY PART NUMBER
PH300/3

WHEEL TYPE:
PH350/100
See table for full part number

Maximum load rating:
3600Kg
See page 22-23 for load factors
Approximate weight: 40Kg

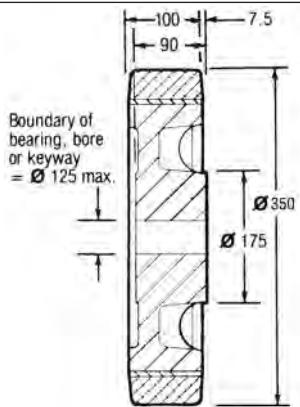

METRIC AXLE \varnothing				
50		PH350/100/KM 50	PH350/100/BJM 50	PH350/100/TBM 50
60		PH350/100/KM 60	PH350/100/BJM 60	PH350/100/TBM 60

BAND ONLY PART NUMBER
PH300/4

WHEEL TYPE:
PH380/75
See table for full part number

Maximum load rating:
2700Kg
See page 22-23 for load factors
Approximate weight: 36Kg

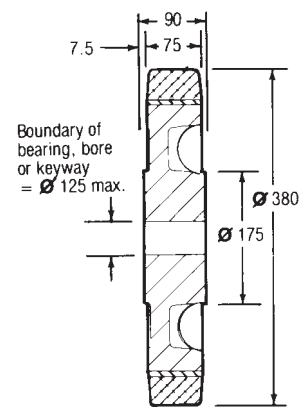

METRIC AXLE \varnothing				
50		PH380/75/KM 50	PH380/75/BJM 50	PH380/75/TBM 50
60		PH380/75/KM 60	PH380/75/BJM 60	PH380/75/TBM 60
75		PH380/75/KM 75	PH380/75/BJM 75	PH380/75/TBM 75

BAND ONLY PART NUMBER
PH380/3

WHEEL TYPE:
PH380/100
See table for full part number

Maximum load rating:
3600Kg
See page 22-23 for load factors
Approximate weight: 45Kg

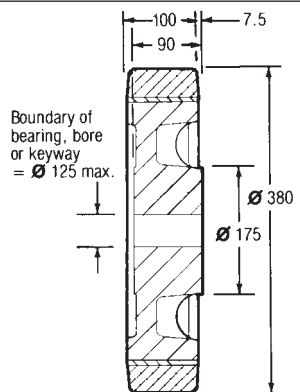

METRIC AXLE \varnothing				
60		PH380/100/KM 60	PH380/100/BJM 60	PH380/100/TBM 60
75		PH380/100/KM 75	PH380/100/BJM 75	PH380/100/TBM 75

BAND ONLY PART NUMBER
PH380/4

POLYURETHANE 'PRESS-ON-BAND'

WHEEL TYPE:
PH380/125
See table for full part number

Maximum load rating:
4500Kg
See page 22-23 for load factors
Approximate weight: 53Kg

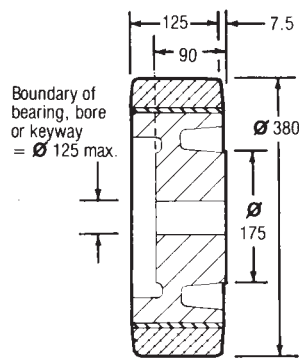

FULL PART NUMBER FOR ORDERING

Axle Ø	Plain Bore	Plain Bore Keywayed	Ball Bearing	Taper Roller Bearing
METRIC AXLE Ø				
60		PH380/125/KM 60	PH380/125/BJM 60	PH380/125/TBM 60
75		PH380/125/KM 75	PH380/125/BJM 75	PH380/125/TBM 75

BAND ONLY PART NUMBER
PH380/5

WHEEL TYPE:
PH400/100
See table for full part number

Maximum load rating:
3800Kg
See page 22-23 for load factors
Approximate weight: 65Kg

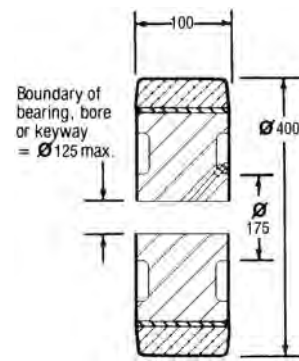

METRIC AXLE Ø				
60		PH400/100/KM 60	PH400/100/BJM 60	PH400/100/TBM 60
75		PH400/100/KM 75	PH400/100/BJM 75	PH400/100/TBM 75

BAND ONLY PART NUMBER
PH400/4

WHEEL TYPE:
PH400/125
See table for full part number

Maximum load rating:
4800Kg
See page 22-23 for load factors
Approximate weight: 80Kg

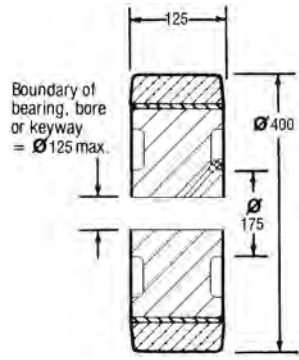

METRIC AXLE Ø				
60		PH400/125/KM 60	PH400/125/BJM 60	PH400/125/TBM 60
75		PH400/125/KM 75	PH400/125/BJM 75	PH400/125/TBM 75

BAND ONLY PART NUMBER
PH400/5

WHEEL TYPE:
PH460/75
See table for full part number

Maximum load rating:
3200Kg
See page 22-23 for load factors
Approximate weight: 45Kg

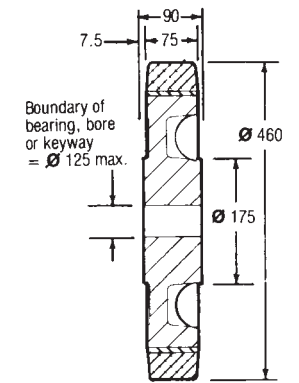

METRIC AXLE Ø				
60		PH460/75/KM 60	PH460/75/BJM 60	PH460/75/TBM 60
75		PH460/75/KM 75	PH460/75/BJM 75	PH460/75/TBM 75

BAND ONLY PART NUMBER
PH460/3

Polyurethane 'Press-on Band' Tyred Wheels



FULL PART NUMBER FOR ORDERING

Axle Ø	Plain Bore	Plain Bore Keywayed	Ball Bearing	Taper Roller Bearing
--------	------------	---------------------	--------------	----------------------

METRIC AXLE Ø				
60		PH460/100/KM 60	PH460/100/BJM 60	PH460/100/TBM 60
75		PH460/100/KM 75	PH460/100/BJM 75	PH460/100/TBM 75

BAND ONLY PART NUMBER

PH460/4

WHEEL TYPE: PH460/100

See table for full part number

Maximum load rating:
4200Kg

See page 22-23 for load factors

Approximate weight: **52Kg**

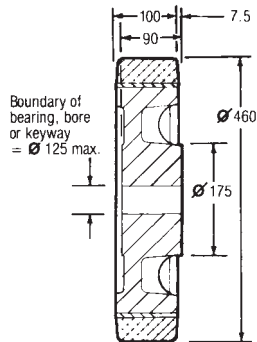

WHEEL TYPE: PH500/75

See table for full part number

Maximum load rating:
3600Kg

See page 22-23 for load factors

Approximate weight: **65Kg**

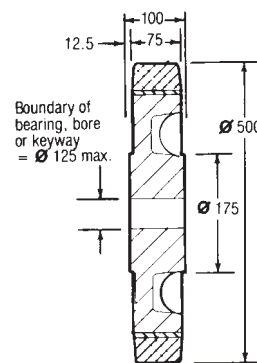

METRIC AXLE Ø

75		PH500/75/KM 75	PH500/75/BJM 75	PH500/75/TBM 75
100		PH500/75/KM 100	PH500/75/BJM 100	PH500/75/TBM 100

BAND ONLY PART NUMBER

PH500/3

WHEEL TYPE: PH500/100

See table for full part number

Maximum load rating:
4800Kg

See page 22-23 for load factors

Approximate weight: **70Kg**

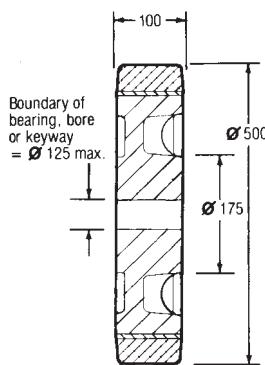

METRIC AXLE Ø

75		PH500/100/KM 75	PH500/100/BJM 75	PH500/100/TBM 75
100		PH500/100/KM 100	PH500/100/BJM 100	PH500/100/TBM 100

BAND ONLY PART NUMBER

PH500/4

POLYURETHANE 'PRESS-ON-BAND'



Rubber tyred wheels are the least expensive type of tyred wheel and are suitable for moderate loads. They are quiet in operation and protect the surface on which they run, although they can cause marking. Rubber tyres can generate static electricity, and where this is undesirable, 'anti-static' tyres can be specified.

MATERIAL: Wheel centre-cast iron to BS1452: 1977: Grade 200.

Tyre-carbon black reinforced natural rubber compound of 85±5°A Shore hardness.

OPERATING TEMPERATURE RANGE:

0°C to 50°C.

The 'maximum load rating' given for each wheel is for operation under ideal conditions. Load factors must be applied according to the anticipated working conditions – see 'Design Data' para. 3.1.

Alternative bore/bearing diameters and alternative bearing types (i.e. bronze bushes, self-lubricating bushes, roller bearings, spherical roller bearings, etc.) are available to order – see page 26-27.

For technical information covering load factors, inertial and rolling resistance, coefficients of friction between wheel and surface, and keyway dimensions, see "Design Data" Index on page 20.

Drawings show grease nipple but standard wheels do not come with grease nipple unless specifically requested.

FULL PART NUMBER FOR ORDERING

Axle Ø	Plain Bore	Plain Bore Keywayed	Ball Bearing	Taper Roller Bearing
METRIC AXLE Ø				
12	R100/40/PBM 12	R100/40/KM 12	R100/40/BJM 12	
20	R100/40/PBM 20	R100/40/KM 20	R100/40/BJM 20	
25	R100/40/PBM 25	R100/40/KM 25		

WHEEL TYPE:

R100/40

See table for full part number

Maximum load rating:

120Kg

See page 21 for load factors

Approximate weight: **1.5Kg**

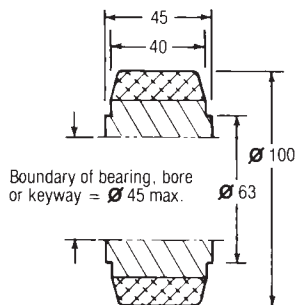

Wheels fitted with ball journals are pre-lubricated, double shielded

WHEEL TYPE:

R125/30

See table for full part number

Maximum load rating:

150Kg

See page 21 for load factors

Approximate weight: **1.5Kg**

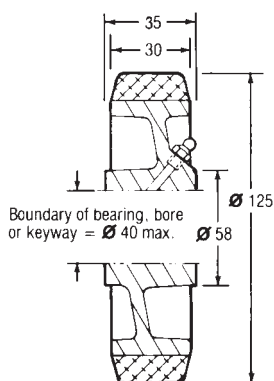

METRIC AXLE Ø

20	R125/30/PBM 20	R125/30/KM 20	R125/30/BJM 20	
25	R125/30/PBM 25	R125/30/KM 25		
30	R125/30/PBM 30	R125/30/KM 30		

Rubber Tyred Wheels



WHEEL TYPE:
R150/50

See table for full part number

Maximum load rating:
400Kg

See page 21 for load factors

Approximate weight: 3Kg

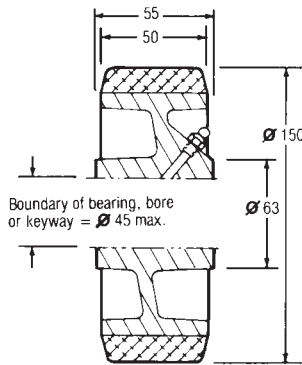

FULL PART NUMBER FOR ORDERING

Axle Ø	Plain Bore	Plain Bore Keywayed	Ball Bearing	Taper Roller Bearing
METRIC AXLE Ø				
20			R150/50/BJM 20	
25	R150/50/PBM 25	R150/50/KM 25	R150/50/BJM 25	
30	R150/50/PBM 30	R150/50/KM 30		

WHEEL TYPE:
R200/40

See table for full part number

Maximum load rating:
400Kg

See page 21 for load factors

Approximate weight: 4Kg

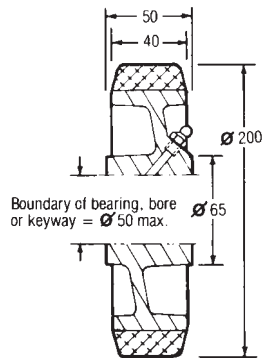

METRIC AXLE Ø



20			R200/40/BJM 20	
25	R200/40/PBM 25	R200/40/KM 25	R200/40/BJM 25	
30	R200/40/PBM 30	R200/40/KM 30		

Rubber Tyred 'Press-on Band'

- Cushion rubber ideal for use indoor and out
- Option of plain or treaded tyre
- Available with or without centre
- Centres supplied with a variety of bore sizes and types
- Standard sizes shown with others available on request



RUBBER PRESS-ON-BAND

Band Diameter	Band Width		Inner Diameter		Max Load (Kg)	Band Only	Band on Hub and Bearings	
						PART NUMBER	PART NUMBER	
15"	380	5"	125	11.25"	285.75	1240	PR380/125/286POB	PR380/125/BJM40
16.25"	412	5"	125	11.25"	285.75	1360	PR412/125/286POB	PR412/125/BJM40
18"	460	5"	125	12.125"	307.975	1470	PR460/125/308POB	PR460/125/BJM50

Nylon Wheels

BRAUER[®]



Plain untyred nylon wheels are the least expensive type of wheel. They are light in weight, and are resistant to impact, abrasion, corrosion, and the effect of many chemicals. They can be fitted with bearings but are most often used with their nylon bores running on a smooth steel axle. No lubrication is necessary, but they will benefit from being oiled. Having little resilience they tend to be noisiest when moving quickly over rough surfaces, and they can mark floors if highly loaded.

OPERATING TEMPERATURE RANGE: 5°C to 40°C
(-20°C to 80°C for limited use).

Nylon wheels are resistant to oils fats, alkalis in general, soaps and detergents but should not be used in contact with acids.

PART NUMBER:
N50/14/PBM12
PLAIN BORE

Maximum load rating:
80Kg

See page 21 for load factors

Approximate weight: 0.03Kg

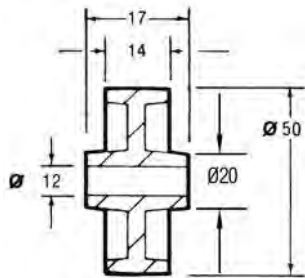

PART NUMBER:
N63/23/PBM11
PLAIN BORE

Maximum load rating:
85Kg

See page 21 for load factors

Approximate weight: 0.05Kg

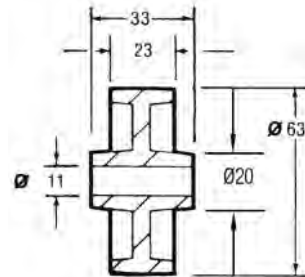

PART NUMBER:
N75/25/PBM12
PLAIN BORE

Maximum load rating:
120Kg

See page 21 for load factors

Approximate weight: 0.07Kg

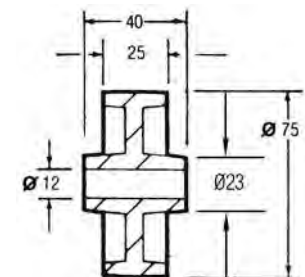

PART NUMBER:
N100/32/PBM15
PLAIN BORE

Maximum load rating:
225Kg

See page 21 for load factors

Approximate weight: 0.15Kg

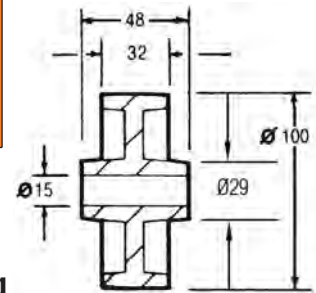

PART NUMBER:
N150/40/RBM20
ROLLER BEARING

Maximum load rating:
500Kg

See page 21 for load factors

Approximate weight: 0.5Kg

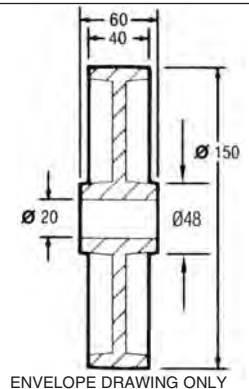

ENVELOPE DRAWING ONLY

PART NUMBER:
N250/60/BJM25
BALL JOURNAL

Maximum load rating:
2000Kg

See page 21 for load factors

Approximate weight: 2.3Kg

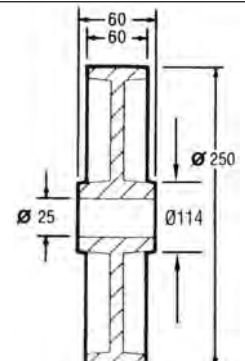

Fitted with pre-lubricated, double shielded bearings. ENVELOPE DRAWING ONLY

UNTYRED NYLON

COMPRESSION LOAD IN THIS DIRECTION (1)

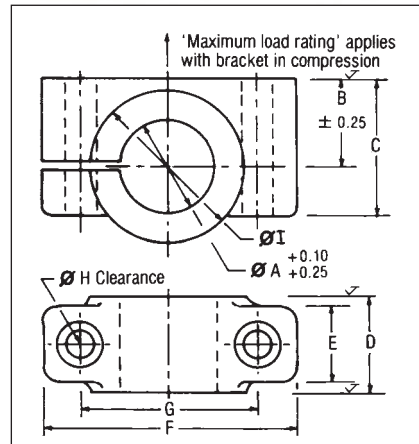
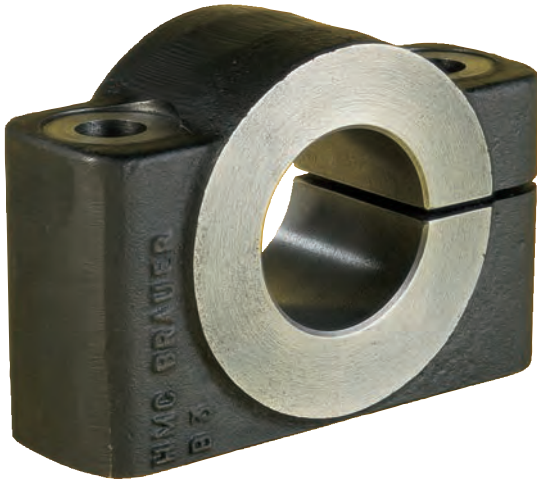

This series of four sizes of malleable cast iron axle brackets feature machined bores, bosses and mounting faces.

The brackets are slotted through one mounting hole, allowing the bracket to be positioned by bolting through the solid side, and the axle to be positioned laterally before being clamped by tightening the bolt through the slotted side.

MATERIAL: S.G. Cast Iron to BS2789: 1985: 420/12.

APPROXIMATE WEIGHTS:

B1 SERIES 1.3Kg B2 SERIES 2.3Kg

B3 SERIES 5.5Kg B4 SERIES 15Kg

Bolts can be supplied on request.

BRACKET SERIES	A Axle Ø	PART NUMBER	B	C	D	E	F	G	Ø H	Ø I	Maximum Load Rating
B1	25	B1/25	35	55	40	30	105	70	12	60	3500kg ⁽¹⁾
B1	30	B1/30	35	55	40	30	105	70	12	60	3500kg ⁽¹⁾
B1	35	B1/35	35	55	40	30	105	70	12	60	3500kg ⁽¹⁾
B1	40	B1/40	35	55	40	30	105	70	12	60	3500kg ⁽¹⁾
B2	45	B2/45	45	70	50	40	130	90	16	80	7000kg ⁽¹⁾
B2	50	B2/50	45	70	50	40	130	90	16	80	7000kg ⁽¹⁾
B3	60	B3/60	60	95	65	55	170	120	20	110	12000kg ⁽¹⁾
B3	70	B3/70	60	95	65	55	170	120	20	110	12000kg ⁽¹⁾
B4	75	B4/75	75	115	80	70	210	150	24	140	20000kg ⁽¹⁾
B4	80	B4/80	75	115	80	70	210	150	24	140	20000kg ⁽¹⁾

(1) The 'maximum load rating' applies with the bracket in compression as shown.

'A' Series Axle Assemblies

BRAUER[®]



These axle assemblies are for mounting pairs of wheels fitted with ball or roller bearings, the lock nuts and washers, or self locking nuts providing adjustment for opposed taper roller bearings.

Axle diameter 'A' and dimension 'D' should be selected to match the bearing bore and hub width of the wheels to be fitted.

The slotted axle brackets allow lateral positioning of the axle and wheels for alignment on installation – see "Axle Brackets" on page 86.

The assembly is supplied complete with axle brackets, bearing retaining/adjustment nuts, and locking washers.

AXLE MATERIAL:

Steel to BS970: Part 1:
1983:606M36 or 605M36.

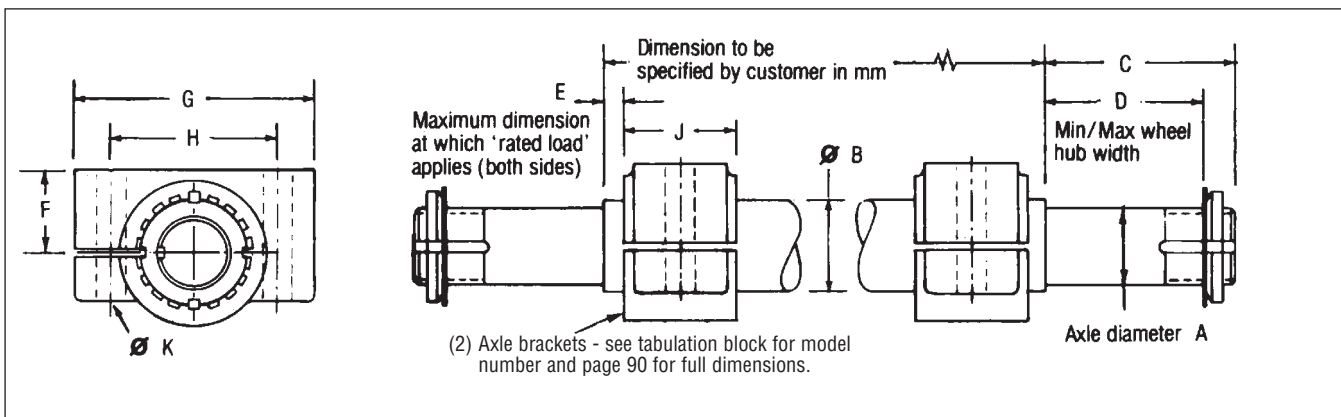

A Axle Ø	PART NUMBER	Max load rating kg*	Ø B	C	D		E	F	G	H	J	Ø K	AXLE BRACKET
					min	max							
25	A25/****	1500	30	62	40	52	75	35	105	70	40	12	B1/30
30	A30/****	2500	35	75	50	65	75	35	105	70	40	12	B1/35
35	A35/****	3000	40	97	60	85	100	35	105	70	40	12	B1/40
40	A40/****	4000	50	113	85	100	100	45	130	90	50	16	B2/50
50	A50/****	6300	60	128	85	110	120	60	170	120	65	20	B3/60
60	A60/****	8500	70	130	85	110	120	60	170	120	65	20	B3/70
75	A75/****	12000	85	150	85	110	150	75	210	150	80	24	B4/85

**** Denotes dimension between bearing abutment shoulders in mm to be specified by the customer.

* The 'Maximum Load Rating' applies per axle:

- i) to gradually applied loads. For shock loads multiply by a 'shock loading factor' of 0.65.
- ii) to radial loads only. Where axial loads are to be applied in conjunction with radial loads, refer to HMC-Brauer for allowable loads.
- iii) with axle brackets positioned within 'dimension E'.

'A' SERIES AXLE ASSEMBLIES

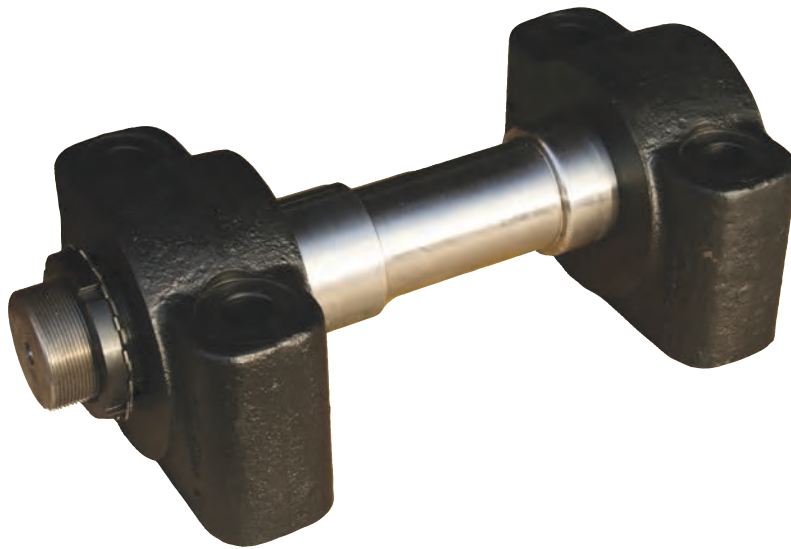

The 'BA' series axle assemblies are for mounting single wheels fitted with ball or roller bearings, the lock nut, lock washer, or self locking nuts and sleeve providing adjustment for opposed taper roller bearings.

Axle diameter 'A' and dimension 'D' should be selected to match the bearing bore and hub width of the wheels to be fitted.

The slotted axle brackets, in conjunction with the extended major axle diameter and sleeve (dimension 'C') allow a wide tolerance in the positioning of the brackets, and also allows the wheel to be positioned laterally between the brackets – see "Axle Brackets" on page 86.

The assembly is supplied complete with axle brackets, bearing retaining/adjustment nut and locking washer.

AXLE MATERIAL:

Steel to BS970: Part 1: 1983: 606M36 or 605M36.

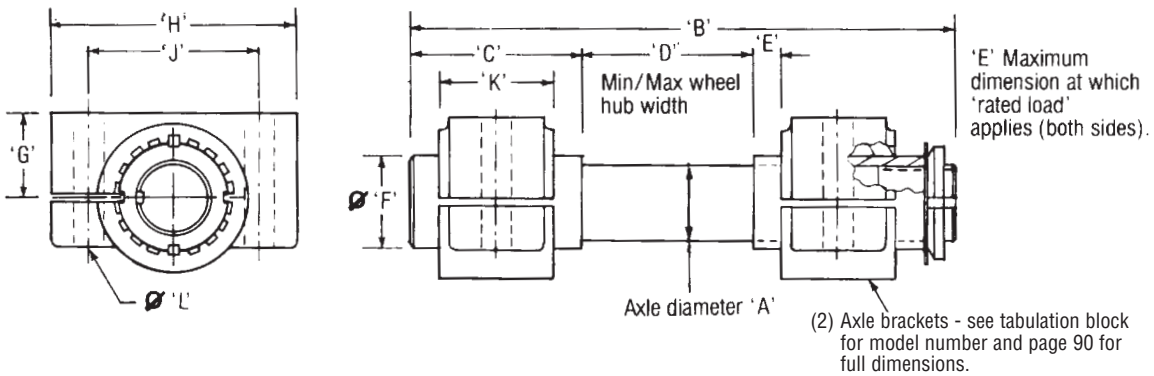

A Axle Ø	PART NUMBER	Max load rating kg*	B	C	D		E	Ø F	G	H	J	K	Ø L	AXLE BRACKET	Weight kg
					min	max									
30	BA30	3300	225	65	51	80	25	35	35	105	70	40	12	B1/35	4.0
35	BA35	7000	225	65	51	80	25	40	35	105	70	40	12	B1/40	4.7
40	BA40	9000	265	80	70	90	30	50	45	130	90	50	16	B2/50	8.9
50	BA50	14000	340	105	80	110	40	60	60	170	120	65	20	B3/60	19.0
60	BA60	24000	340	105	80	110	40	70	60	170	120	65	20	B3/70	21.3
75	BA75	40000	390	120	80	125	40	85	75	210	150	80	24	B4/85	38.1

* The 'Maximum Load Rating' applies:

- i) to gradually applied loads. For shock loads multiply by a 'shock loading factor' of 0.65.
- ii) to radial loads only. Where axial loads are to be applied in conjunction with radial loads, refer to HMC-Brauer for allowable loads.
- iii) with axle brackets positioned within 'dimension E'.

'CA' Series Axle Assemblies



This range of cantilevered stub axles is designed to mount single wheels with ball or roller bearings, the lock nut and lock washer, or self locking nuts providing adjustment for opposed taper roller bearings.

Axle diameter 'A' and dimension 'D' should be selected to match the bearing bore and hub width of the wheel to be fitted.

The assembly is supplied complete with bearing retaining/adjustment nut and locking washer, and a pair of half nuts for mounting.

AXLE MATERIAL:

Steel to BS970: Part 1: 1983: 606M36 or 605M36.

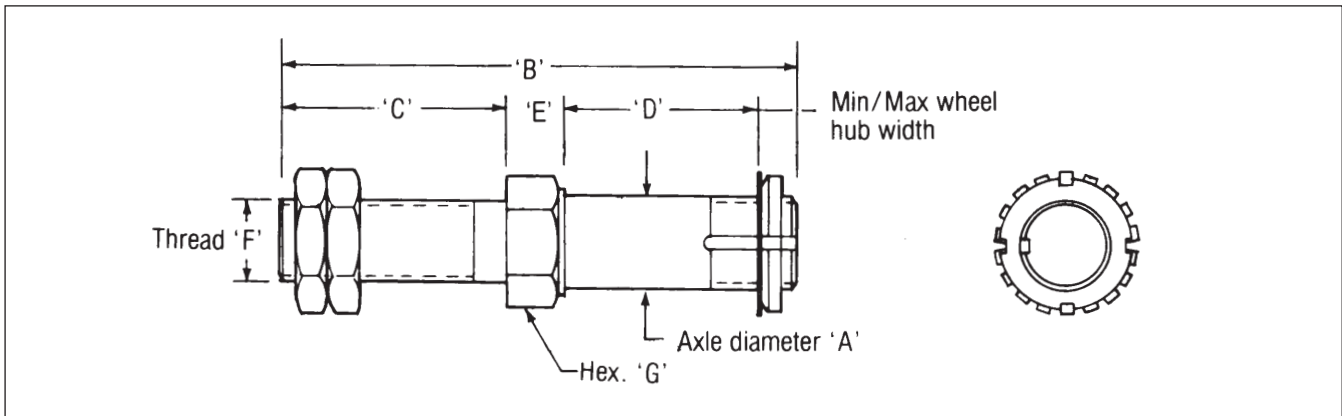

A Axle Ø	PART NUMBER	Max load rating kg*	B	C	D		E	Thread F	Hex G A/F	Recommended minimum mounting plate thickness	Weight kg
					min	max					
20	CA20	350	119	50	35	45	15	M27 x 2.0	32	12	0.7
25	CA25	600	137	60	40	52	15	M30 x 2.0	36	16	1.0
30	CA30	825	170	75	50	65	20	M36 x 3.0	46	18	1.7
35	CA35	1100	207	90	60	85	20	M42 x 3.0	50	22	2.5

* The 'Maximum Load Rating' applies:

- i) to gradually applied loads. For shock loads multiply by a 'shock loading factor' of 0.65.
- ii) to radial loads only. Where axial loads are to be applied in conjunction with radial loads, refer to HMC-Brauer for allowable loads.

'CA' SERIES AXLE ASSEMBLIES



PART NUMBERING Castors have descriptive part numbers as shown by the following example:

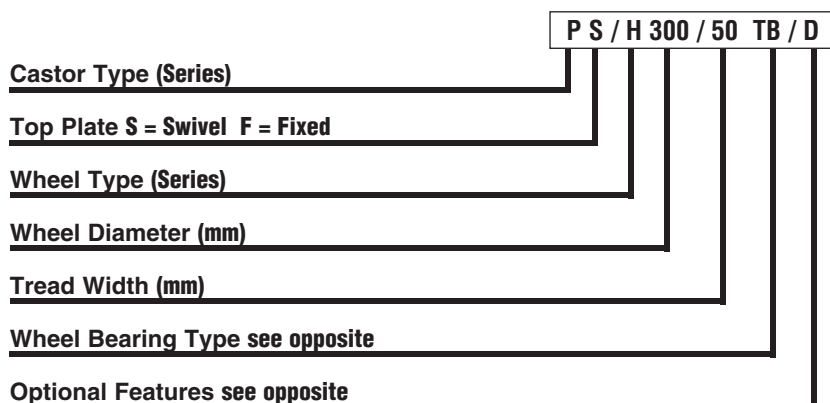

BEARING TYPES	
BJ	= Ball Journal
TB	= Taper Roller
CRB	= Cylindrical Roller
PB	= Plain Bore
SL	= Self Lubricating Bush
OPTIONAL FEATURES	
D	= Directional Lock
W	= Wheel Lock
T	= Thread Guard
B	= Footbrake
F	= Swivel & Wheel Lock
X	= Wheel Brake
S	= Head Seal

Non-catalogue items use the same descriptive part numbering system prefixed by the word specified, abbreviated as "spec".

Pivoting Castors

Load rating up to and exceeding 200 Tonne



Pivoting Castors generally consist of a pair of wheels rotating about a central axis.

A pair of wheels on a castor enable a lower overall height to be achieved compared to a single wheel castor of identical load capacity. The pivoting design ensures that the load is equally distributed over both wheels should the running surface be slightly uneven. This prevents overload on the wheels, a common problem with conventional twin wheel castor assemblies.

Multi-pivoting designs are used to spread the load over more than just one wheel which is not only beneficial for wear and lifetime working, but which also has the added advantage of reducing the overall height of a single wheel design.

These castors are designed to suit individual applications and can be supplied with stress analysis graphs using finite element analysis for the castor frame.

Brauer has many years experience in the design and manufacture of such assemblies with load ratings up to and exceeding 200 tonne. If you have a requirement simply fill in the design data sheet on page 19 and send it to our Sales team, alternatively email us as below.



PIVOTING CASTORS

Pneumatic Tyred Castor Single Wheel



- High speed applications (up to 10Kph)
- Multi-terrain operation capability
- Option for bespoke applications
- Incorporates reliability of WG swivel mechanism
- Brauer build quality assured
- Often adapted for towing applications

This new product further enhances the range of castors offered by Brauer designed to meet applications which have high load and speed requirements, such as freight handling and cargo dollies. The swivel and horn plates utilise our tried and tested WG castor range to give a reliable product with durability and strength.

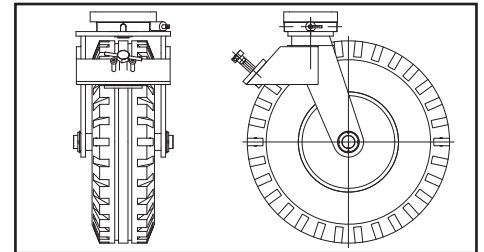

WHEEL FACE BRAKE OPTION
- SUFFIX 'WFB'

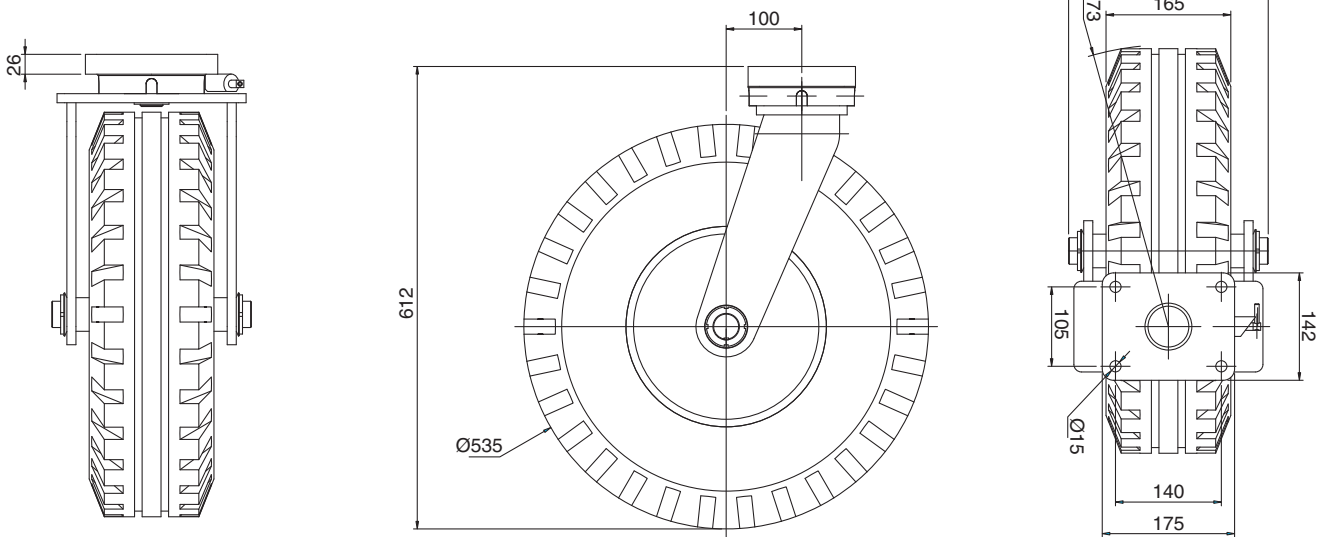

A	B	C	D			▽ Swivel		▽ Fixed	
Wheel Diameter	Overall Height	Swivel Radius	Tread Width	Max Load Rating	Wheel Bearing Type	PART NUMBER	Approx Weight kg	PART NUMBER	Approx Weight kg
535	612	373	165	2100	Ball Journal	WGS/PN535/165BJ	35	WGF/PN535/165BJ	30

PNEUMATIC TYRED SINGLE WHEEL

Pneumatic Tyred Castor Twin Wheel



- High speed applications (up to 10Kph)
- Multi-terrain operation capability
- Option for bespoke applications
- Incorporates reliability of TQZ swivel mechanism
- Brauer build quality assured
- Often adapted for towing applications

This new product further enhances the range of castors offered by Brauer designed to meet applications which have high load and speed requirements, such as freight handling and cargo dollies. The swivel and horn plates utilise our tried and tested TQZ castor range to give a reliable product with durability and strength.

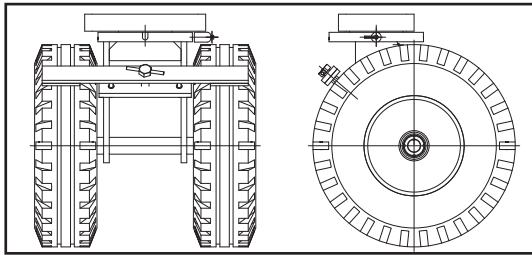

WHEEL FACE BRAKE OPTION - SUFFIX 'WFB'

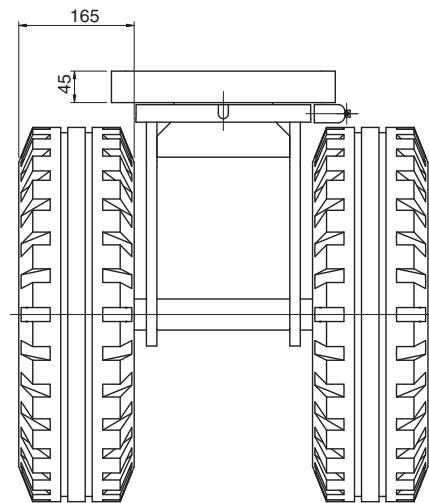
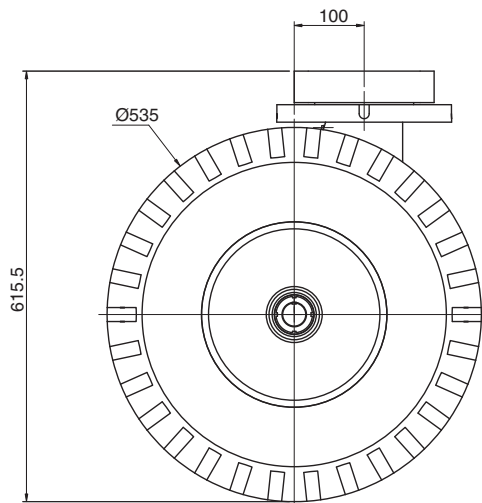
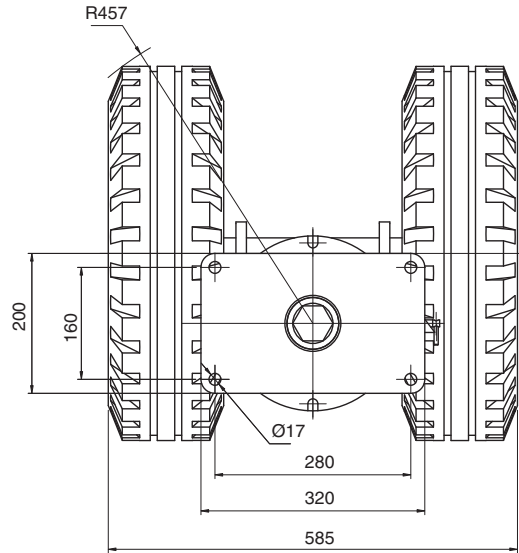

A	B	C	D			▽ Swivel		▽ Fixed	
Wheel Diameter	Overall Height	Swivel Radius	Tread Width	Max Load Rating	Wheel Bearing Type	PART NUMBER	Approx Weight kg	PART NUMBER	Approx Weight kg
535	615.5	457	165	4200	Ball Journal	TQZS/PN535/165BJ	70	TQZF/PN535/165BJ	60

PNEUMATIC TYRED TWIN WHEEL

The UHQZ, HQZ, TQZ, QZ, WG, TWG, GG and LG are made from precision machined components to ensure a long and trouble-free life, even under the most severe operating conditions.



DESIGN FEATURES

Precision hardened and ground ball thrust race ensures a smooth and free swivel action under heavy loads.

A swivel seal retains the grease which is packed on assembly and prevents the ingress of dirt or water.

A precision taper-roller bearing reacts to bending loads on the castor.

A self locking nut is adjusted on assembly to remove free play and to tightly pre-load the swivel bearings.

Steel top plate/king-post provides accurate alignment of the bearings and reliable strength.

Optional Directional Lock (locks in 4 positions 90° apart – add suffix D to the Part Number)

The taper roller bearing is shielded to retain grease and to prevent the ingress of dirt.

Optional Wheel Lock (Available on selected swivel and fixed castors - add suffix W to the Part Number)

Precision bearings fitted as standard

UHQZ Series

Swivel load rating 12000kg



WITH A VARIETY OF WHEEL OPTIONS (SEE TABLE BELOW)

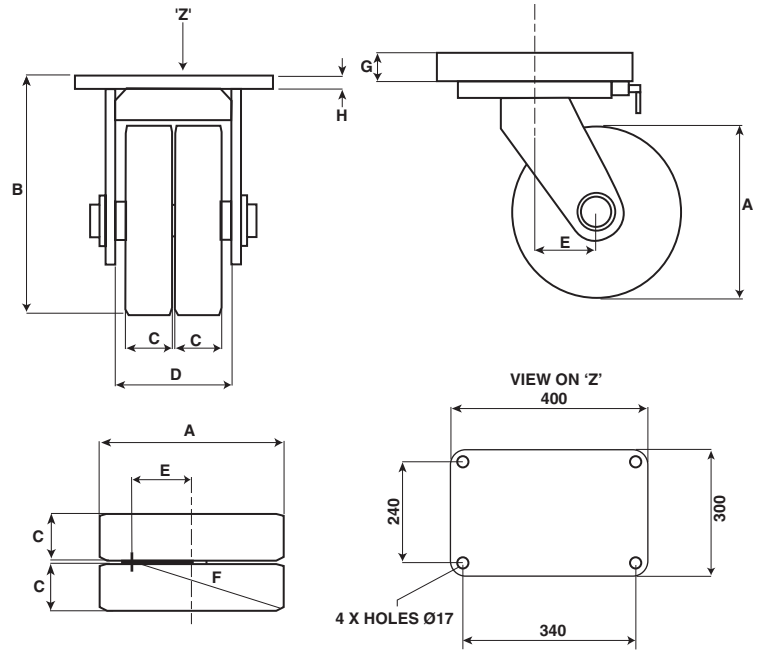

SWIVEL

Note: Steel Wheel option shown

Top plates have fixing holes to suit 16mm diameter bolts

Swivel top plate thickness 50mm (G)

Fixed top plate thickness 25mm (H)

FOR TECHNICAL INFORMATION COVERING LOAD FACTORS, ETC., SEE 'DESIGN DATA' INDEX ON PAGE 20

A	B	C	D	E	F			Swivel		Fixed	
Wheel Diameter	Overall Height	Tread Width	Dim. between Horn Plates	Wheel Centre Off-set	Swivel Radius	Max Load Rating	Wheel Bearing Type	PART NUMBER	Approx Weight kg	PART NUMBER	Approx Weight kg
DIRECT BOND POLYURETHANE TYRED WHEEL											
460	595	75	240	150	390	6400	Tapered Roller	UHQZS/H460/75TB	178	UHQZF/H460/75TB	130
POLYURETHANE TYRED 'PRESS-ON BAND' WHEEL											
500	635	100	240	150	412	9600	Tapered Roller	UHQZS/PH500/100TB	240	UHQZF/PH500/100TB	192
STEEL WHEEL											
350	465	110	130	150	330	12000	Tapered Roller	UHQZS/SFT350/110TB	180	UHQZF/SFT350/110TB	132

Note: Steel wheel is a single wheel

UHQZ SERIES CASTORS

Directional locks are standard on UHQZS series castors.

NOTE: Also available with other wheel types.

WITH A VARIETY OF WHEEL OPTIONS (SEE TABLE BELOW)

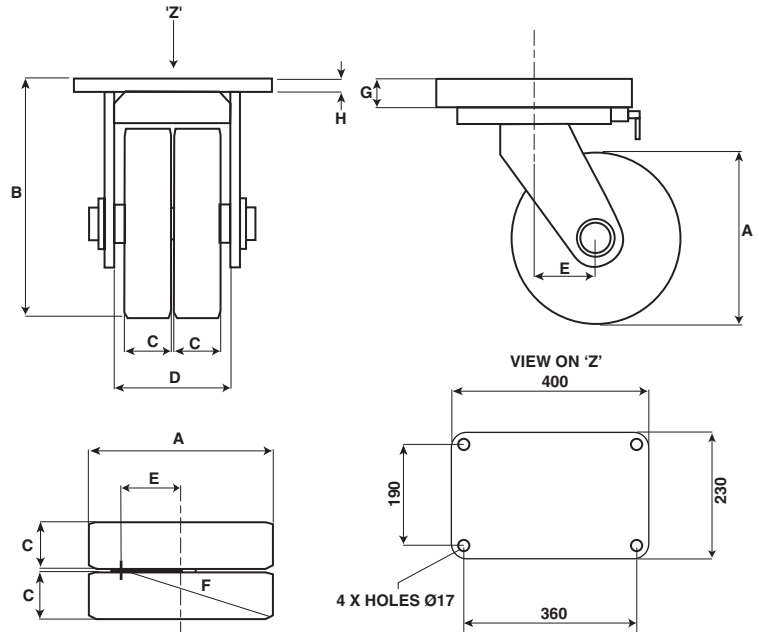

TWIN WHEEL FIXED

Note: Direct Bond Polyurethane Wheel shown

Top plates have fixing holes to suit 16mm diameter bolts

Swivel top plate thickness 50mm (G)

Fixed top plate thickness 20mm (H)

FOR TECHNICAL INFORMATION COVERING LOAD FACTORS, ETC., SEE 'DESIGN DATA' INDEX ON PAGE 20

A	B	C	D	E	F			▽ Swivel		▽ Fixed	
Wheel Diameter	Overall Height	Tread Width	Dim. between Horn Plates	Wheel Centre Off-set	Swivel Radius	Max Load Rating	Wheel Bearing Type	PART NUMBER	Approx Weight kg	PART NUMBER	Approx Weight kg
DIRECT BOND POLYURETHANE TYRED WHEEL											
300	435	100	240	100	270	6200	Tapered Roller	HQZS/H300/100TB	109	HQZF/H300/100TB	71
POLYURETHANE TYRED 'PRESS-ON BAND' WHEEL											
380	515	100	240	125	331	7200	Tapered Roller	HQZS/PH380/100TB	168	HQZF/PH380/100TB	127
STEEL WHEEL											
200	385	90	110	100	205	7300	Tapered Roller	HQZS/SFT200/90TB	95	HQZF/SFT200/90TB	57

Note: Steel wheel is a single wheel

Directional locks are standard on HQZS series castors.

NOTE: Also available with other wheel types.

TQZ Series

Swivel load rating 5100kg



WITH A VARIETY OF WHEEL OPTIONS (SEE TABLE BELOW)

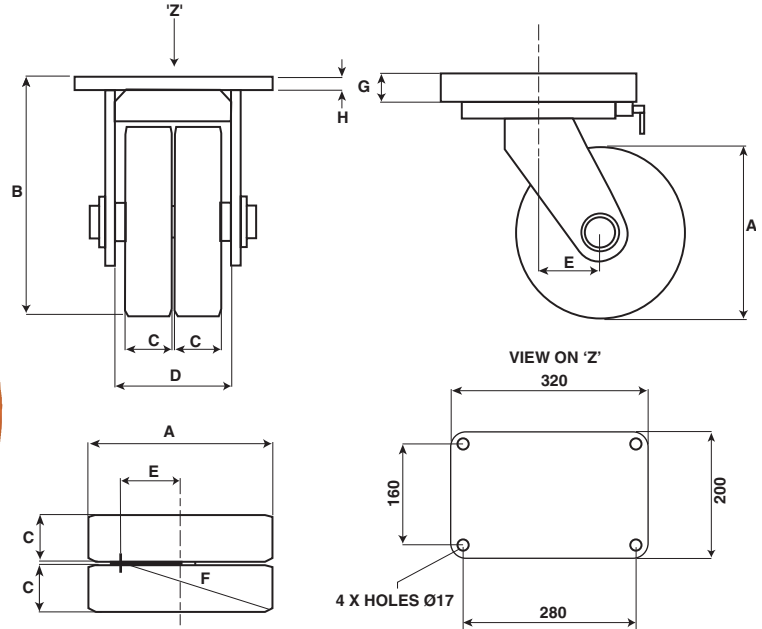

TWIN WHEEL SWIVEL

Note: Direct Bond Polyurethane Wheel shown

Top plates have fixing holes to suit 16mm diameter bolts

Swivel top plate thickness 45mm (G)

Fixed top plate thickness 20mm (H)

FOR TECHNICAL INFORMATION COVERING LOAD FACTORS, ETC., SEE 'DESIGN DATA' INDEX ON PAGE 20

A	B	C	D	E	F			Swivel		Fixed	
Wheel Diameter	Overall Height	Tread Width	Dim. between Horn Plates	Wheel Centre Off-set	Swivel Radius	Max Load Rating	Wheel Bearing Type	PART NUMBER	Approx Weight kg	PART NUMBER	Approx Weight kg
DIRECT BOND POLYURETHANE TYRED TWIN WHEEL											
250	355	70	190	85	222	4000	Tapered Roller	TQZS/H250/70TB	67	TQZF/H250/70TB	46
300	405	75	190	100	262	4600	Tapered Roller	TQZS/H300/75TB	76	TQZF/H300/75TB	55
POLYURETHANE TYRED 'PRESS-ON BAND' TWIN WHEEL											
250	355	75	190	85	224	4000	Tapered Roller	TQZS/PH250/75TB	83	TQZF/PH250/75TB	62
300	405	75	190	100	260	5000	Tapered Roller	TQZS/PH300/75TB	100	TQZF/PH300/75TB	79
STEEL WHEEL											
200	330	90	110	85	195	5100	Tapered Roller	TQZS/SFT200/90TB	66	TQZF/SFT200/90TB	55

TQZ SERIES CASTORS

Directional locks are standard on TQZS series castors.

NOTE: Also available with other wheel types.

WITH A VARIETY OF WHEEL OPTIONS (SEE TABLE BELOW)

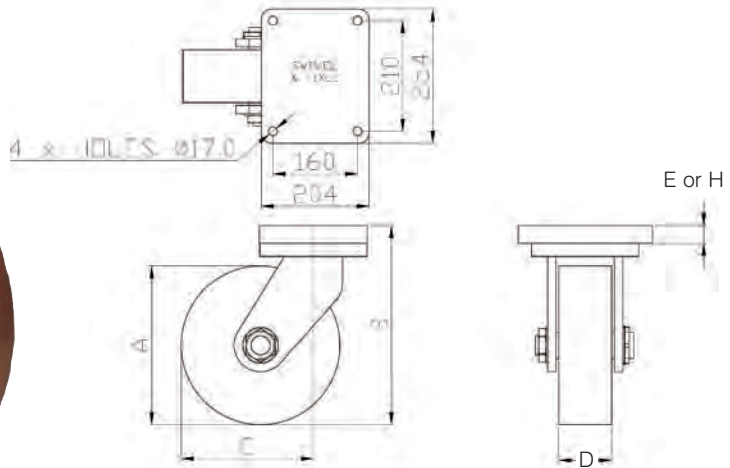

SWIVEL

Note: Press-on band polyurethane wheel shown

Top plates have fixing holes to suit 16mm diameter bolts

(E) Swivel top plate thickness 32mm
(H) Fixed top plate thickness 16mm

FOR TECHNICAL INFORMATION COVERING LOAD FACTORS, ETC., SEE 'DESIGN DATA' INDEX ON PAGE 20

A		B		C		D		▽ Swivel		▽ Fixed	
Wheel Diameter	Overall Height	Swivel Radius	Tread Width	Max Load Rating	Wheel Bearing Type	PART NUMBER	Approx Weight kg	PART NUMBER	Approx Weight kg		
POLYURETHANE TYRED WHEEL											
12"	300	375	250	100	3100	Taper Roller	QZS/H300/100TB	43	QZF/H300/100TB	43	
POLYURETHANE 'PRESS-ON BAND' TYRED WHEEL											
15"	380	450	315	100	3600	Taper Roller	QZS/PH380/100TB	70	QZF/PH380/100TB	70	
STEEL WHEEL											
8"	200	325	200	90	4200	Taper Roller	QZS/SFT200/90TB	47	QZF/SFT200/90TB	47	

NOTE: Also available with other wheel types.

Wheel locks and directional locks are available on QZ series swivel castors.
To order, add the appropriate suffix(es) to the castor part number: W = wheel lock D = directional lock.

TWG Series

Swivel load rating 3000kg



WITH A VARIETY OF WHEEL OPTIONS (SEE TABLE BELOW)

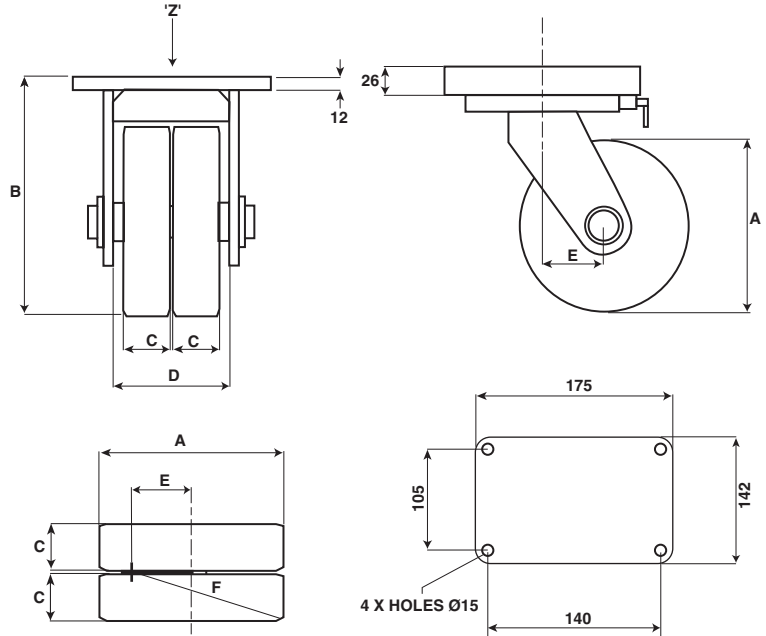

Top plates have fixing holes to suit 14mm diameter bolts

(E) Swivel top plate thickness 26mm

(H) Fixed top plate thickness 12mm

TWIN WHEEL SWIVEL

FOR TECHNICAL INFORMATION COVERING LOAD FACTORS, ETC., SEE 'DESIGN DATA' INDEX ON PAGE 20

A	B	C	D	E	F			Swivel		Fixed	
Wheel Diameter	Overall Height	Tread Width	Dim. between Horn Plates	Wheel Centre Off-set	Swivel Radius	Max Load Rating	Wheel Bearing Type	PART NUMBER	Approx Weight kg	PART NUMBER	Approx Weight kg
POLYURETHANE TYRED WHEEL											
150	220	35	90	50	131	1200	Tapered Roller	TWGS/H150/35TB	15	TWGF/H150/35TB	15

TWG SERIES CASTORS

Directional locks are standard on TWG series castors.

NOTE: Also available with other wheel types.

WITH A VARIETY OF WHEEL OPTIONS (SEE TABLE BELOW)

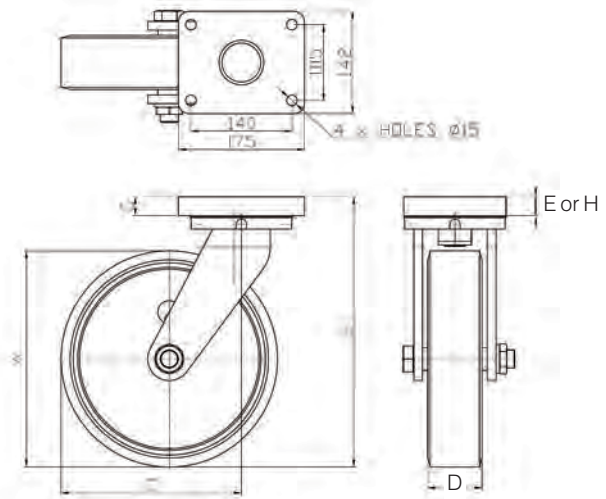

Top plates have fixing holes to suit 14mm diameter bolts

(E) Swivel top plate thickness 26mm

(H) Fixed top plate thickness 12mm

SWIVEL

Note: Direct Bond Polyurethane Wheel shown

FOR TECHNICAL INFORMATION COVERING LOAD FACTORS, ETC., SEE 'DESIGN DATA' INDEX ON PAGE 20

A		B		C		D		Swivel		Fixed	
Wheel Diameter	Overall Height	Swivel Radius	Tread Width	Max Load Rating	Wheel Bearing Type	PART NUMBER	Approx Weight kg	PART NUMBER	Approx Weight kg		
POLYURETHANE TYRED WHEEL											
6"	150	220	125	50	900	Taper Roller	WGS/H150/50TB	13	WGF/H150/50TB	13	
8"	200	265	160	75	1750	Taper Roller	WGS/H200/75TB	24.4	WGF/H200/75TB	24.4	
10"	250	310	200	70	2000	Taper Roller	WGS/H250/70TB	22	WGF/H250/70TB	22	
12"	300	375	250	75	2300	Taper Roller	WGS/H300/75TB	26	WGF/H300/75TB	26	
POLYURETHANE 'PRESS-ON-BAND' TYRED WHEEL											
10"	250	310	200	75	2000	Taper Roller	WGS/PH250/75TB	30	WGF/PH250/75TB	30	
12"	300	375	250	75	2500	Taper Roller	WGS/PH300/75TB	38	WGF/PH300/75TB	38	
STEEL WHEEL											
6"	150	220	125	40	3000	Taper Roller	WGS/SFT150/40TB	22	WGF/SFT150/40TB	22	

NOTE: Also available with other wheel types.

Wheel locks and directional locks are available on WG series swivel castors.

To order, add the appropriate suffix(es) to the castor part number: W = wheel lock D = directional lock.

Medium Duty Castors

GG Series

Swivel load rating 1500kg



WITH A VARIETY OF WHEEL OPTIONS (SEE TABLE BELOW)

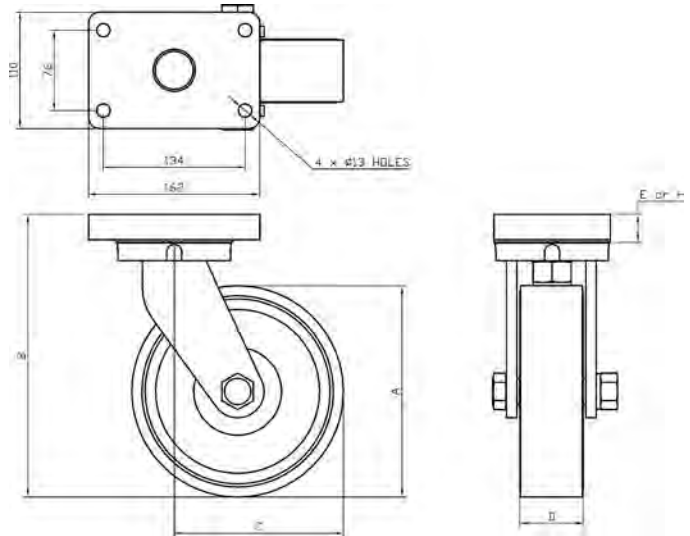

SWIVEL

Note: Direct Bond Polyurethane Wheel shown

Top plates have fixing holes to suit 12mm diameter bolts

(E) Swivel top plate thickness 24mm

(H) Fixed top plate thickness 12mm

FOR TECHNICAL INFORMATION COVERING LOAD FACTORS, ETC., SEE 'DESIGN DATA' INDEX ON PAGE 20

A	B	C	D			▽ Swivel		▽ Fixed		
Wheel Diameter	Overall Height	Swivel Radius	Tread Width	Max Load Rating	Wheel Bearing Type	PART NUMBER	Approx Weight kg	PART NUMBER	Approx Weight kg	
POLYURETHANE TYRED WHEEL										
4"	100	165	90	40	450	Ball Journal	GGG/H100/40BJ	8	GGF/H100/40BJ	8
6"	150	216	125	50	900	Ball Journal	GGG/H150/50BJ	9	GGF/H150/50BJ	9
8"	200	267	160	40	900	Ball Journal	GGG/H200/40BJ	11	GGF/H200/40BJ	11
10"	250	318	195	45	1300	Ball Journal	GGG/H250/45BJ	16	GGF/H250/45BJ	16

NOTE: Also available with other wheel types.

Wheel locks and directional locks are available on WG series swivel castors.

To order, add the appropriate suffix(es) to the castor part number: W = wheel lock D = directional lock.

GG SERIES CASTORS

Medium-Light Duty Castors

LG Series

Swivel load rating 1000kg

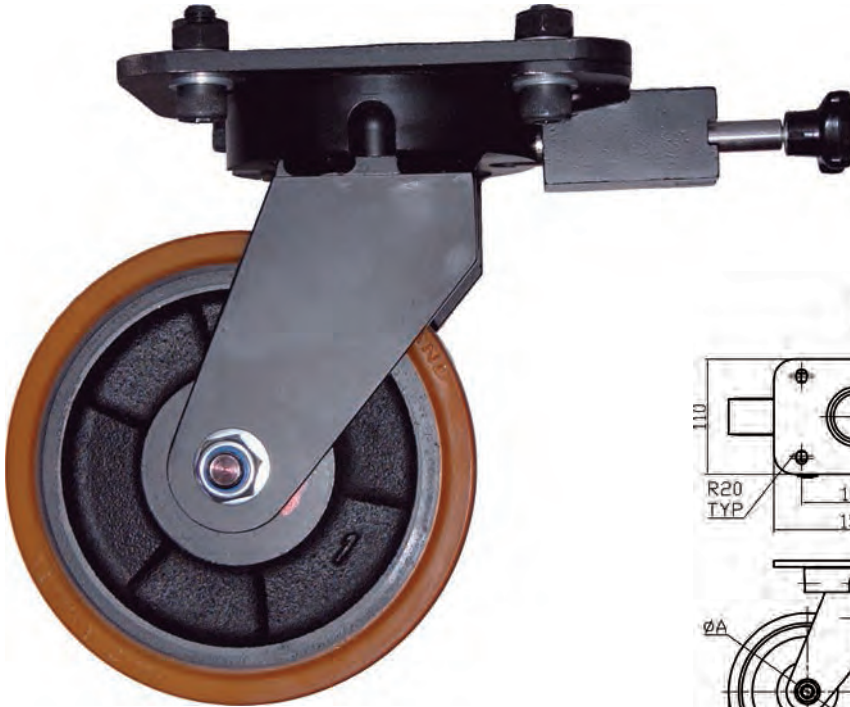

SWIVEL

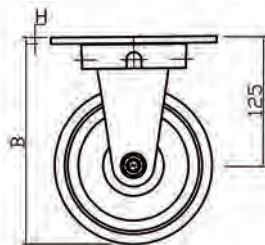
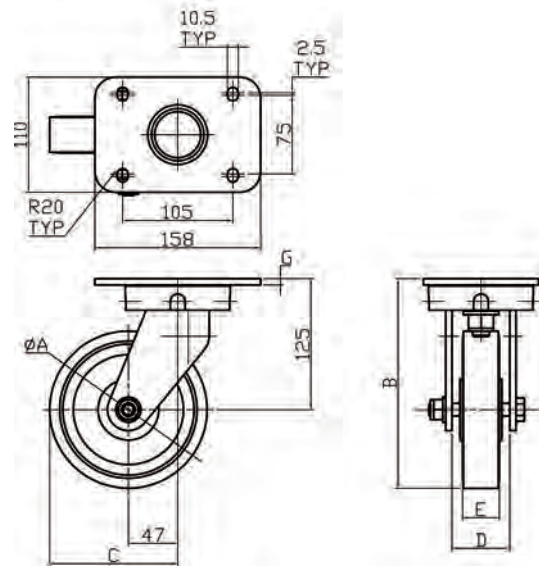

FIXED

Top plates have fixing holes to suit 10mm diameter bolts

(G) Swivel top plate thickness 6mm

(H) Fixed top plate thickness 6mm

FOR TECHNICAL INFORMATION COVERING LOAD FACTORS, ETC., SEE 'DESIGN DATA' INDEX ON PAGE 20

A	B	C	D	E			▽ Swivel		▽ Fixed	
Wheel Diameter	Overall Height	Swivel Radius	Dim. between Horn Plates	Tread Width	Max Load Rating kg	Wheel Bearing Type	PART NUMBER	Approx Weight kg	PART NUMBER	Approx Weight kg
POLYURETHANE TYRED WHEEL										
150	200	122	55	35	600	Ball Journal	LGS/H150/35BJ	8	LGF/H150/35BJ	8
125	187.5	110	55	45	600	Ball Journal	LGS/H125/45BJ	7	LGF/H125/45BJ	7
125	187.5	110	55	30	400	Ball Journal	LGS/H125/30BJ	7	LGF/H125/30BJ	7

NOTE: Also available with other wheel types.

Wheel locks and directional locks are available on WG series swivel castors.

To order, add the appropriate suffix(es) to the castor part number: W = wheel lock D = directional lock.

H Series

Swivel load rating 1500kg



SWIVEL



FIXED

Wheel Dia.	Plate Size	Hole Centres	Fixing Bolt Dia.
100	150 x 110	120/105 x 80/60	10
125	150 x 110	120/105 x 80/60	10
150	150 x 110	120/105 x 80/60	10
200	150 x 110	120/105 x 80/60	10
250	150 x 110	120/105 x 80/60	10
300	150 x 110	120/105 x 80/60	10

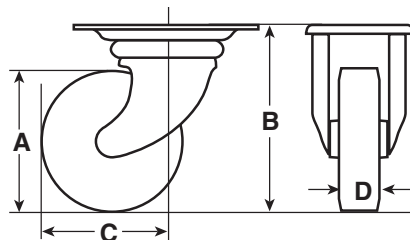

Wheel Dia.	Plate Size	Hole Centres	Fixing Bolt Dia.
100	150 x 115	120/105 x 80/60	10
125	150 x 115	120/105 x 80/60	10
150	150 x 115	120/105 x 80/60	10
200	150 x 115	120/105 x 80/60	10
250	150 x 115	120/105 x 80/60	10
300	150 x 115	120/105 x 80/60	10

FOR TECHNICAL INFORMATION COVERING LOAD FACTORS, ETC., SEE 'DESIGN DATA' INDEX ON PAGE 20

A	B	C	D	Swivel			Fixed		
Wheel Diameter	Overall Height	Swivel Radius	Tread Width	Max Load Rating	Wheel Bearing Type	PART NUMBER	Approx Weight kg	PART NUMBER	Approx Weight kg
CAST IRON CENTRED WHEEL WITH POLYURETHANE TYRE									
100	152	102	40	450	Ball Journal	HS/H100/40BJ	3.9	HF/H100/40BJ	3
125	177	118	30	400	Ball Journal	HS/H125/30BJ	4	HF/H125/30BJ	3.1
			45	600	Ball Journal	HS/H125/45BJ	4.5	HF/H125/45BJ	3.6
150	202	134	35	600	Ball Journal	HS/H150/35BJ	4.6	HF/H150/35BJ	3.7
			50	900	Ball Journal	HS/H150/50BJ	5.6	HF/H150/50BJ	4.7
200	252	166	40	900	Ball Journal	HS/H200/40BJ	6.7	HF/H200/40BJ	5.8
250	303	207	45	1300	Ball Journal	HS/H250/45BJ	9.8	HF/H250/45BJ	8.9
300	353	245	50	1500	Ball Journal	HS/H300/50BJ	12.9	HF/H300/50BJ	12

NOTE 1) 100mm diameter wheel fitted with pre-lubricated, double shielded bearings
2) Options F – swivel radius of brake pedal 178mm

OPTIONS AVAILABLE

NOTE: Also available with other wheel types.

WHEEL LOCK (W)
Swivel castors only, not available for 100mm dia. wheel

A simple hand operated parking lock

Add suffix W to part number

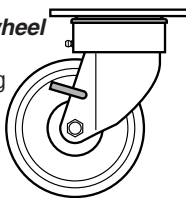

SWIVEL AND WHEEL LOCK (F)
Swivel castors only 125-300mm only

The foot pedal clamps a spring across the wheel & swivel, locking them both

Add suffix F to part number

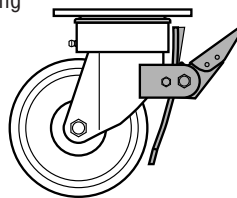

DIRECTIONAL LOCK (D)
Swivel castors only

A four-station plunger lock converting swivel castors into fixed for straight line travel

Add suffix D to part number

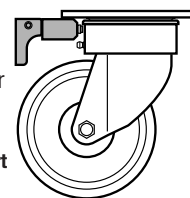

H SERIES CASTORS

Light Duty Castors F Series

Swivel load rating 380kg



SWIVEL



FIXED

(NOTE: swivel lock and brake fitted as standard)

SWIVEL CASTORS TOP PLATE DIMENSIONS

Wheel Dia.	Plate Size	Hole Centres	Fixing Bolt Dia.
75	105 x 85	83/76 x 64/56	8
100	105 x 85	83/76 x 64/56	8
125	135 x 110	105 x 75/85	10
150	135 x 110	105 x 75/85	10

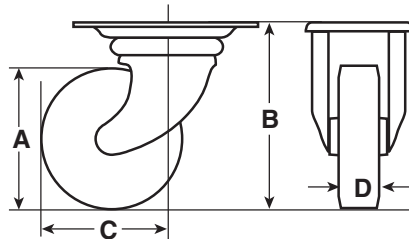

FIXED CASTORS TOP PLATE DIMENSIONS

Wheel Dia.	Plate Size	Hole Centres	Fixing Bolt Dia.
75	105 x 85	83/76 x 64/56	8
100	105 x 85	83/76 x 64/56	8
125	140 x 114	105 x 75/85	10
150	140 x 114	105 x 75/85	10

FOR TECHNICAL INFORMATION COVERING LOAD FACTORS, ETC., SEE 'DESIGN DATA' INDEX ON PAGE 20

A		B		C		D		Swivel		Fixed	
Wheel Diameter	Overall Height	Swivel Radius	Tread Width	Max Load Rating	Wheel Bearing Type	PART NUMBER	Approx Weight kg	PART NUMBER	Approx Weight kg		
CAST IRON CENTRED WHEEL WITH POLYURETHANE TYRE											
75	106	75	35	300	Ball Journal	FS/H75/35BJ/L	1.8	FF/H75/35BJ	0.8		
100	128	87	40	360	Ball Journal	FS/H100/40BJ/L	2.9	FF/H100/40BJ	1.9		
125	160	117	30	360	Ball Journal	FS/H125/30BJ/L	3.0	FF/H125/30BJ	2.0		
150	190	130	35	380	Ball Journal	FS/H150/35BJ/L	3.6	FF/H150/35BJ	2.6		

NOTE: Also available with other wheel types.

E Series

Swivel load rating 380kg



SWIVEL

(NOTE: swivel lock and brake fitted as standard)



FIXED

SWIVEL CASTORS TOP PLATE DIMENSIONS

Wheel Dia.	Plate Size	Hole Centres	Fixing Bolt Dia.
125	135 x 110	105 x 75/85	10
150	135 x 110	105 x 75/85	10
200	135 x 110	105 x 75/85	10

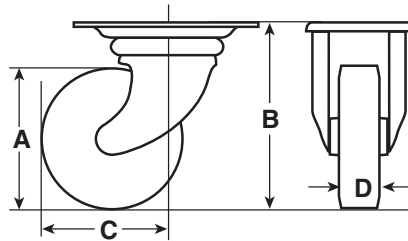

FIXED CASTORS TOP PLATE DIMENSIONS

Wheel Dia.	Plate Size	Hole Centres	Fixing Bolt Dia.
125	140 x 114	105 x 75/85	10
150	140 x 114	105 x 75/85	10
200	140 x 114	105 x 75/85	10

FOR TECHNICAL INFORMATION COVERING LOAD FACTORS, ETC., SEE 'DESIGN DATA' INDEX ON PAGE 20

A	B	C	D	Swivel			Fixed		
Wheel Diameter	Overall Height	Swivel Radius	Tread Width	Max Load Rating	Wheel Bearing Type	PART NUMBER	Approx Weight kg	PART NUMBER	Approx Weight kg
POLYPROPYLENE CENTRED WHEEL WITH POLYURETHANE TYRE									
125	160	117	45	300	Ball Journal	ES/PP125/45BJ/L	2.4	EF/PP125/45BJ	1.5
150	190	130	45	340	Ball Journal	ES/PP150/45BJ/L	2.7	EF/PP150/45BJ	1.8
200	240	155	45	380	Ball Journal	ES/PP200/45BJ/L	3.3	EF/PP200/45BJ	2.4

NOTE: Also available with other wheel types.

E SERIES CASTORS



SWIVEL



FIXED

(NOTE: swivel lock and brake fitted as standard)

SWIVEL CASTORS TOP PLATE DIMENSIONS

Wheel Dia.	Plate Size	Hole Centres	Fixing Bolt Dia.
80	105 x 85	83/76 x 64/56	8
100	105 x 85	83/76 x 64/56	8
125	135 x 110	105 x 75/85	10
160	135 x 110	105 x 75/85	10
200	135 x 110	105 x 75/85	10

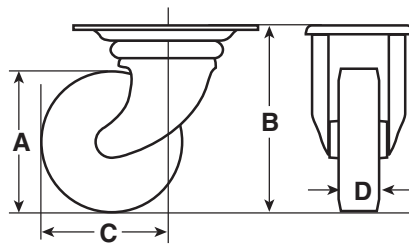

FIXED CASTORS TOP PLATE DIMENSIONS

Wheel Dia.	Plate Size	Hole Centres	Fixing Bolt Dia.
80	105 x 85	83/76 x 64/56	8
100	105 x 85	83/76 x 64/56	8
125	140 x 114	105 x 75/85	10
160	140 x 114	105 x 75/85	10
200	140 x 114	105 x 75/85	10

FOR TECHNICAL INFORMATION COVERING LOAD FACTORS, ETC., SEE 'DESIGN DATA' INDEX ON PAGE 20

A		B		C		D		Swivel		Fixed	
Wheel Diameter	Overall Height	Swivel Radius	Tread Width	Max Load Rating	Wheel Bearing Type	PART NUMBER	Approx Weight kg	PART NUMBER	Approx Weight kg		
NYLON CENTRED WHEEL WITH POLYURETHANE TYRE											
80	108	77	30	100	Ball Journal	ES/PN80/30BJ/L	1	EF/PN80/30BJ	0.7		
100	128	87	30	120	Ball Journal	ES/PN100/30BJ/L	1.1	EF/PN100/30BJ	0.8		
125	156	104	40	150	Ball Journal	ES/PN125/40BJ/L	1.5	EF/PN125/40BJ	1.1		
160	195	135	45	300	Ball Journal	ES/PN160/45BJ/L	2.5	EF/PN160/45BJ	1.7		
200	240	155	50	350	Ball Journal	ES/PN200/50BJ/L	3	EF/PN200/50BJ	2.1		

E Series

Swivel load rating 250kg



HIGH TEMPERATURE PHENOLIC WHEEL MAXIMUM TEMPERATURE 220°C

Note: Swivel Bracket is supplied un-greased



SWIVEL



FIXED

(NOTE: swivel lock and brake fitted as standard)

SWIVEL CASTORS TOP PLATE DIMENSIONS

Wheel Dia.	Plate Size	Hole Centres	Fixing Bolt Dia.
76	105 x 85	83/76 x 64/56	8
100	105 x 85	83/76 x 64/56	8
125	135 x 110	105 x 75/85	10
150	135 x 110	105 x 75/85	10

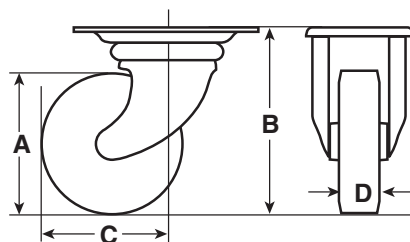

FIXED CASTORS TOP PLATE DIMENSIONS

Wheel Dia.	Plate Size	Hole Centres	Fixing Bolt Dia.
76	105 x 85	83/76 x 64/56	8
100	105 x 85	83/76 x 64/56	8
125	140 x 114	105 x 75/85	10
150	140 x 114	105 x 75/85	10

FOR TECHNICAL INFORMATION COVERING LOAD FACTORS, ETC., SEE 'DESIGN DATA' INDEX ON PAGE 20

A	B	C	D			Swivel	Fixed		
Wheel Diameter	Overall Height	Swivel Radius	Tread Width	Max Load Rating	Wheel Bearing Type	PART NUMBER	Approx Weight kg	PART NUMBER	Approx Weight kg
HIGH TEMPERATURE SOLID PHENOLIC WHEEL									
76	106	75	30	100	None	ES/HT76/30PB/L	0.9	EF/HT76/30PB	0.6
100	128	87	32	150	None	ES/HT100/32PB/L	1	EF/HT100/32PB	0.7
125	160	117	50	200	None	ES/HT125/50PB/L	2.7	EF/HT125/50PB	1.8
150	190	130	50	250	None	ES/HT150/50PB/L	3	EF/HT150/50BPB	2.2

E SERIES CASTORS

Jacking Units

JBG Series

Load rating 600kg

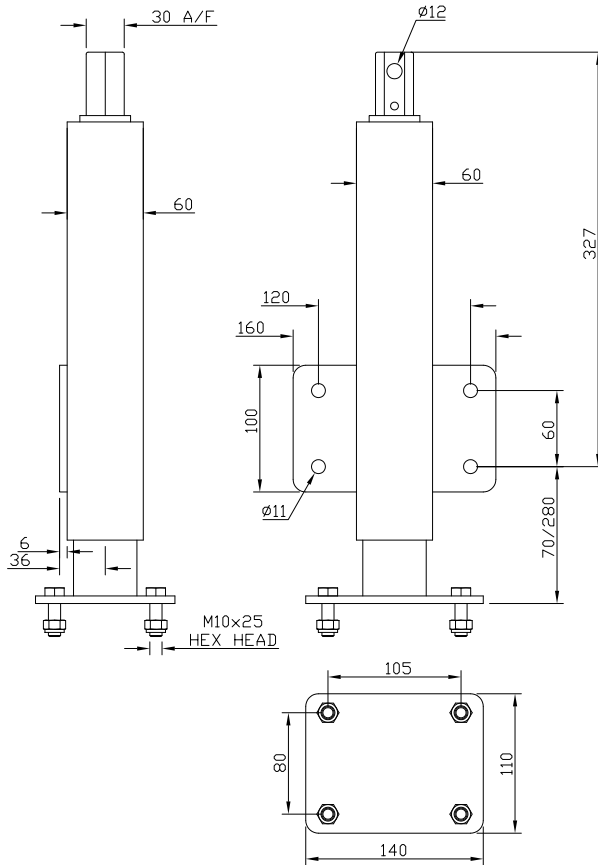

Brauer has designed and developed a range of four jacking units, which now cover the full loading spectrum for jacking unit use, where lifting by raising a trailer, flat bed or trolley bed on castors or without castors (flat footed) to align with a docking area, is required. The family consist of the lighter loaded JBG series which has a capacity of 600Kg right up to the heavy duty JWG series with loading capacities of 2500Kg per jacking unit. Quality, design and availability are enhanced, as all four of the Brauer jacking units are made at our Milton Keynes facility. The JBG has been designed to suit our HA castor range which has wheel options, from 125mm to 200mm diameter and uses an aluminium centred wheel with a polyurethane tyre. The JBG jacking unit is offered generally, but not exclusively, with the swivel castor option. Other wheel and castor types can be fitted to all models of the Brauer jacking units, should this be a consideration please contact Brauer sales.

SWIVEL CASTORS TOP PLATE DIMENSIONS			
Wheel Dia.	Plate Size	Hole Centres	Fixing Bolt Dia.
125	135 x 110	105 x 80	10
150	135 x 110	105 x 80	10
200	135 x 110	105 x 80	10

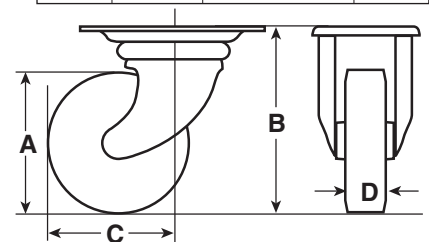

FOR TECHNICAL INFORMATION COVERING LOAD FACTORS, ETC., SEE 'DESIGN DATA' INDEX ON PAGE 20

A	B	C	D			Swivel	
Wheel Diameter	Overall Height	Swivel Radius	Tread Width	Max Load Rating	Wheel Bearing Type	PART NUMBER	Approx Weight kg
ALUMINIUM CENTRED WHEEL WITH POLYURETHANE TYRE							
125	156	118	50	350	Ball Journal	JBG/HA125/50BJ	8
150	196	130	50	400	Ball Journal	JBG/HA150/50BJ	9
200	240	155	50	500	Ball Journal	JBG/HA200/50BJ	10
JACKING UNIT ONLY						JU600	6

600KG JACKING UNIT

JGG Series

Load rating 1000kg

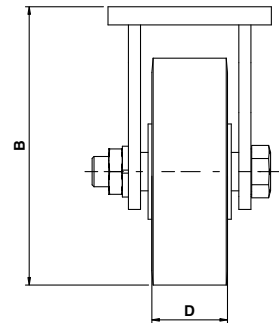
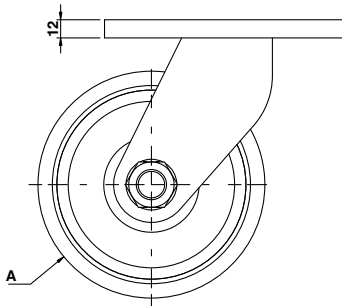
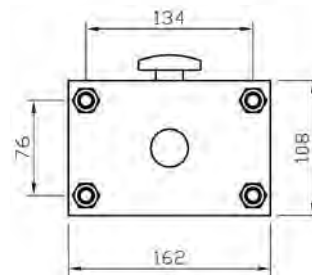
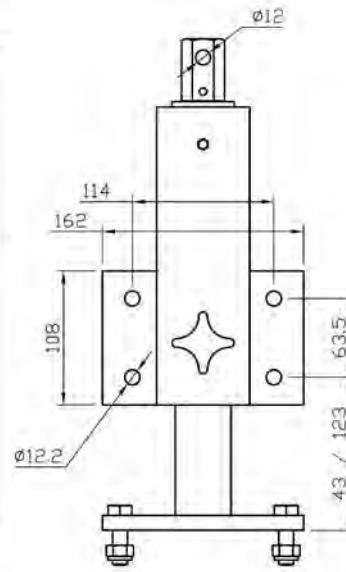
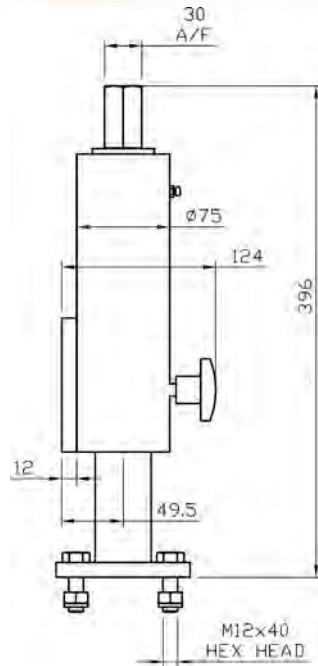

Brauer have developed a range of jacking units expanding further our comprehensive range of heavy duty castors and wheels. The jacking units are highly adaptable across a broad range of environments and applications. Many options are available giving this new product unsurpassed flexibility for the worldwide market place. Availability and delivery is enhanced due to products being totally manufactured within the wheels and castors division based in the UK. Robust design. Load rating up to 1000kg per unit. Integral swivel mechanism incorporated into jacking castor. Designed to suit our GG fixed castor. Wheel options from 100mm to 250mm diameter. Wheel options include steel, polyurethane and nylon. Jacking units now form part of Brauer comprehensive range of wheels and castors.

Approximate weight: 25Kg

FOR TECHNICAL INFORMATION COVERING LOAD FACTORS, ETC., SEE 'DESIGN DATA' INDEX ON PAGE 20

A	B	C	D				
Wheel Diameter	Overall Height	Overall Length	Wheel Width	Max Load Rating	Wheel Bearing Type	PART NUMBER	Approx Weight kg
POLYURETHANE TYRED WHEEL							
100	133	171	40	450	Ball Journal	JGG/H100/40BJ	33
150	184	206	50	900	Ball Journal	JGG/H150/50BJ	34
200	235	241	40	900	Ball Journal	JGG/H200/40BJ	36
250	286	276	45	1000	Ball Journal	JGG/H250/45BJ	41
JACKING UNIT ONLY						JU1000	25

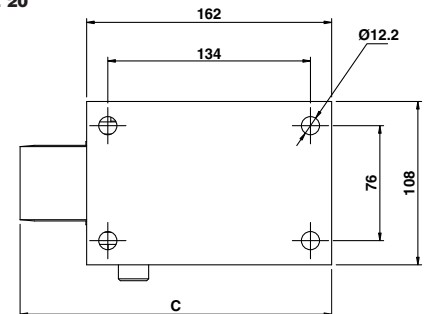

NOTE: Also available with other wheel types.

1000KG JACKING UNIT

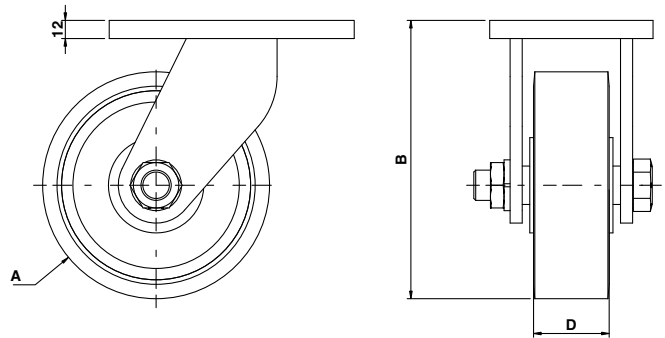
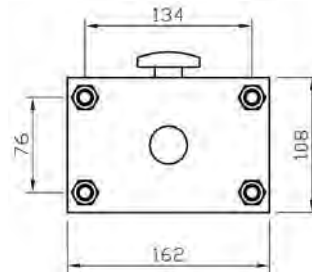
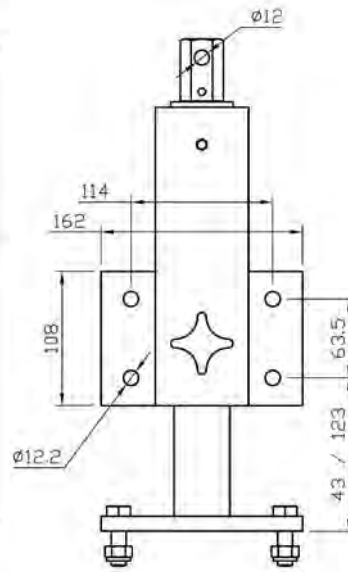
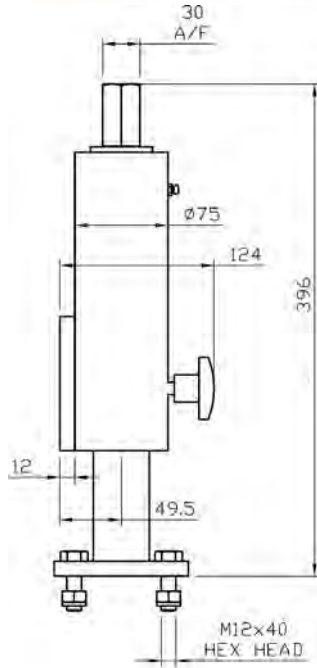

Brauer have developed a range of jacking units expanding further our comprehensive range of heavy duty castors and wheels. The jacking units are highly adaptable across a broad range of environments and applications. Many options are available giving this new product unsurpassed flexibility for the worldwide market place. Availability and delivery is enhanced due to products being totally manufactured within the wheels and castors division based in the UK. Robust design. Load rating up to 1600kg per unit. Integral swivel mechanism incorporated into jacking castor. Designed to suit our MG fixed castor. Wheel options from 150mm to 300mm diameter. Wheel options include steel, polyurethane and nylon. Jacking units now form part of Brauer comprehensive range of wheels and castors.

Approximate weight: 26Kg

FOR TECHNICAL INFORMATION COVERING LOAD FACTORS, ETC., SEE 'DESIGN DATA' INDEX ON PAGE 20

A	B	C	D				
Wheel Diameter	Overall Height	Overall Length	Wheel Width	Max Load Rating	Wheel Bearing Type	PART NUMBER	Approx Weight kg
POLYURETHANE TYRED WHEEL							
150	184	206	50	900	Ball Journal	JMG/H150/50BJ	35
200	235	241	40	900	Ball Journal	JMG/H200/40BJ	37
250	286	276	45	1300	Ball Journal	JMG/H250/45BJ	42
300	337	312	50	1500	Ball Journal	JMG/H300/50BJ	47
JACKING UNIT ONLY						JU1600	26

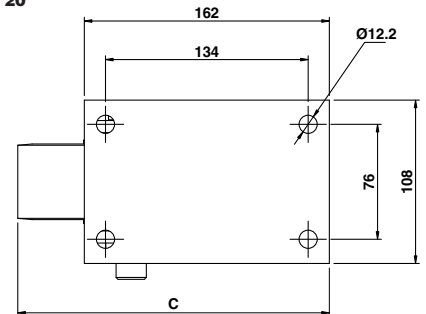

NOTE: Also available with other wheel types.

JWG Series

Load rating 2500kg

BRAUER®

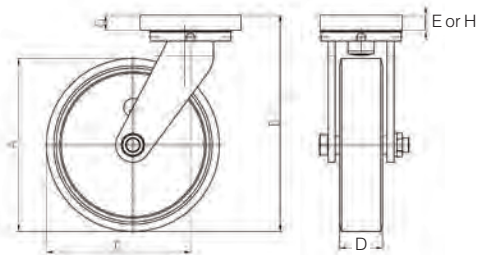
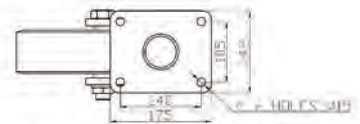
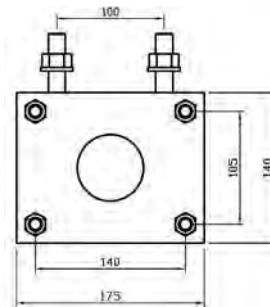
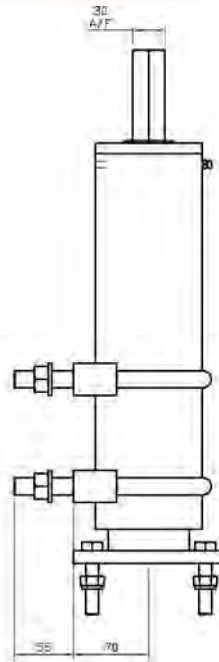
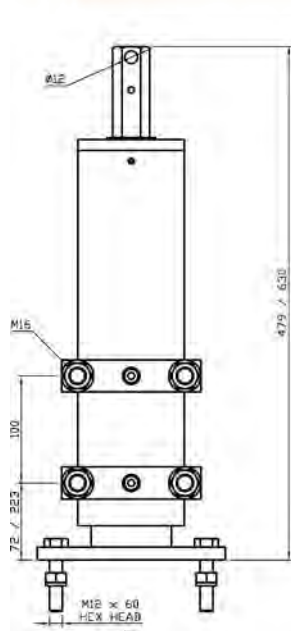

Brauer have developed a Jacking Unit, which is now available for general purchase. The Jacking unit is adaptable to many environments and applications due to our in house design team and manufacturing capability. Many options are available due to the integration of our WG Series Castor into the design, giving unsurpassed flexibility to the market place. Availability and delivery are enhanced because we are a leading UK manufacturer and control all aspects of the Jacking Unit.

Load rating up to 2500kg per unit.

Bespoke design which is now incorporated into our full range of wheels and castors. Robust design. Designed to suit our WG castor range. Wheel options from 150mm to 300mm diameter. Swivel and fixed castor options. Flat foot option for non castor applications. Approximate weight 35Kg.

(E) Swivel top plate thickness 26mm

(H) Fixed top plate thickness 12mm

NOTE: Also available with other wheel types.

FOR TECHNICAL INFORMATION COVERING LOAD FACTORS, ETC., SEE 'DESIGN DATA' INDEX ON PAGE 20

A		B		C		D		▽ Swivel		▽ Fixed	
Wheel Diameter	Overall Height	Swivel Radius	Tread Width	Max Load Rating	Wheel Bearing Type	PART NUMBER	Approx Weight kg	PART NUMBER	Approx Weight kg		
POLYURETHANE TYRED WHEEL											
6"	150	220	125	50	900	Taper Roller	JWGS/H150/50TB	48	JWGF/H150/50TB	48	
8"	200	265	160	75	1750	Taper Roller	JWGS/H200/75TB	59	JWGF/H200/75TB	59	
10"	250	310	200	70	2000	Taper Roller	JWGS/H250/70TB	57	JWGF/H250/70TB	57	
12"	300	375	250	75	2300	Taper Roller	JWGS/H300/75TB	61	JWGF/H300/75TB	61	
JACKING UNIT ONLY									JU2500	35	

2500KG JACKING UNIT

A positive means of stabilising trolley and mobile equipment

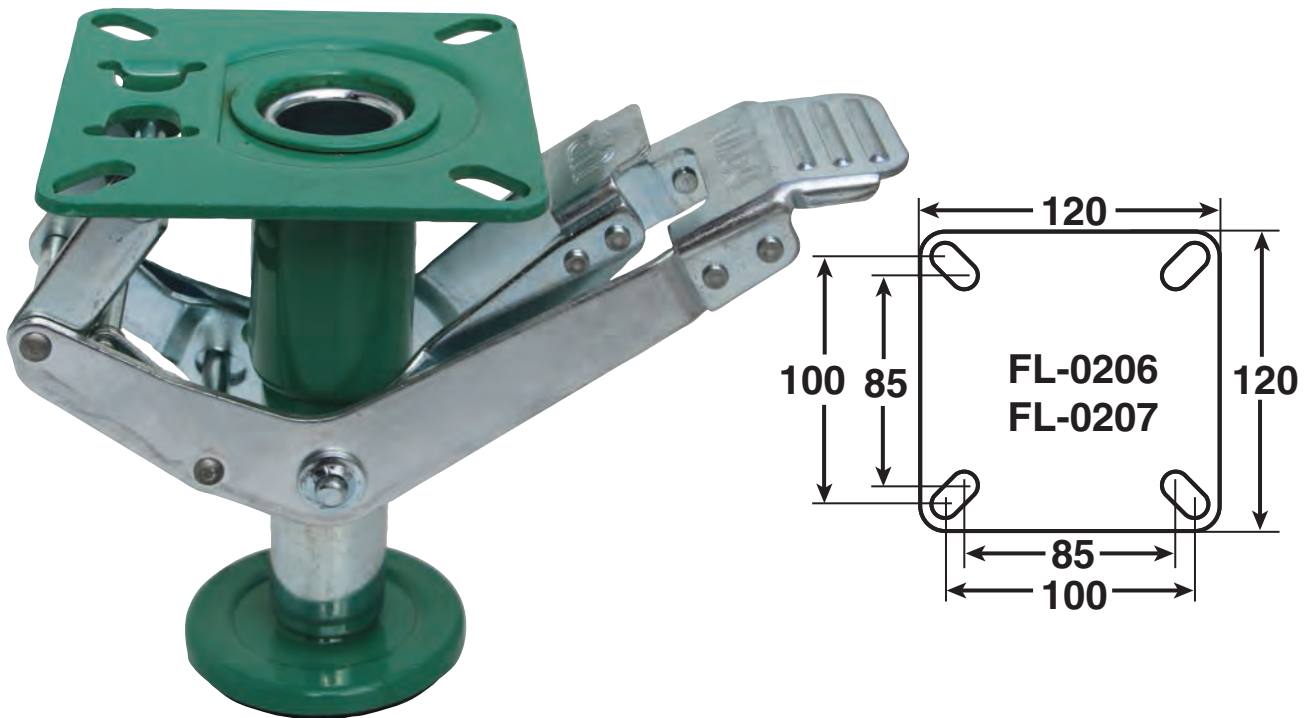

Floor lock top plates have fixing holes to suit 10mm diameter bolts

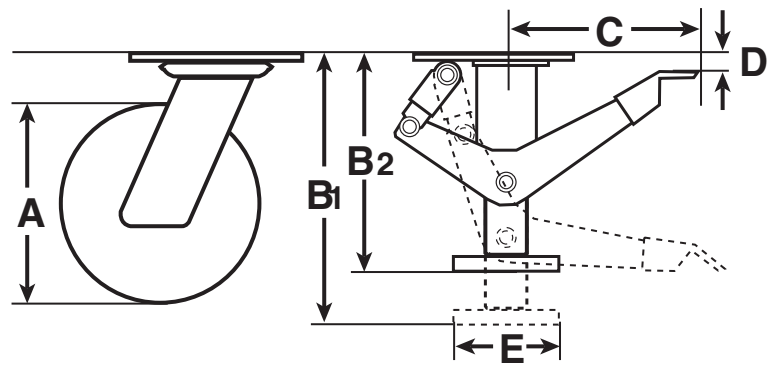

Designed to steady the equipment to which they are fitted and stop horizontal movement, floor locks are never intended to act as a jack. Any attempt to vary the fitting height from the catalogue specification will give failure and/or damage. There is some built-in resilience in the foot pad, which will allow some variations in floor level. Nonetheless it is essential that the floor lock is fitted as closely as possible to one of the swivel castors. Please note that the floor lock can be severely damaged if the linkage is operated whilst the truck is moving.

A	B1	B2	C	D	E	MODEL NUMBER
For Castors With Wheel Diameter	Mounting Height	Retracted Height				
4"	100	150	140	5	80	FL-0206
6"	150	210	145	8	80	FL-0207

OTHER BRAUER CATALOGUES

BRAUER[®]

BRAUER[®]

CLAMPING PRODUCTS

Including Hoist Rings and Lever Handles



www.brauer.co.uk

BRAUER[®]



AIRMOVERS (AIR AMPLIFIERS)



BRAUER[®]



TOOLING COMPONENTS

BRAUER[®]

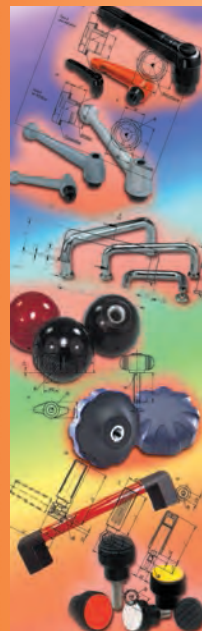

MACHINE ACCESSORIES

www.brauer.co.uk

BRAUER[®]

**OFICJALNY PRZEDSTAWICIEL W
POLSCE : RAIS-TOOLS**

**BUSZEWO 22
62-045 PNIĘWY
POLSKA**

TEL. +48 61 822 90 52

www.rais.pl

TEL. +48 698 684 211

biuro@rais.pl



For further details contact

BRAUER[®]

TEL: 00 44 (0)1908 374022 FAX: 00 44 (0)1908 641628

E-mail: sales@brauer.co.uk Web: www.brauer.co.uk